



**Environmental Engineering (EE);
Power supply interface at the input to
Information and Communication Technology (ICT)
equipment;
Part 1: Alternating Current (AC)**

<https://standards.iteh.ai/catalog/standards/sist/ee8e3a34-5947-4c8a-9194-938e4dd6af16/etsi-en-300-132-1-v2-1-6-2022-08>

Reference

REN/EE-02102

Keywords

environment, interface, power supply

ETSI

650 Route des Lucioles
F-06921 Sophia Antipolis Cedex - FRANCE

Tel.: +33 4 92 94 42 00 Fax: +33 4 93 65 47 16

Siret N° 348 623 562 00017 - APE 7112B
Association à but non lucratif enregistrée à la
Sous-Préfecture de Grasse (06) N° w061004871

Important notice

The present document can be downloaded from:

<http://www.etsi.org/standards-search>

The present document may be made available in electronic versions and/or in print. The content of any electronic and/or print versions of the present document shall not be modified without the prior written authorization of ETSI. In case of any existing or perceived difference in contents between such versions and/or in print, the prevailing version of an ETSI deliverable is the one made publicly available in PDF format at www.etsi.org/deliver.

Users of the present document should be aware that the document may be subject to revision or change of status.

Information on the current status of this and other ETSI documents is available at

<https://portal.etsi.org/TB/ETSIDeliverableStatus.aspx>

If you find errors in the present document, please send your comment to one of the following services:

<https://standards.etsi.org/standards-search> <https://portal.etsi.org/People/CommitteeSupportStaff.aspx> 4c8a-9194-

If you find a security vulnerability in the present document, please report it through our
Coordinated Vulnerability Disclosure Program:

<https://www.etsi.org/standards/coordinated-vulnerability-disclosure>

Notice of disclaimer & limitation of liability

The information provided in the present deliverable is directed solely to professionals who have the appropriate degree of experience to understand and interpret its content in accordance with generally accepted engineering or other professional standard and applicable regulations.

No recommendation as to products and services or vendors is made or should be implied.

In no event shall ETSI be held liable for loss of profits or any other incidental or consequential damages.

Any software contained in this deliverable is provided "AS IS" with no warranties, express or implied, including but not limited to, the warranties of merchantability, fitness for a particular purpose and non-infringement of intellectual property rights and ETSI shall not be held liable in any event for any damages whatsoever (including, without limitation, damages for loss of profits, business interruption, loss of information, or any other pecuniary loss) arising out of or related to the use of or inability to use the software.

Copyright Notification

No part may be reproduced or utilized in any form or by any means, electronic or mechanical, including photocopying and microfilm except as authorized by written permission of ETSI.

The content of the PDF version shall not be modified without the written authorization of ETSI.

The copyright and the foregoing restriction extend to reproduction in all media.

© ETSI 2022.

All rights reserved.

Contents

Intellectual Property Rights	5
Foreword.....	5
Modal verbs terminology.....	6
1 Scope	7
2 References	7
2.1 Normative references	7
2.2 Informative references.....	8
3 Definition of terms, symbols and abbreviations.....	8
3.1 Terms.....	8
3.2 Symbols.....	9
3.3 Abbreviations	10
4 Power Interface "A1"	10
5 AC interface requirements "A1"	12
5.0 Introduction	12
5.1 Nominal voltage at interface "A1"	12
5.2 Normal service voltage range categories at interface "A1"	13
5.3 Reference test voltage at interface "A1".....	13
5.4 Abnormal service voltage ranges at interface "A1".....	14
6 Voltage variations, voltage dips, short interruptions and voltage surges at interface "A1"	14
6.0 Introduction	14
6.1 Voltage variations.....	15
6.2 Voltages dips	16
6.3 Short interruptions	16
6.4 Voltage surges	17
7 AC Supply protection on interface "A1".....	18
8 Maximum steady state current I_m in the normal service voltage range at interface "A1"	18
9 Inrush current on interface "A1"	18
9.1 Limits	18
9.2 Measurement method	19
9.3 Protective device ratings	20
10 Earthing and Bonding.....	20
11 Electrical Safety requirements.....	20
12 EMC requirements at the input of ICT equipment.....	20
Annex A (informative):	ICT power supply configurations providing a unified power interface in the present document
	21
Annex B (normative):	Identification of interface "A1".....
	23
Annex C (informative):	Calculation of the extreme AC voltage range at interface "A1".....
	24
Annex D (informative):	Dimensioning of over-current protective devices.....
	25
Annex E (normative):	Test generator for voltage dips, short interruptions and voltage variations
	26
Annex F (informative):	Details of the voltage surges measurement in the most common case of distribution and protective devices
	27

Annex G (informative):	Guide for measuring inrush current and for transferring the recorded pulses onto the limit chart.....	28
G.1	Measurement.....	28
G.2	Pulse waveform transformation.....	28
History	30

iTeh STANDARD PREVIEW
(standards.iteh.ai)

[ETSI EN 300 132-1 V2.1.6 \(2022-08\)](https://standards.iteh.ai/catalog/standards/sist/ee8e3a34-3947-4c8a-9194-938e4dd6af16/etsi-en-300-132-1-v2-1-6-2022-08)

<https://standards.iteh.ai/catalog/standards/sist/ee8e3a34-3947-4c8a-9194-938e4dd6af16/etsi-en-300-132-1-v2-1-6-2022-08>

Intellectual Property Rights

Essential patents

IPRs essential or potentially essential to normative deliverables may have been declared to ETSI. The declarations pertaining to these essential IPRs, if any, are publicly available for **ETSI members and non-members**, and can be found in ETSI SR 000 314: "*Intellectual Property Rights (IPRs); Essential, or potentially Essential, IPRs notified to ETSI in respect of ETSI standards*", which is available from the ETSI Secretariat. Latest updates are available on the ETSI Web server (<https://ipr.etsi.org/>).

Pursuant to the ETSI Directives including the ETSI IPR Policy, no investigation regarding the essentiality of IPRs, including IPR searches, has been carried out by ETSI. No guarantee can be given as to the existence of other IPRs not referenced in ETSI SR 000 314 (or the updates on the ETSI Web server) which are, or may be, or may become, essential to the present document.

Trademarks

The present document may include trademarks and/or tradenames which are asserted and/or registered by their owners. ETSI claims no ownership of these except for any which are indicated as being the property of ETSI, and conveys no right to use or reproduce any trademark and/or tradename. Mention of those trademarks in the present document does not constitute an endorsement by ETSI of products, services or organizations associated with those trademarks.

DECT™, **PLUGTESTS™**, **UMTS™** and the ETSI logo are trademarks of ETSI registered for the benefit of its Members. **3GPP™** and **LTE™** are trademarks of ETSI registered for the benefit of its Members and of the 3GPP Organizational Partners. **oneM2M™** logo is a trademark of ETSI registered for the benefit of its Members and of the oneM2M Partners. **GSM®** and the GSM logo are trademarks registered and owned by the GSM Association.

Foreword

This draft European Standard (EN) has been produced by ETSI Technical Committee Environmental Engineering (EE), and is now submitted for the combined Public Enquiry and Vote phase of the ETSI standards EN Approval Procedure.

The present document is part 1 of a multi-part deliverable covering Environmental Engineering (EE); Power supply interface at the input to Information and Communication Technology (ICT) equipment, as identified below:

Part 1: "Alternating Current (AC)";

Part 2: "-48 V Direct Current (DC)";

Part 3: "Up to 400 V Direct Current (DC)";

Proposed national transposition dates	
Date of latest announcement of this EN (doa):	3 months after ETSI publication
Date of latest publication of new National Standard or endorsement of this EN (dop/e):	6 months after doa
Date of withdrawal of any conflicting National Standard (dow):	6 months after doa

Modal verbs terminology

In the present document "**shall**", "**shall not**", "**should**", "**should not**", "**may**", "**need not**", "**will**", "**will not**", "**can**" and "**cannot**" are to be interpreted as described in clause 3.2 of the [ETSI Drafting Rules](#) (Verbal forms for the expression of provisions).

"**must**" and "**must not**" are **NOT** allowed in ETSI deliverables except when used in direct citation.

iTeh STANDARD PREVIEW
(standards.iteh.ai)

[ETSI EN 300 132-1 V2.1.6 \(2022-08\)](#)

<https://standards.iteh.ai/catalog/standards/sist/ee8e3a34-3947-4c8a-9194-938e4dd6af16/etsi-en-300-132-1-v2-1-6-2022-08>

1 Scope

The present document contains requirements for the input of the ICT equipment connected to interface "A1".

The voltage at interface "A1" defined in the present document is single phase and three phase AC.

The following voltage range categories are covered:

- Narrow single phase "A1"_{n-1p} and narrow three phase "A1"_{n-3p} AC voltage range defined to comply with nominal European AC voltages defined in IEC 60038 [i.2].
- Wide single phase "A1"_{w-1p} and wide three phase "A1"_{w-3p} AC voltage range for worldwide nominal AC voltages. This wide voltage range is based on the nominal voltages defined in IEC 60038 [i.2].

The present document aims at providing compatibility between the power supply equipment and both the ICT equipment, and the different load units connected to the same interface "A1" (e.g. control/monitoring, cooling system, etc.).

The purpose of the present document is:

- to identify a power supply system with the same characteristics for all ICT equipment defined in the area of application; the area of application may be any location where the interface "A1" is used i.e. telecommunication centres, Radio Base Stations, datacentres and customer premises;
- to facilitate interworking of different (types of) loads;
- to facilitate the standardization of power supply systems for ICT equipment;
- to facilitate the installation, operation and maintenance in the same network of ICT equipment and systems from different origins. General requirements for safety and EMC are out of the scope of the present document series unless specific requirement not defined in existing safety or EMC standards.

The present document concerns the requirements for the interface between Information and Communication Technology (ICT) equipment and its power supply. It includes requirements relating to its stability and measurement. Various other references and detailed measurement and test arrangements are contained in informative annexes.

2 References

2.1 Normative references

References are either specific (identified by date of publication and/or edition number or version number) or non-specific. For specific references, only the cited version applies. For non-specific references, the latest version of the referenced document (including any amendments) applies.

Referenced documents which are not found to be publicly available in the expected location might be found at <https://docbox.etsi.org/Reference/>.

NOTE: While any hyperlinks included in this clause were valid at the time of publication, ETSI cannot guarantee their long term validity.

The following referenced documents are necessary for the application of the present document.

- [1] IEC 60947-2: "Low-voltage switchgear and controlgear - Part 2: Circuit-breakers".
- [2] IEC 60269-1: "Low-voltage fuses - Part 1: General requirements".
- [3] IEC 61000-4-5:2014+AMD1:2017: "Electromagnetic compatibility (EMC) - Part 4-5: Testing and measurement techniques - Surge immunity test".

- [4] IEC 61000-4-11:2020: "Electromagnetic compatibility (EMC) - Part 4-11: Testing and measurement techniques - Voltage dips, short interruptions and voltage variations immunity tests for equipment with input current up to 16 A per phase".

2.2 Informative references

References are either specific (identified by date of publication and/or edition number or version number) or non-specific. For specific references, only the cited version applies. For non-specific references, the latest version of the referenced document (including any amendments) applies.

NOTE: While any hyperlinks included in this clause were valid at the time of publication, ETSI cannot guarantee their long term validity.

The following referenced documents are not necessary for the application of the present document but they assist the user with regard to a particular subject area.

- [i.1] ETSI ETS 300 132-1 (Edition 1): "Equipment Engineering (EE); Power supply interface at the input to telecommunications equipment; Part 1: Operated by alternating current (ac) derived from direct current (dc) sources".
- [i.2] IEC 60038:2009+AMD1:2021: "IEC standard voltages".
- [i.3] IEC 60050-601: "International Electrotechnical Vocabulary (IEV) Part 601: Generation, transmission and distribution of electricity - General".
- [i.4] Void.
- [i.5] Void.
- [i.6] Void.
- [i.7] Void.
- [i.8] IEC 60445: "Basic and safety principle for man-machine interface, marking and identification - Identification of equipment terminals, conductor terminations and conductors".
<http://standards.iteh.ai/catalog/standards/iec/60445-2010>
- [i.9] IEC 60898-1:2015: "Electrical accessories - Circuit-breakers for overcurrent protection for household and similar installations - Part 1: Circuit-breakers for a.c. operation".
- [i.10] IEC 60898-2: "Electrical accessories - Circuit-breakers for overcurrent protection for household and similar installations - Part 2: Circuit-breakers for AC and DC operation".
- [i.11] IEC 60364 series: "Low-voltage electrical installations".
- [i.12] IEC 62040 series: "Uninterruptible power systems (UPS)".
- [i.13] IEC 60050-351:2006: "International Electrotechnical Vocabulary (IEV) - Part 351: Control technology".

3 Definition of terms, symbols and abbreviations

3.1 Terms

For the purposes of the present document, the following terms apply:

abnormal service voltage ranges: steady-state voltage ranges over which the ICT equipment will not be expected to maintain normal service but will survive undamaged

area of application: any location where the interface "A1" is used i.e. telecommunication centres, Radio Base Stations, datacentres and customer premises

customer premises: location which is the sole responsibility of the customer

ICT equipment: device, in the telecommunication network infrastructure, that provides an ICT service

interface A: interface, physical point, at which -48 VDC power supply is connected in order to operate the ICT equipment

interface "A1": interface, physical point, at which AC power supply is connected in order to operate the ICT equipment

NOTE: "A1"_n and "A1"_w are used for different voltage ranges: narrow and wide respectively.

interface A3: interface, physical point, at which 400 VDC power supply is connected in order to operate the ICT equipment

load unit: power consuming equipment, that is part of a system block

nominal voltage: value of the voltage by which the electrical installation or part of the electrical installation is designated and identified

NOTE: This definition is based on IEC 60050-601 [i.3].

normal service: service mode where ICT equipment operates within its specification

normal service voltage range: range of the steady-state voltage at the "A1" interface over which the equipment will maintain normal service

power supply: power supply to which ICT equipment is intended to be connected

reference test voltage: voltage used as a reference to define the test voltage in the present document

NOTE: The test voltage may be also a percentage of this voltage.

system block: functional group of ICT equipment depending for its operation and performance on its connection to the same power supply

steady-state: state of a system at which all state and output variables remain constant in time while all input variables are constant

NOTE: This definition is numbered 351-24-09 in IEC 60050-351:2006 [i.13].

telecommunication centre: any location where ICT equipment is installed and is the sole responsibility of the operator

3.2 Symbols

For the purposes of the present document, the following symbols apply:

"A1" _{n-1p}	Single phase narrow voltage range at interface "A1"
"A1" _{n-3p}	Three phase narrow voltage range at interface "A1"
"A1" _{w-1p}	Single phase wide voltage range at interface "A1"
"A1" _{w-3p}	Three phase wide voltage range at interface "A1"
I_m	Maximum steady state current drain at interface "A1"
I_t	Instantaneous surge current at interface "A1"
I_{UT}	Maximum input current (at AC RMS), stated by the manufacturer, for a fully-equipped and loaded system block behind interface "A1"
U_T	Reference test voltage for narrow voltage range
U_{TW1min}	Minimum reference test voltage for wide voltage range for single phase or 3 phase line to neutral
U_{TW1max}	Maximum reference test voltage for wide voltage range for single phase or 3 phase line to neutral
U_{TW2min}	Minimum reference test voltage for wide voltage range for 3 phase
U_{TW2max}	Maximum reference test voltage for wide voltage range for 3 phase

3.3 Abbreviations

For the purposes of the present document, the following abbreviations apply:

AC	Alternating Current
NOTE:	Also when used as a suffix to units of measurement.
DC	Direct Current
NOTE:	Also when used as a suffix to units of measurement.
EMC	ElectroMagnetic Compatibility
EUT	Equipment Under Test
ICT	Information and Communication Technology
L	Phase conductor
LISN	Line Impedance Stabilization Networks
N	Neutral conductor
PE	Protective Earth
RMS	Root Mean Square
UPS	Uninterruptible Power Supply
VAC	Volts Alternating Current
VDC	Volts Direct Current

4 Power Interface "A1"

The power supply interface, interface "A1" of figure 1, is a physical point to which all the requirements are related. This point is situated between the power supply system(s) and the power consuming ICT equipment of the area of application defined in the scope of the present document.

An example of configurations in which interface "A1" is identified is given in annex B.

Interface "A1" is located at the power terminals of the ICT equipment or system as defined by the manufacturer in accordance to IEC 60445 [i.8].

NOTE 1: Subject to the installation preconditions, this point may be located at any other point between the power supply system and the ICT equipment by mutual agreement of the relevant parties.

NOTE 2: The power supply can be derived from AC grid e.g. through AC bypass of UPS or inverters.

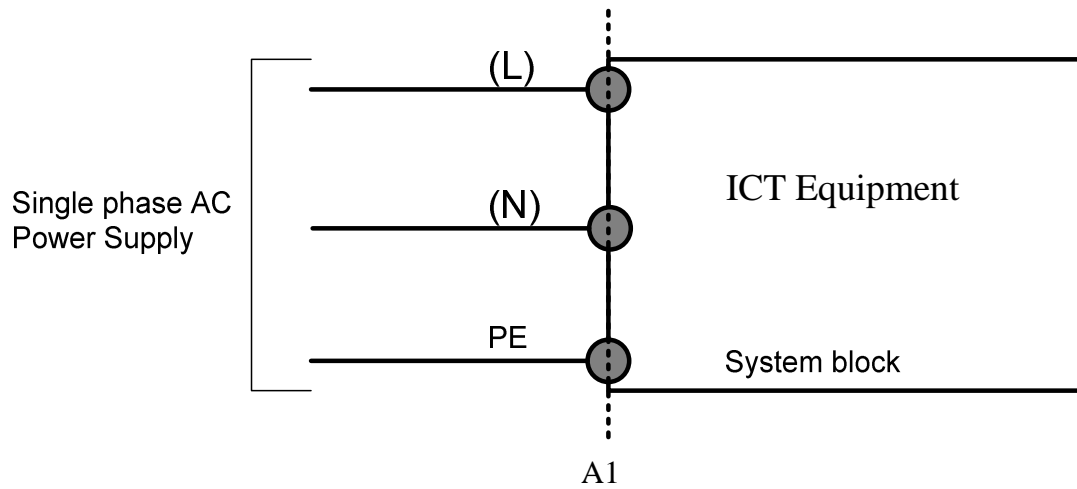

- (L) Live AC terminal in single phase supply.
- (N) Neutral AC terminal.
- PE Protective Earth.

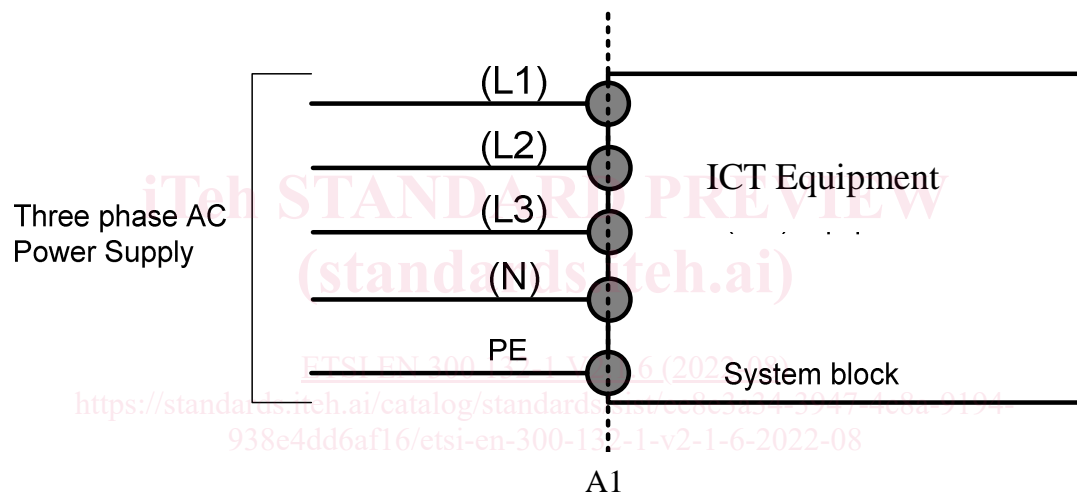

- (L1, L2, L3) Live AC terminals in 3 phases supply.
- (N) Optional Neutral AC terminal.
- PE Protective Earth.

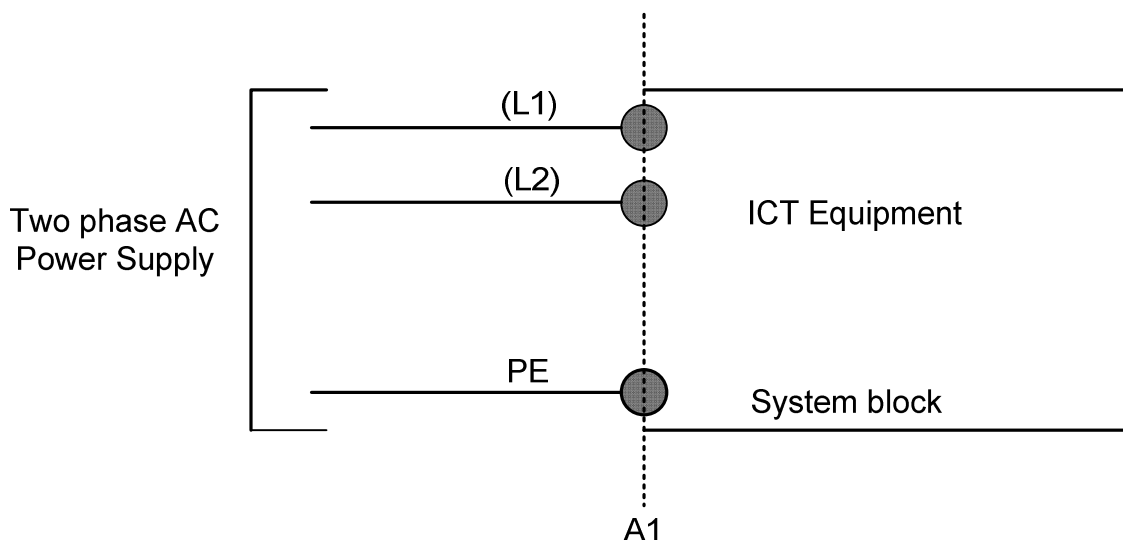

(L1, L2) Live AC terminals in 2 phases supply.
PE Protective Earth.

Figure 1: General identification of the interface "A1" in single, dual and 3 phase AC supply

5 AC interface requirements "A1"

5.0 Introduction (standards.iteh.ai)

The definition of the AC interface voltages ranges and typical operating voltage values are defined in the following subclauses of clause 5.

5.1 Nominal voltage at interface "A1"

In Europe, the AC input voltage of the ICT equipment shall comply with the nominal single phase voltage of 230 V AC and for three phase it shall comply with 400 V AC at a power frequency of 50 Hz.

NOTE 1: Nominal voltage as defined in table 1 of IEC 60038 [i.2].

ICT equipment intended for worldwide use is recommended to comply with nominal voltages and frequencies defined in table 1 of the present document.

NOTE 2: Nominal voltages as defined in table 1 of the present document and table 6 of IEC 60038 [i.2], except for 115 V and 127 V AC single phase which is also used in some countries.

Table 1: Nominal voltages

AC Single phase voltages (50 Hz or 60 Hz)	AC Three phase voltages (50 Hz or 60 Hz)
100, 110, 115, 120, 127, 200, 220, 230, 240	200, 208, 220, 240, 380, 400, 415