**Touring ski-boots for adults —
Interface with touring ski-bindings —
Requirements and test methods**

*Chaussures de ski de randonnée pour adultes — Zone de contact avec
les fixations de skis de randonnée — Exigences et méthodes d'essai*

iTeh STANDARD PREVIEW
(standards.iteh.ai)

[ISO 9523:2015](https://standards.iteh.ai/catalog/standards/sist/ee41ef11-9b68-4246-9687-a3e401017603/iso-9523-2015)

[https://standards.iteh.ai/catalog/standards/sist/ee41ef11-9b68-4246-9687-
a3e401017603/iso-9523-2015](https://standards.iteh.ai/catalog/standards/sist/ee41ef11-9b68-4246-9687-a3e401017603/iso-9523-2015)



iTeh STANDARD PREVIEW
(standards.iteh.ai)

ISO 9523:2015

<https://standards.iteh.ai/catalog/standards/sist/ee41ef11-9b68-4246-9687-a3e401017603/iso-9523-2015>



COPYRIGHT PROTECTED DOCUMENT

© ISO 2015, Published in Switzerland

All rights reserved. Unless otherwise specified, no part of this publication may be reproduced or utilized otherwise in any form or by any means, electronic or mechanical, including photocopying, or posting on the internet or an intranet, without prior written permission. Permission can be requested from either ISO at the address below or ISO's member body in the country of the requester.

ISO copyright office
Ch. de Blandonnet 8 • CP 401
CH-1214 Vernier, Geneva, Switzerland
Tel. +41 22 749 01 11
Fax +41 22 749 09 47
copyright@iso.org
www.iso.org

Contents

	Page
Foreword	iv
1 Scope	1
2 Normative references	1
3 Terms and definitions	1
4 Requirements and test methods	2
4.1 General	2
4.2 Dimensions	2
4.3 Design	4
4.3.1 Sole length	4
4.3.2 Boot sole interface	4
4.3.3 Side walls at boot toe	4
4.3.4 Side walls at boot heel	4
4.3.5 Rigidity	5
4.3.6 Boot sole interface areas with the binding	6
4.3.7 Free spaces	9
4.3.8 Toe and heel boot/binding interface areas	14
4.3.9 Bevelled areas	16
4.3.10 Bearing surface at heel	16
4.3.11 Bearing surface at toe	17
4.3.12 Style of boot shell	17
4.3.13 Mounting point	17
5 Marking	17
6 Instructions for use	17
Annex A (informative) Mondopoint system ski-boot sizing and marking	18
Annex B (informative) Dimensions and requirements of "second degree"	19
Bibliography	20

Foreword

ISO (the International Organization for Standardization) is a worldwide federation of national standards bodies (ISO member bodies). The work of preparing International Standards is normally carried out through ISO technical committees. Each member body interested in a subject for which a technical committee has been established has the right to be represented on that committee. International organizations, governmental and non-governmental, in liaison with ISO, also take part in the work. ISO collaborates closely with the International Electrotechnical Commission (IEC) on all matters of electrotechnical standardization.

The procedures used to develop this document and those intended for its further maintenance are described in the ISO/IEC Directives, Part 1. In particular the different approval criteria needed for the different types of ISO documents should be noted. This document was drafted in accordance with the editorial rules of the ISO/IEC Directives, Part 2 (see www.iso.org/directives).

Attention is drawn to the possibility that some of the elements of this document may be the subject of patent rights. ISO shall not be held responsible for identifying any or all such patent rights. Details of any patent rights identified during the development of the document will be in the Introduction and/or on the ISO list of patent declarations received (see www.iso.org/patents).

Any trade name used in this document is information given for the convenience of users and does not constitute an endorsement.

For an explanation on the meaning of ISO specific terms and expressions related to conformity assessment, as well as information about ISO's adherence to the WTO principles in the Technical Barriers to Trade (TBT) see the following URL: [Foreword - Supplementary information](#).

The committee responsible for this document ISO/TC 83, *Sports and other recreational facilities and equipment*, Subcommittee SC 4, *Snowsports Equipment*.

This third edition cancels and replaces the second edition (ISO 9523:2008), which has been technically revised.

Touring ski-boots for adults — Interface with touring ski-bindings — Requirements and test methods

1 Scope

This International Standard specifies the dimensions and characteristics of the interface, requirements, test methods, and marking of ski-boots with a rigid sole (see 3.5) which are used with current systems of touring ski-bindings with attachment at the boot toe and boot heel, the proper release function of which depends on the dimensions and design of the interfaces.

For ski-binding systems that function irrespective of the sole shape or that have different requirements for the sole dimensions, it is not always necessary for the ski-boot soles to comply with this International Standard in order to achieve the desired degree of safety.

This International Standard is applicable to ski-boots of sizes 15,0 and larger in the Mondopoint system (see Annex A).

It is applicable to rigid touring boots. Boots with softer shells like Telemark boots are excluded as they do not have the necessary shell stability to act as part of the release systems.

2 Normative references

The following documents, in whole or in part, are normatively referenced in this document and are indispensable for its application. For dated references, only the edition cited applies. For undated references, the latest edition of the referenced document (including any amendments) applies.

ISO 527-1, *Plastics — Determination of tensile properties — Part 1: General principles*

ISO 527-2, *Plastics — Determination of tensile properties — Part 2: Test conditions for moulding and extrusion plastics*

ISO 554, *Standard atmospheres for conditioning and/or testing — Specifications*

ISO 868, *Plastics and ebonite — Determination of indentation hardness by means of a durometer (Shore hardness)*

ISO 1183 (all parts), *Plastics — Methods for determining the density of non-cellular plastics*

ISO 2039-1, *Plastics — Determination of hardness — Part 1: Ball indentation method*

ISO 5355, *Alpine ski-boots — Requirements and test methods*

ISO 9407, *Shoe sizes — Mondopoint system of sizing and marking*

3 Terms and definitions

For the purposes of this document, the terms and definitions given in ISO 5355 and the following apply.

3.1

interface area

part of the ski-boot intended for contact with the ski-binding

3.2

toe interface area

part of the ski-boot intended to fit with the front binding

3.3

heel interface area

part of the ski-boot intended to fit with the rear binding

3.4

free space

space intended to avoid contact between ski-boots and binding, especially during step in/step out or release

3.5

rigid ski boot sole

ski boot sole which does not flex when walking

Note 1 to entry: See [4.3.5.1](#).

3.6

median plane

middle plane of the sole, longitudinal and perpendicular to the bearing surface

3.7

bearing surface

toe or heel surface of the boot sole which is in contact with a plane on which the boot is standing

3.8

ski-brake

device to stop the ski after release of the binding

ITEH STANDARD PREVIEW
(standards.iteh.ai)

4 Requirements and test methods

4.1 General

ISO 9523:2015

<https://standards.iteh.ai/catalog/standards/sist/ee41ef11-9b68-4246-9687->

<a3401017603/iso-9523-2015>

If no specific test methods are indicated, check the characteristics as appropriate (e.g. by measurement).

If not otherwise indicated, execute the testing under standard atmosphere 23/50, in accordance with ISO 554, with ordinary tolerances.

4.2 Dimensions

The dimensions of the boot toe and heel shall correspond to [Figure 1](#). Other boot dimensions need not correspond to [Figure 1](#).

Fundamentally, all dimensions shall be within the indicated tolerance. However, relevance to safety varies in importance depending on the indicated dimensions.

Looking at several dimensions (see [Annex B](#)), a deviation from the tolerances may be accepted, provided that the following requirements are respected:

- a) deviations remain exceptional;
- b) deviations are small;
- c) no limitations of function arise with all marketable and critical bindings;
- d) tolerance is respected at the next possible chance (e.g. reconstruction of a tool).

The gauge (see [Figure 1](#)) shall be wider than the boot sole.

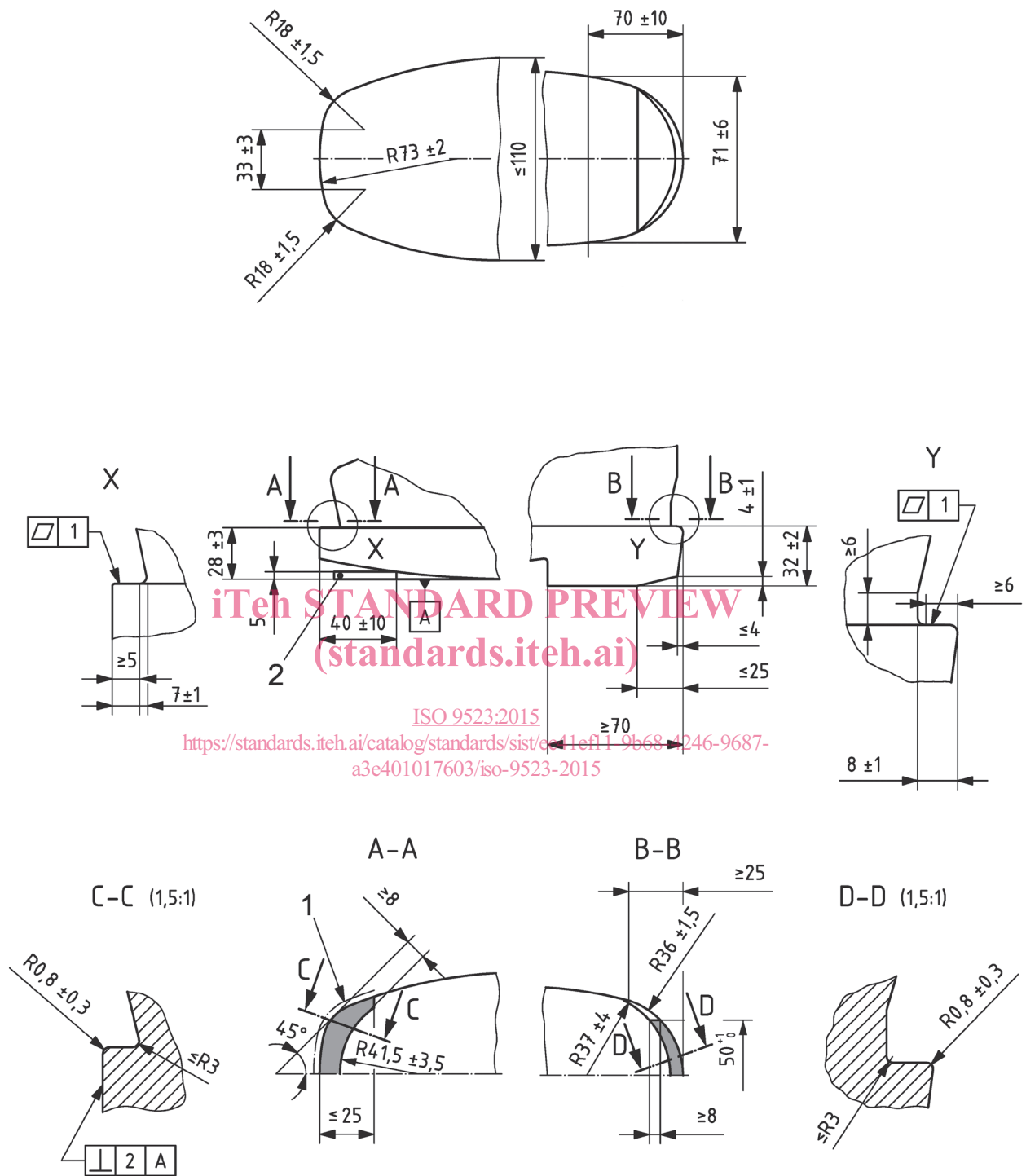

Key

- 1 area where perpendicularity tolerance is valid
- 2 gauge

NOTE Shaded areas are those in which the tolerance of evenness and the dimensions 28 mm ± 3 mm and 32 mm ± 2 mm are valid.

Figure 1 — Dimensions of boot toe and heel

4.3 Design

4.3.1 Sole length

The sole lengths of the two ski-boots in a pair shall not differ by more than 2 mm.

4.3.2 Boot sole interface

The sole dimensions in the toe and heel boot binding interface areas shall be symmetrical about the median plane within an admissible deviation of 1 mm.

There shall be no protrusion of the sole beyond the shell for the whole perimeter of the whole boot sole interface areas.

4.3.3 Side walls at boot toe

The side walls of the sole at the boot toe up to a distance of at least 25 mm from the toe end shall be perpendicular to the bearing surface within an admissible inward-outward deviation as shown in [Figure 1](#), section C-C.

If the side walls of the sole are built in two parts, it shall be ensured that no part of the lower area of the sole protrudes beyond the upper profile.

4.3.4 Side walls at boot heel

The lateral side walls of the sole at the boot heel up to a distance of at least 70 mm from the heel end shall be perpendicular to the bearing surface or tapered inwards-outwards between 0° and 10° up to a height of 14 mm.

If lateral grooves of more than 2 mm depth are present at the heel (see [Figure 2](#)), supports at least complying with [Figure 3](#) shall remain.

Other configurations of grooves are allowed if they have no influence on the mechanism and function of the boot/binding system.

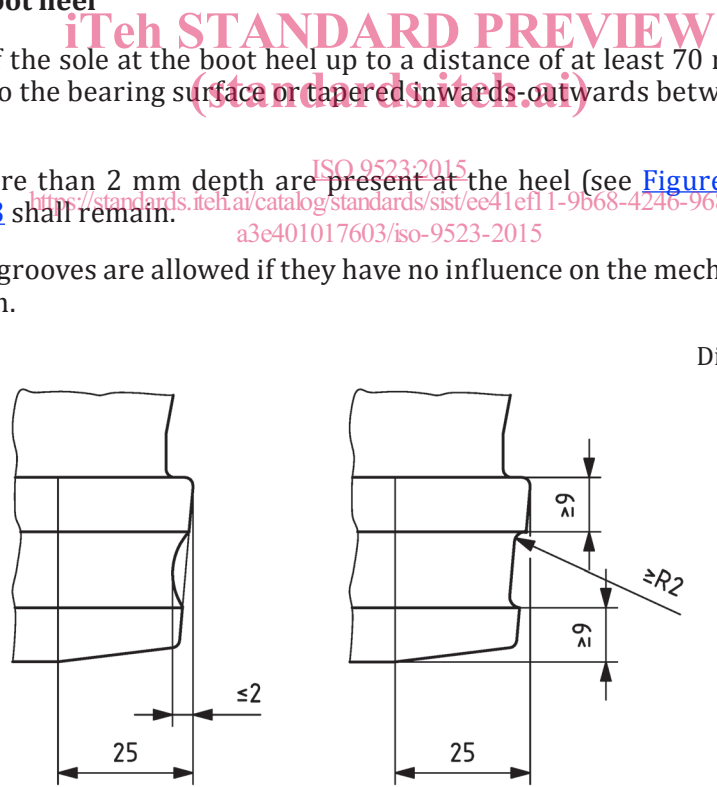

Dimensions in millimetres

Figure 2 — Lateral grooves at heel

Dimensions in millimetres

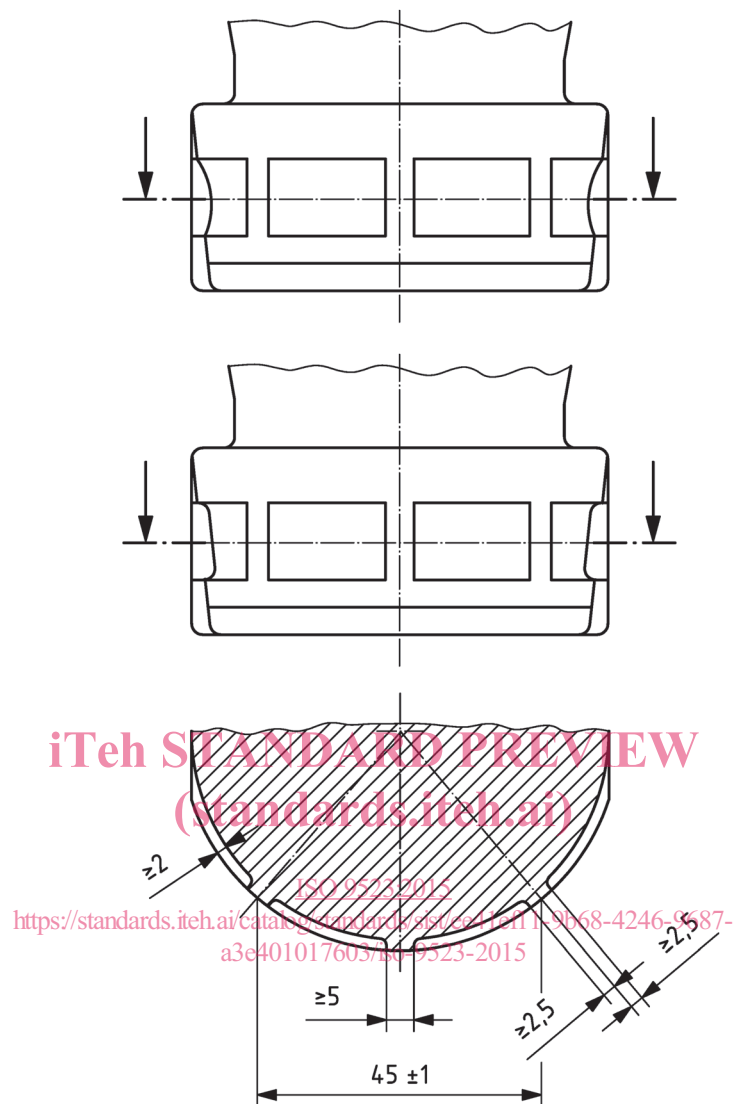

Figure 3 — Lateral supports at heel

4.3.5 Rigidity

4.3.5.1 Requirements

When measured in accordance with 4.3.5.2, the sole shall not deflect more than 5 mm.

NOTE This is to avoid any contact point outside the frontal zone and the boot sole interface area (see Figure 5) in order to ensure proper lateral release function.

4.3.5.2 Test method

The rigid metal test bar (width 25 mm) shall cover the whole width of the sole (see Figure 4).

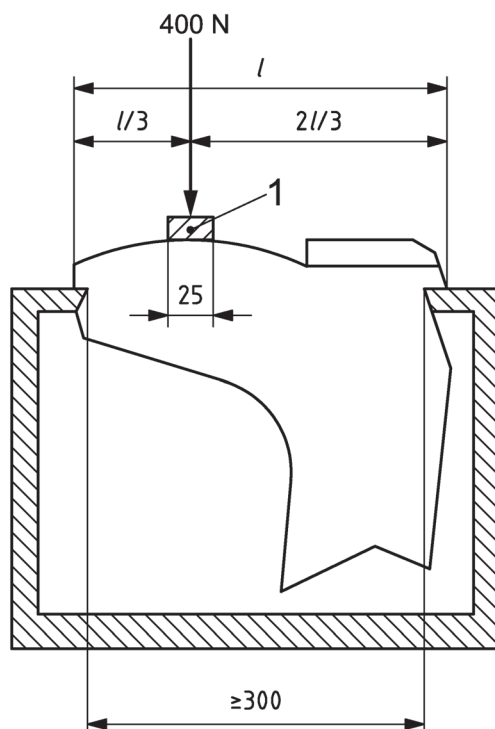

iTeh STANDARD PREVIEW
(standards.iteh.ai)

Key

1 rigid metal test bar

ISO 9523:2015
Figure 4 — Testing of rigidity
<https://standards.iteh.ai/catalog/standards/sist/ce41e811-9b68-4246-9687-a3e401017603/iso-9523-2015>

4.3.6 Boot sole interface areas with the binding

The boot sole interface areas shall conform to [Figure 5](#).

There shall be no gaps >10 mm between two studs in any direction in the toe interface area and heel interface area (see [Figure 5](#)).

Dimensions in millimetres

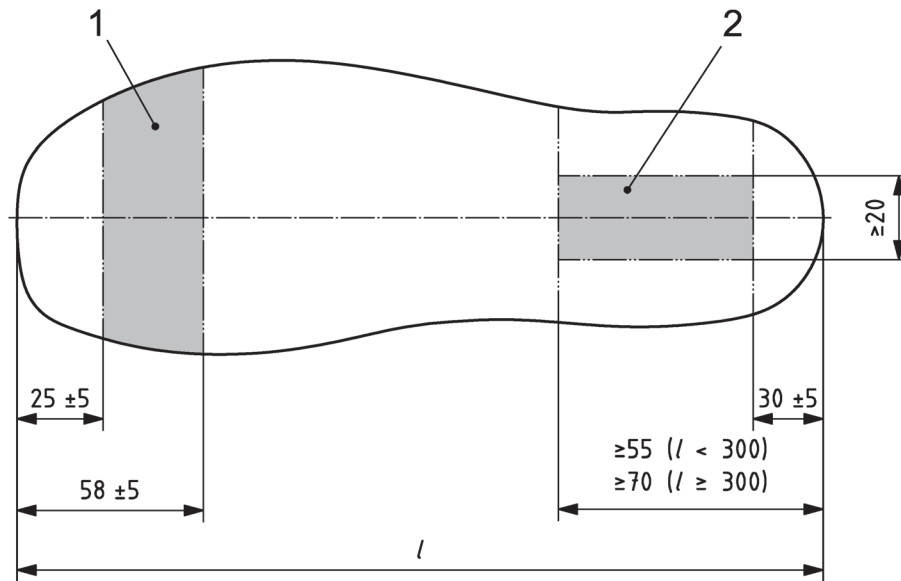

Key

- 1 toe interface area
- 2 heel interface area
- l* length of sole

iTeh STANDARD PREVIEW
(standards.iteh.ai)

Figure 5 — Interface areas

ISO 9523:2015

<https://standards.iteh.ai/catalog/standards/sist/ee41ef11-9b68-4246-9687-a5c401017605/iso-9523-2015>
Table 1 — Boot sole interface area with the binding

Interface area	Percentage of the area in contact with the bearing surface of the binding
toe	>25
heel	>40

The rubber material for the interface areas shall have Shore A hardness of at least 65 and coefficient of dynamic friction of <0,2.

Testing of Shore A hardness shall be in accordance with ISO 868.

Testing of the coefficient of dynamic friction shall be in accordance with [4.3.6.1](#).

4.3.6.1 Test method

4.3.6.1.1 Principle

The coefficient of dynamic friction is determined by the ratio of the force F1, necessary to move a low-friction element over the two interface areas of the boot, to the test load F2, which is applied to the low-friction element.

4.3.6.1.2 Test equipment and conditions

The following test equipment and conditions shall be required.

- a) Six sample boots of at least three different sizes, stored for at least 14 d with the last 12 h of storage before the test under standard atmosphere.