Aeronavtika - Vijaki, valjasta glava, spiralna vdolbina, z navojem do glave, iz toplotno in korozijsko odpornega jekla, pasivirani - Klasifikacija: 1100 MPa (pri temperaturi okolice)/425 °C

Aerospace series - Screws, pan head, Spiral Drive Recess, threaded to head, in heat and corrosion resisting steel, passivated - Classification : 1 100 MPa (at ambient temperature) / 425 °C

Luft- und Raumfahrt - Flachkopfschraube mit Spiral-Antrieb, Gewinde annähernd bis Kopf, aus korrosionsbeständigem und hochwarmfestem Stahl, passiviert - Klasse: 1 100 MPa (bei Raumtemperatur)/425 °C

Série aérospatiale - Vis à tête cylindrique, empreinte en spirale, fileté jusqu'à proximité de la tête, en acier résistant à chaud et à la corrosion, passivée - Classification : 1 100 MPa (à température ambiante)/425 °C

Ta slovenski standard je istoveten z: EN 4846:2022

ICS:

49.025.10	Jekla	Steels
49.030.20	Sorniki, vijaki, stebelni vijaki	Bolts, screws, studs

SIST EN 4846:2022**en,fr,de**

**iTeh STANDARD
PREVIEW
(standards.iteh.ai)**

[SIST EN 4846:2022](#)

<https://standards.iteh.ai/catalog/standards/sist/1e334c85-c181-4495-8913-7309fcb44551/sist-en-4846-2022>

EUROPEAN STANDARD

EN 4846

NORME EUROPÉENNE

EUROPÄISCHE NORM

March 2022

ICS 49.030.20

English Version

**Aerospace series - Screws, pan head, Spiral Drive Recess,
threaded to head, in heat and corrosion resisting steel,
passivated - Classification : 1 100 MPa (at ambient
temperature) / 425 °C**

Série aérospatiale - Vis à tête cylindrique, empreinte en spirale, fileté jusqu'à proximité de la tête, en acier résistant à chaud et à la corrosion, passivée - Classification : 1 100 MPa (à température ambiante)/425 °C

Luft- und Raumfahrt - Flachkopfschraube mit Spiral-Antrieb, Gewinde annähernd bis Kopf, aus korrosionsbeständigem und hochwarmfestem Stahl, passiviert - Klasse: 1 100 MPa (bei Raumtemperatur)/425 °C

This European Standard was approved by CEN on 10 January 2022.

CEN members are bound to comply with the CEN/CENELEC Internal Regulations which stipulate the conditions for giving this European Standard the status of a national standard without any alteration. Up-to-date lists and bibliographical references concerning such national standards may be obtained on application to the CEN-CENELEC Management Centre or to any CEN member.

This European Standard exists in three official versions (English, French, German). A version in any other language made by translation under the responsibility of a CEN member into its own language and notified to the CEN-CENELEC Management Centre has the same status as the official versions.

CEN members are the national standards bodies of Austria, Belgium, Bulgaria, Croatia, Cyprus, Czech Republic, Denmark, Estonia, Finland, France, Germany, Greece, Hungary, Iceland, Ireland, Italy, Latvia, Lithuania, Luxembourg, Malta, Netherlands, Norway, Poland, Portugal, Republic of North Macedonia, Romania, Serbia, Slovakia, Slovenia, Spain, Sweden, Switzerland, Turkey and United Kingdom.



EUROPEAN COMMITTEE FOR STANDARDIZATION
COMITÉ EUROPÉEN DE NORMALISATION
EUROPÄISCHES KOMITEE FÜR NORMUNG

CEN-CENELEC Management Centre: Rue de la Science 23, B-1040 Brussels

Contents		Page
European foreword		3
Introduction		4
1	Scope	5
2	Normative references	5
3	Terms and definitions	5
4	Requirements	5
4.1	Configuration — Dimensions — Masses	5
4.2	Tolerances of form and position	8
4.3	Materials	8
4.4	Surface treatment	8
5	Designation	8
6	Marking	8
7	Technical specification	9
Bibliography		10

iTeh STANDARD
PREVIEW
(standards.iteh.ai)

[SIST EN 4846:2022
https://standards.iteh.ai/catalog/standards/sist/1e334c85-
c181-4495-8913-7309fcb44551/sist-en-4846-2022](https://standards.iteh.ai/catalog/standards/sist/1e334c85-c181-4495-8913-7309fcb44551/sist-en-4846-2022)

European foreword

This document (EN 4846:2022) has been prepared by the Aerospace and Defence Industries Association of Europe — Standardization (ASD-STAN).

After enquiries and votes carried out in accordance with the rules of this Association, this Standard has received the approval of the National Associations and the Official Services of the member countries of ASD, prior to its presentation to CEN.

This European Standard shall be given the status of a national standard, either by publication of an identical text or by endorsement, at the latest by September 2022, and conflicting national standards shall be withdrawn at the latest by September 2022.

Attention is drawn to the possibility that some of the elements of this document may be the subject of patent rights. CEN shall not be held responsible for identifying any or all such patent rights.

According to the CEN-CENELEC Internal Regulations, the national standards organizations of the following countries are bound to implement this European Standard: Austria, Belgium, Bulgaria, Croatia, Cyprus, Czech Republic, Denmark, Estonia, Finland, Former Yugoslav Republic of Macedonia, France, Germany, Greece, Hungary, Iceland, Ireland, Italy, Latvia, Lithuania, Luxembourg, Malta, Netherlands, Norway, Poland, Portugal, Romania, Serbia, Slovakia, Slovenia, Spain, Sweden, Switzerland, Turkey and the United Kingdom.

ITEH STANDARD
PREVIEW
(standards.iteh.ai)

[SIST EN 4846:2022](https://standards.iteh.ai/catalog/standards/sist/1e334c85-c181-4495-8913-7309fcb44551/sist-en-4846-2022)

<https://standards.iteh.ai/catalog/standards/sist/1e334c85-c181-4495-8913-7309fcb44551/sist-en-4846-2022>

EN 4846:2022 (E)

Introduction

Aerospace and Defence Standardisation (ASD-STAN) draws attention to the fact that it is claimed that compliance with this document may involve the use of a patent “Spiral Drive System for Threaded Fasteners” EP1025370B1.

ASD-STAN takes no position concerning the evidence, validity and scope of this patent right.

The holder of this patent right has assured ASD-STAN that he/she is willing to negotiate licences under reasonable and non-discriminatory terms and conditions with applicants throughout the world. In this respect, the statement of the holder of this patent right is registered with ASD-STAN. Information may be obtained from:

Phillips Screw Company
301 Edgewater Drive, Suite 320
Wakefield, Massachusetts 01880
USA

Attention is drawn to the possibility that some of the elements of this document may be the subject of patent rights other than those identified above. ASD-STAN shall not be held responsible for identifying any or all such patent rights.

**iTeh STANDARD
PREVIEW
(standards.iteh.ai)**

[SIST EN 4846:2022](https://standards.iteh.ai/catalog/standards/sist/1e334c85-c181-4495-8913-7309fcb44551/sist-en-4846-2022)
<https://standards.iteh.ai/catalog/standards/sist/1e334c85-c181-4495-8913-7309fcb44551/sist-en-4846-2022>

1 Scope

This document specifies the characteristics of externally threaded fasteners, pan head, Spiral Drive Recess, threaded to head, in heat and corrosion resisting steel, passivated, for aerospace applications.

Classification: 1 100 MPa¹/425 °C².

2 Normative references

The following documents are referred to in the text in such a way that some or all of their content constitutes requirements of this document. For dated references, only the edition cited applies. For undated references, the latest edition of the referenced document (including any amendments) applies.

EN 2424, *Aerospace series — Marking of aerospace products*

EN 2516, *Aerospace series — Passivation of corrosion resisting steels and decontamination of nickel base alloys*

EN 3761, *Aerospace series — Heat resisting alloy FE-PA2601 — Softened and cold worked — Bar for forged fasteners — $D \leq 50 \text{ mm}$ — $1\ 100 \text{ MPa} \leq R_m \leq 1\ 300 \text{ MPa}$*

EN 4609, *Aerospace series — Spiral drive recesses for threaded fasteners — Geometrical definition and technical requirements*

ISO 3353-1, *Aerospace — Lead and runout threads — Part 1: Rolled external threads*

ISO 5855-2, *Aerospace — MJ threads — Part 2: Limit dimensions for bolts and nuts*

ISO 7913, *Aerospace — Bolts and screws, metric — Tolerances of form and position*

ISO 8168, *Aerospace — Bolts, with MJ threads, made of heat and corrosion resisting steel, strength class 1 100 MPa — Procurement specification*

3 Terms and definitions

No terms and definitions are listed in this document.

ISO and IEC maintain terminological databases for use in standardization at the following addresses:

- ISO Online browsing platform: available at <https://www.iso.org/obp>
- IEC Electropedia: available at <https://www.electropedia.org/>

4 Requirements

4.1 Configuration — Dimensions — Masses

See Figure 1 and Table 1.

Dimensions and tolerances are expressed in millimetres and apply after surface treatment.

¹ Minimum tensile strength of the material at ambient temperature.

² Maximum temperature that the externally threaded fastener can withstand without continuous change in its original characteristics, after return to ambient temperature. The maximum temperature is determined by the material.

EN 4846:2022 (E)

Roughness shall be as follows:

- bearing surfaces (underhead face, fillet radius, thread): $R_{\text{amax}} = 0,8 \mu\text{m}$;
- all other surfaces: $R_{\text{amax}} = 3,2 \mu\text{m}$;
- break sharp edges 0,1 to 0,4.

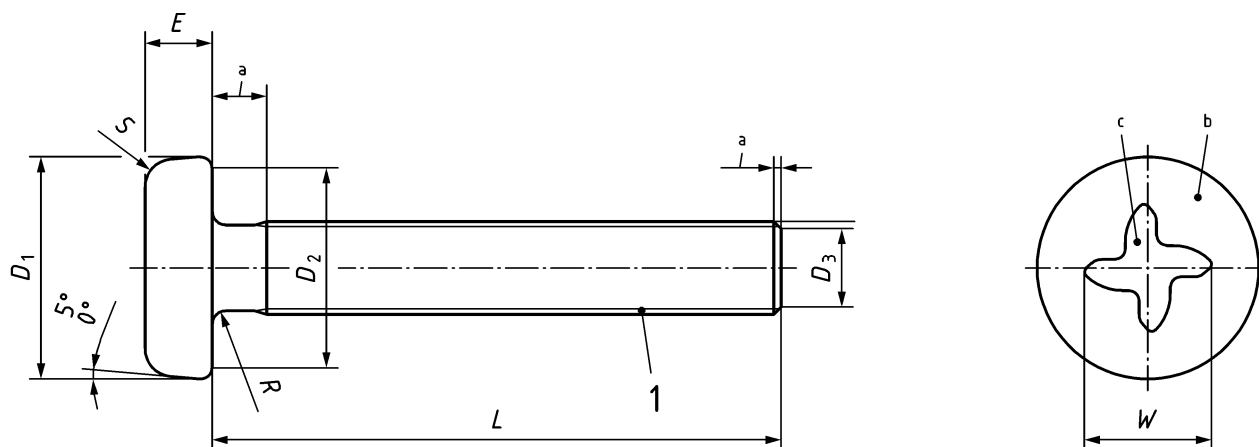

Key

- 1 Thread
 a According to ISO 3353-1.
 b Marking
 c MORTORQ® Spiral Drive Recess³

iTeh STANDARD
 PREVIEW
 (standards.iteh.ai)

NOTE Dimensions not specified are at the manufacturer's option provided that the qualification and acceptance requirements of EN 4609 and technical specification are met.

<https://standards.iteh.ai/catalog/standards/sist/1e334c85-c181-4495-8915-73091c644551/sist-en-4846-2022>
 Figure 1 — Externally threaded fastener, pan head

³ MORTORQ® is the trade name of a product supplied by licensees of the Phillips Screw Company. This information is given for the convenience of users of this document and does not constitute an endorsement by ASD-STAN nor CEN of the product named. Equivalent products may be used if they can be shown to lead to the same results.

Table 1 — Dimensions and masses

Diameter code	Thread ^a	D_1	D_2 min.	D_3		E		$L + 0,3^{b,c}$		Recess Code	W ref	Gauge Penetration		R		S		Mass ^d	
				nom.	Tol.	nom.	Tol.	Code	nom.			max.	min.	nom.	Tol.	max.	min.	e	f
030	MJ3 × 0,5 4h6h	6	4,7	2,3	0 -0,5	1,8	0 -0,2	004 to 042	4 to 42	00	3,07	0,69	0,48	0,4	0	1,2	0,3	0,31	0,05
040	MJ4 × 0,7 4h6h	8	6,7	3,0		2,4		006 to 056	6 to 56	0	4,33	0,99	0,79			1,6	0,4	0,80	0,08
050	MJ5 × 0,8 4h6h	10	8,7	3,4	±0,5	3,0	0 -0,3	008 to 070	8 to 70	1	6,11	1,04	0,81	0 -0,2	2,0	0,5	1,58	0,14	
060	MJ6 × 1 4h6h	12	10,7	4,2		3,6		010 to 084	10 to 84	1	6,11	1,45	1,22		2,4	0,6	2,50	0,20	
070	MJ7 × 1 4h6h	14	12,7	5,2		4,2		010 to 098	10 to 98	2	7,82	1,27	1,04		0,7	2,8	0,7	4,59	0,31
080	MJ8 × 1 4h6h	16	14,7	6,2		4,8		010 to 112	10 to 112	2	7,82	2,03	1,80		3,2	0,8	5,95	0,44	
100	MJ10 × 1,25 4h6h	20	18,7	7,9		6,0		014 to 140	14 to 140	3	8,98	2,21	1,98		0,8	4,0	1,0	10,58	0,59
120	MJ12 × 1,25 4h6h	24	22,7	9,8		7,2		016 to 168	16 to 168	5	12,86	2,31	1,93		0,9	0 -0,3	4,8	1,2	22,54

^a In accordance with ISO 5855-2.

^b Increments:
2 for $L \leq 100$;
4 for $L > 100$.

^c If greater lengths are required, they shall be chosen using the above increments. The length code corresponds to the length L , completed by one or two zeros to the left, where necessary, to obtain a three digit code.

^d Approximate values (kg/1 000 pieces), calculated on the basis of 7,85 kg/dm³, given for information purposes only.

^e Value for first L .

^f Increase for each additional 2 mm of L .

EN 4846:2022 (E)

4.2 Tolerances of form and position

Tolerances of form and position shall be according to ISO 7913.

4.3 Materials

Materials shall be according to EN 3761.

4.4 Surface treatment

Surface treatment shall be according to EN 2516.

5 Designation

EXAMPLE

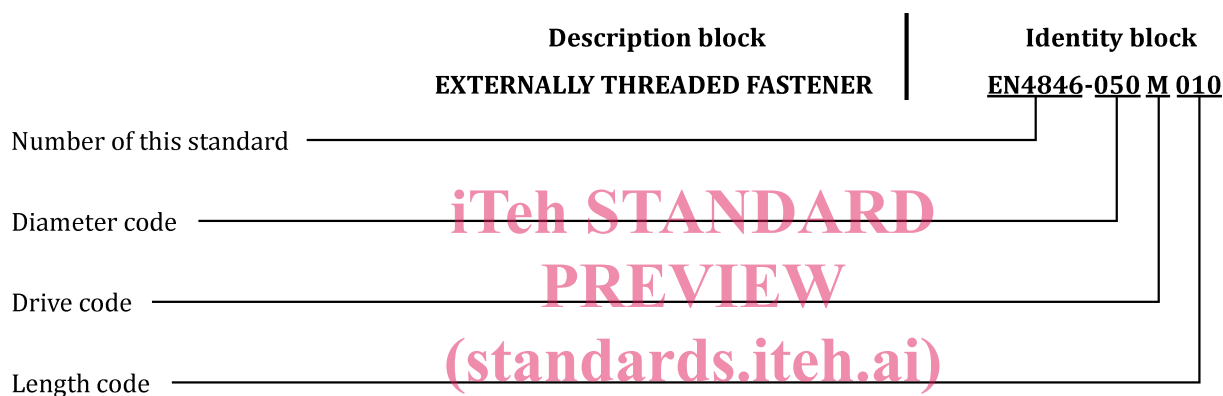
**6 Marking**

SIST EN 4846:2022
<https://standards.iteh.ai/catalog/standards/sist/1e334c85-6181-4f55-b713-73091c64551/sist-en-4846-2022>

Marking shall be indented, see Table 2, Table 3 and Figure 1.

Table 2 — Drive code

Drive	Code
EN 4609	M

Table 3 — Marking

Diameter code	EN 2424 Style
030 and 040	N
050 to 120	C + MJ