



**SLOVENSKI STANDARD**  
**SIST EN 15877-1:2012/oprA1:2017**  
**01-september-2017**

---

**Železniške naprave - Oznake železniških vozil - 1. del: Tovorni vagoni**

Railway applications - Marking on railway vehicles - Part 1: Freight wagons

Bahnanwendungen - Kennzeichnung von Schienenfahrzeugen - Teil 1: Güterwagen

Applications ferroviaires - Inscriptions pour véhicules ferroviaires - Partie 1: Wagons pour le fret

**Ta slovenski standard je istoveten z: EN 15877-1:2012/prA1**

---

**ICS:**

45.060.20      Železniški vagoni      Trailing stock

**SIST EN 15877-1:2012/oprA1:2017      en,fr,de**



EUROPEAN STANDARD  
NORME EUROPÉENNE  
EUROPÄISCHE NORM

**DRAFT**  
**EN 15877-1:2012**  
**prA1**

June 2017

---

ICS 45.060.20

English Version

## Railway applications - Marking on railway vehicles - Part 1: Freight wagons

Applications ferroviaires - Inscriptions pour véhicules  
ferroviaires - Partie 1: Wagons pour le fret

Bahnanwendungen - Kennzeichnung von  
Schienenfahrzeugen - Teil 1: Güterwagen

This draft amendment is submitted to CEN members for enquiry. It has been drawn up by the Technical Committee CEN/TC 256.

This draft amendment A1, if approved, will modify the European Standard EN 15877-1:2012. If this draft becomes an amendment, CEN members are bound to comply with the CEN/CENELEC Internal Regulations which stipulate the conditions for inclusion of this amendment into the relevant national standard without any alteration.

This draft amendment was established by CEN in three official versions (English, French, German). A version in any other language made by translation under the responsibility of a CEN member into its own language and notified to the CEN-CENELEC Management Centre has the same status as the official versions.

CEN members are the national standards bodies of Austria, Belgium, Bulgaria, Croatia, Cyprus, Czech Republic, Denmark, Estonia, Finland, Former Yugoslav Republic of Macedonia, France, Germany, Greece, Hungary, Iceland, Ireland, Italy, Latvia, Lithuania, Luxembourg, Malta, Netherlands, Norway, Poland, Portugal, Romania, Serbia, Slovakia, Slovenia, Spain, Sweden, Switzerland, Turkey and United Kingdom.

Recipients of this draft are invited to submit, with their comments, notification of any relevant patent rights of which they are aware and to provide supporting documentation.

**Warning** : This document is not a European Standard. It is distributed for review and comments. It is subject to change without notice and shall not be referred to as a European Standard.



EUROPEAN COMMITTEE FOR STANDARDIZATION  
COMITÉ EUROPÉEN DE NORMALISATION  
EUROPÄISCHES KOMITEE FÜR NORMUNG

**CEN-CENELEC Management Centre: Avenue Marnix 17, B-1000 Brussels**

---

<b>Contents</b>		Page
<b>European foreword.....</b>		<b>3</b>
<b>1</b>	<b>Modification to the European foreword .....</b>	<b>4</b>
<b>2</b>	<b>Modification to the Introduction .....</b>	<b>4</b>
<b>3</b>	<b>Modification to 4.5.1 .....</b>	<b>4</b>
<b>4</b>	<b>Modification to 4.5.30.2.7.....</b>	<b>8</b>
<b>4.1</b>	<b>Modification to Figure 67 .....</b>	<b>8</b>
<b>4.2</b>	<b>Modification to the Key of Figure 67 .....</b>	<b>10</b>
<b>5</b>	<b>Modification to 4.5.58.....</b>	<b>10</b>
<b>5.1</b>	<b>Modification to Figure 112 .....</b>	<b>10</b>
<b>5.2</b>	<b>Modification to the Key of Figure 112.....</b>	<b>10</b>
<b>6</b>	<b>Modification to Annex ZA .....</b>	<b>11</b>
<b>Annex ZA (informative) Relationship between this European Standard and the Essential Requirements of EU Directive 2008/57/EC aimed to be covered .....</b>		<b>12</b>

## European foreword

This document (EN 15877-1:2012/prA1:2017) has been prepared by Technical Committee CEN/TC 256 “Railway applications”, the secretariat of which is held by DIN.

This document is currently submitted to the CEN Enquiry.

This document has been prepared under a mandate given to CEN by the European Commission and the European Free Trade Association, and supports essential requirements of EU Directive 2008/57/EC.

For relationship with EU Directive 2008/57/EC, see informative Annex ZA, which is an integral part of this document.

EN 15877-1:2012/prA1:2017 (E)

## 1 Modification to the European foreword

*Change the 4th and 5th paragraph as follows:*

“This document has been prepared under a mandate given to CEN by the European Commission and the European Free Trade Association, and supports essential requirements of EU Directive 2008/57/EC.

For relationship with EU Directive 2008/57/EC, see informative Annex ZA, which is an integral part of this document.”

## 2 Modification to the Introduction

*Replace the first two bullet points of the 6th paragraph by:*

“

- the Technical Specification for Interoperability Subsystem: Rolling Stock Scope: Freight Wagons as published in published in the Official Journal L 104, 12.4.2013, p.1, and its amendments;
- the Technical Specification for Interoperability Subsystem: Operation and Traffic Management published in the Official Journal L 165, 30.06.2015, p.1”;

## 3 Modification to 4.5.1

*Replace Figure 4 by the following Figure:*

“

Dimensions in millimetres

31 TEN **GE**  
 80 D-DB  
 0691 235 -2  
 Tanoos

23 TEN **GE**  
 80 D-RFC  
 7369 553 -4  
 Zcs

33 TEN **GE**  
 84 NL-ACTS  
 4796 100 -8  
 Slpss

41 TEN **CW**  
 87 F-SNCF  
 4273 361 -5  
 Laeks

41 TEN  
 87 F-SNCF  
 4273 361 -5  
 Laeks

41  
 87 F-SNCF  
 4273 361 -5  
 Laeks

23 RIV  
 80 CH-SBB  
 7369 005 -0  
 Zcs

23 PPV  
 24 LT-LG  
 4796 813 -1  
 Slpss

Figure 4"

EN 15877-1:2012/prA1:2017 (E)

Replace Figure 5 by the following Figures and keep the current key.:

“

Dimensions in millimetres



a)



b)



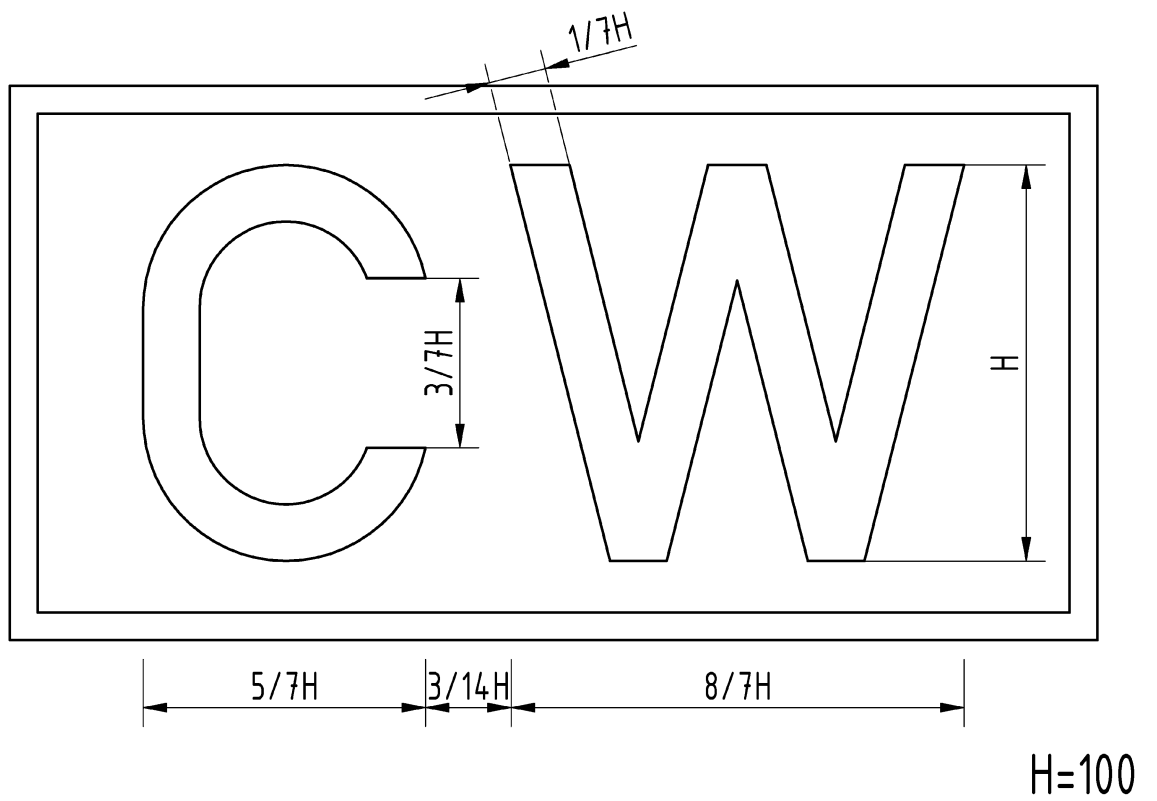
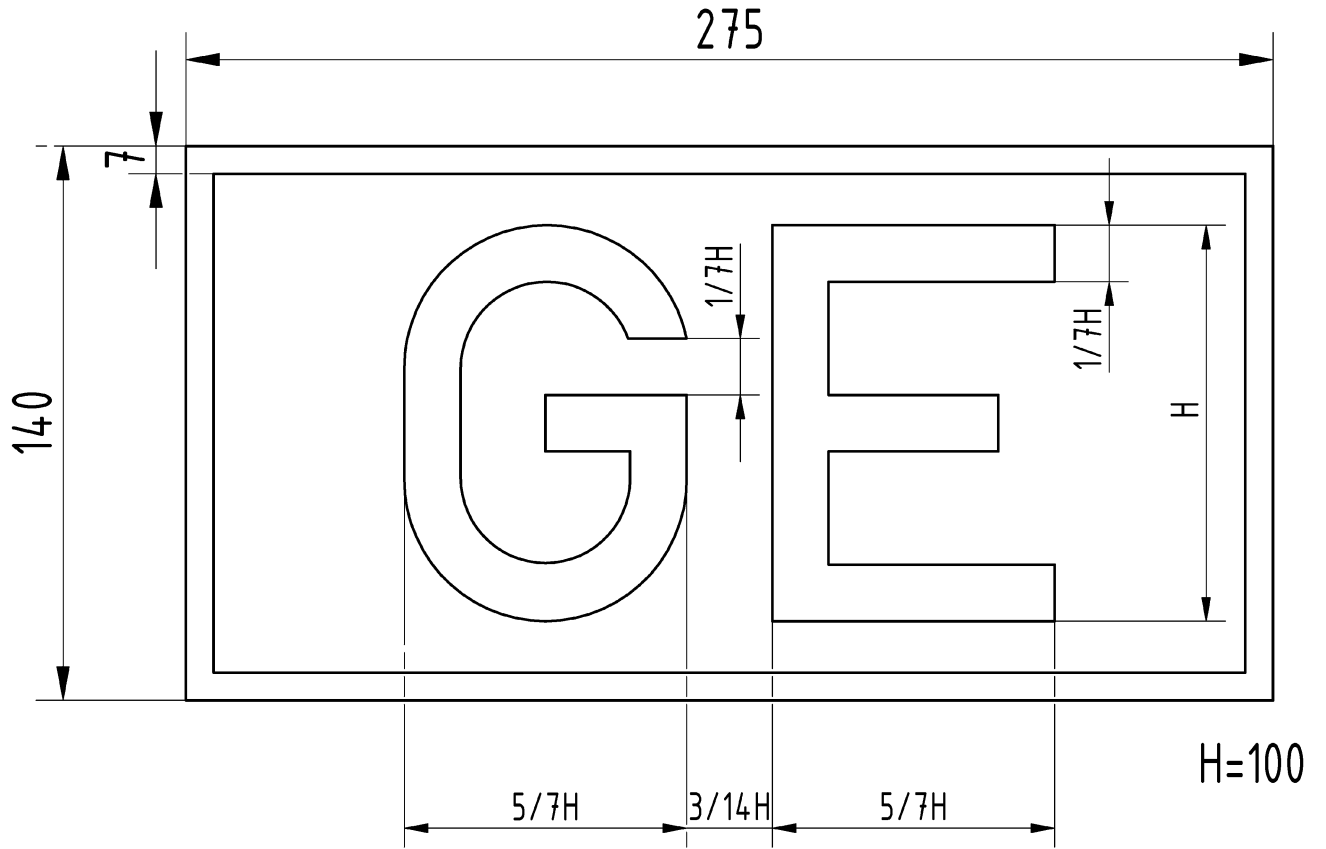

c)''