**Identification cards — Recording
technique —**

**Part 9:
Tactile identifier mark**

Cartes d'identification — Technique d'enregistrement —

Partie 9: Marque d'identificateur tactile

**iTeh STANDARD PREVIEW
(standards.iteh.ai)**

ISO/IEC 7811-9:2015

<https://standards.iteh.ai/catalog/standards/sist/f4d457c6-a46f-4c4a-96f0-ccbb5c893365/iso-iec-7811-9-2015>

iTeh STANDARD PREVIEW
(standards.iteh.ai)

ISO/IEC 7811-9:2015

<https://standards.iteh.ai/catalog/standards/sist/f4d457c6-a46f-4c4a-96f0-ccbb5c893365/iso-iec-7811-9-2015>



COPYRIGHT PROTECTED DOCUMENT

© ISO/IEC 2015, Published in Switzerland

All rights reserved. Unless otherwise specified, no part of this publication may be reproduced or utilized otherwise in any form or by any means, electronic or mechanical, including photocopying, or posting on the internet or an intranet, without prior written permission. Permission can be requested from either ISO at the address below or ISO's member body in the country of the requester.

ISO copyright office
Ch. de Blandonnet 8 • CP 401
CH-1214 Vernier, Geneva, Switzerland
Tel. +41 22 749 01 11
Fax +41 22 749 09 47
copyright@iso.org
www.iso.org

Contents

	Page
Foreword	iv
1 Scope	1
2 Conformance	1
3 Terms and definitions	1
4 TIM physical characteristics	1
4.1 Location of TIM	1
4.2 TIM dot arrangement	2
4.3 Dot dimensions	3
4.4 Sign design	3

iTeh STANDARD PREVIEW (standards.iteh.ai)

[ISO/IEC 7811-9:2015](https://standards.iteh.ai/catalog/standards/sist/f4d457c6-a46f-4c4a-96f0-ccbb5c893365/iso-iec-7811-9-2015)

<https://standards.iteh.ai/catalog/standards/sist/f4d457c6-a46f-4c4a-96f0-ccbb5c893365/iso-iec-7811-9-2015>

Foreword

ISO (the International Organization for Standardization) and IEC (the International Electrotechnical Commission) form the specialized system for worldwide standardization. National bodies that are members of ISO or IEC participate in the development of International Standards through technical committees established by the respective organization to deal with particular fields of technical activity. ISO and IEC technical committees collaborate in fields of mutual interest. Other international organizations, governmental and non-governmental, in liaison with ISO and IEC, also take part in the work. In the field of information technology, ISO and IEC have established a joint technical committee, ISO/IEC JTC 1.

The procedures used to develop this document and those intended for its further maintenance are described in the ISO/IEC Directives, Part 1. In particular the different approval criteria needed for the different types of document should be noted. This document was drafted in accordance with the editorial rules of the ISO/IEC Directives, Part 2 (see www.iso.org/directives).

Attention is drawn to the possibility that some of the elements of this document may be the subject of patent rights. ISO and IEC shall not be held responsible for identifying any or all such patent rights. Details of any patent rights identified during the development of the document will be in the Introduction and/or on the ISO list of patent declarations received (see www.iso.org/patents).

Any trade name used in this document is information given for the convenience of users and does not constitute an endorsement.

For an explanation on the meaning of ISO specific terms and expressions related to conformity assessment, as well as information about ISO's adherence to the WTO principles in the Technical Barriers to Trade (TBT) see the following URL: [Foreword - Supplementary information](#)

The committee responsible for this document is ISO/IEC JTC 1 *Information technology*, Subcommittee SC 17, *Cards and personal identification*.

This second edition cancels and replaces the first edition (ISO/IEC 7811-9:2008), which has been technically revised.

ISO/IEC 7811 consists of the following parts, under the general title *Identification cards — Recording technique*:

- *Part 1: Embossing*
- *Part 2: Magnetic stripe — Low coercivity*
- *Part 6: Magnetic stripe — High coercivity*
- *Part 7: Magnetic stripe — High coercivity, high density*
- *Part 8: Magnetic stripe — Coercivity of 51,7 kA/m (650 Oe)*
- *Part 9: Tactile identifier mark*

Notes in this part of ISO/IEC 7811 are only used for giving additional information intended to assist in the understanding or use of the document. They do not contain provisions or requirements to which it is necessary to conform in order to claim compliance with this part of ISO/IEC 7811.

Identification cards — Recording technique —

Part 9: Tactile identifier mark

1 Scope

This part of ISO/IEC 7811 specifies the physical characteristics of a tactile identifier mark used by visually impaired card holders to distinguish their cards. It defines the area on the card for the TIM and the layout of Braille style embossed dots arranged in patterns to enable easy tactile recognition.

2 Conformance

A TIM is in conformance with this part of ISO/IEC 7811 if it meets all mandatory requirements and optional requirements as specified.

3 Terms and definitions

For the purposes of this document, the terms and definitions given in ISO/IEC 7810 and the following apply.

3.1

TIM

tactile identifier mark

ISO/IEC 7811-9:2015

<https://standards.iteh.ai/catalog/standards/sist/f4d457c6-a46f-4c4a-96f0-ccbb5c893365/iso-iec-7811-9-2015>

3.2

embossed

raised in relief from the front surface of the card by adding or reacting card material or by deforming the card material from the opposite side

4 TIM physical characteristics

4.1 Location of TIM

The TIM should be located on the front surface of the card in the area shown in [Figure 1](#).

The TIM shall not be located outside the name and address area defined by ISO/IEC 7811-1.

Regardless of TIM location, all other raised areas shall be at least 1 mm from the edge of any TIM.

When the technology used to form the raised areas causes a physical deformation of the card such as mechanical embossing, then special care shall be taken that such deformation of the card does not adversely affect the required characteristics of the contained components such as IC, antenna, connecting wires, etc.

A minimum distance of 3 mm between the contained components and any deformed part of the card is recommended unless it is known that the components are not affected by the deformation of the card.

The recommended TIM location is shown in [Figure 1](#) as “Default area”. If the “Alternate area” for TIM is used, there shall be no other raised area to the right and below the TIM dots (between TIM dots and nearest edges of card).

NOTE The alternate area is raised up to avoid overlapping on the antenna of a contactless IC card but is still low enough to be in the name and address area as required and to be at least 1 mm away from the primary account line (both specified in ISO/IEC 7811-1).

Dimensions in millimetres (inches)

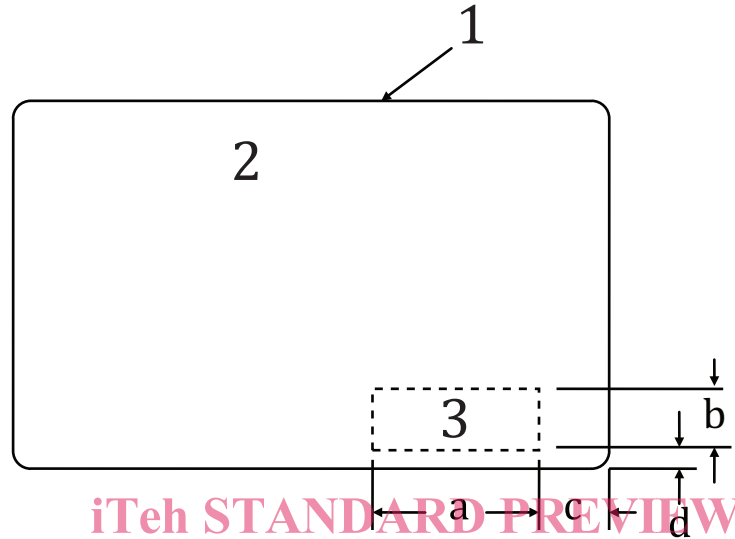

iTeh STANDARD PREVIEW
(standards.iteh.ai)

Key

- 1 top reference edge
- 2 front of card
- 3 TIM area

[ISO/IEC 7811-9:2015](https://standards.iteh.ai/catalog/standards/sist/f4d457c6-a46f-4c4a-96f0-cbb5c893365/iso-iec-7811-9-2015)
<https://standards.iteh.ai/catalog/standards/sist/f4d457c6-a46f-4c4a-96f0-cbb5c893365/iso-iec-7811-9-2015>

	Default area	Alternate area
a	18,5 (0.728) maximum	18,5 (0.728) maximum
b	8 (0.315) maximum	8 (0.315) maximum
c	10 ± 1 (0.394 ± 0.039)	10 ± 1 (0.394 ± 0.039)
d	2,92 ± 0,38 (0.115 ± 0.015)	9,07 ± 0,38 (0.357 ± 0.015)

Figure 1 — TIM area

4.2 TIM dot arrangement

The TIM shall be composed of a maximum of three groups of six dots arranged as shown in [Figure 2](#).

Dimensions in millimetres (inches)

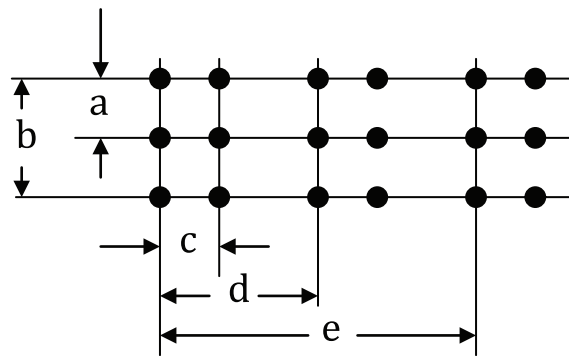

Key

- a 2,3 (0.091)
- b 4,6 (0.181)
- c 2,3 (0.091) three places
- d 6,1 (0.240)
- e 12,2 (0.480)

Figure 2 — Arrangement of TIM dots

4.3 Dot dimensions

Dots used to make up the TIM shall have a relief height of 0,48 mm (0.019 in) maximum and 0,3 mm (0.012 in) minimum above the adjacent surface of the card. The shape of each dot is not specified, examples are shown in Figure 3.

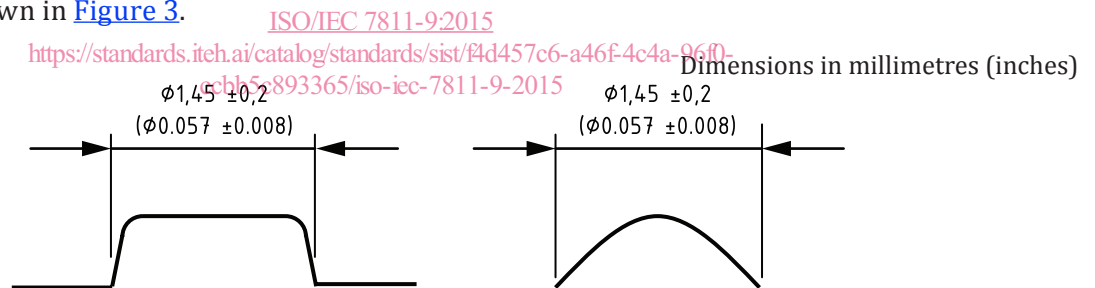

Figure 3 — TIM dot base size and shape illustration

4.4 Sign design

It is recommended that the cardholder select which of the 18 possible dots are to be raised. The maximum number of raised dots is 18 and the minimum is 1.

NOTE Since there are individual differences in discernment by the tactile sense, it is recommended that the card holder be able to use the combination of the dots that is easy for them to discriminate.

iTeh STANDARD PREVIEW
(standards.iteh.ai)

[ISO/IEC 7811-9:2015](https://standards.iteh.ai/catalog/standards/sist/f4d457c6-a46f-4c4a-96f0-ccbb5c893365/iso-iec-7811-9-2015)

<https://standards.iteh.ai/catalog/standards/sist/f4d457c6-a46f-4c4a-96f0-ccbb5c893365/iso-iec-7811-9-2015>