



Designation: ~~D7175-07~~ Designation: D 7175 - 08

## Standard Test Method for Determining the Rheological Properties of Asphalt Binder Using a Dynamic Shear Rheometer<sup>1</sup>

This standard is issued under the fixed designation D 7175; the number immediately following the designation indicates the year of original adoption or, in the case of revision, the year of last revision. A number in parentheses indicates the year of last reapproval. A superscript epsilon ( $\epsilon$ ) indicates an editorial change since the last revision or reapproval.

### 1. Scope

1.1 This test method covers the determination of the dynamic shear modulus and phase angle of asphalt binders when tested in dynamic (oscillatory) shear using parallel plate geometry. It is applicable to asphalt binders having dynamic shear modulus values in the range from 100 Pa to 10 MPa. This range in modulus is typically obtained between 4 and 88°C at 10 rad/s. This test method is intended for determining the linear viscoelastic properties of asphalt binders as required for specification testing and is not intended as a comprehensive procedure for the full characterization of the viscoelastic properties of asphalt binders.

1.2 This standard is appropriate for unaged materials, material aged in accordance with Test Method D 2872, material aged in accordance with Practice D 6521, or material aged in accordance with both Test Method D 2872 and Practice D 6521. This procedure is limited to asphalt binders that contain particles with largest dimension less than 250  $\mu\text{m}$ .

1.3

1.3 The values stated in SI units are to be regarded as standard. No other units of measurement are included in this standard.

1.4 *This standard may involve hazardous materials, operations, and equipment. This standard does not purport to address all of the safety concerns, if any, associated with its use. It is the responsibility of the user of this standard to establish appropriate safety and health practices and determine the applicability of regulatory limitations prior to use.*

### 2. Referenced Documents

#### 2.1 ASTM Standards:<sup>2</sup>

- C 670 Practice for Preparing Precision and Bias Statements for Test Methods for Construction Materials
- D 140 Practice for Sampling Bituminous Materials
- D 2170 Test Method for Kinematic Viscosity of Asphalts (Bitumens)
- D 2171 Test Method for Viscosity of Asphalts by Vacuum Capillary Viscometer
- D 2872 Test Method for Effect of Heat and Air on a Moving Film of Asphalt (Rolling Thin-Film Oven Test)
- D 6373 Specification for Performance Graded Asphalt Binder
- D 6521 Practice for Accelerated Aging of Asphalt Binder Using a Pressurized Aging Vessel (PAV)
- E 77 Test Method for Inspection and Verification of Thermometers
- E 563 Practice for Preparation and Use of an Ice-Point Bath as a Reference Temperature
- E 644 Test Methods for Testing Industrial Resistance Thermometers
- E 882 Guide for Accountability and Quality Control in the Chemical Analysis Laboratory

#### 2.2 AASHTO Standards:<sup>3</sup>

- M320 Standard Specification for Performance-Graded Asphalt Binder
- R29 Practice for Grading or Verifying the Performance Grade of an Asphalt Binder
- T315 Standard Test Method for Determining the Rheological Properties of Asphalt Binder Using a Dynamic Shear Rheometer

#### 2.3 Deutsche Industrie Norm (DIN) Standard:<sup>4</sup>

- 43760 Standard for Calibration of Thermocouples

<sup>1</sup> This test method is under the jurisdiction of ASTM Committee D04 on Road and Paving Materials and is the direct responsibility of Subcommittee D04.44 on Rheological Tests.

Current edition approved Dec. 1, 2007; July 15, 2008. Published January/August 2008. Originally approved in 2005. Last previous edition approved in 2005 as D 7175 - 05.

<sup>2</sup> For referenced ASTM standards, visit the ASTM website, [www.astm.org](http://www.astm.org), or contact ASTM Customer Service at [service@astm.org](mailto:service@astm.org). For *Annual Book of ASTM Standards* volume information, refer to the standard's Document Summary page on the ASTM website.

<sup>3</sup> Available from American Association of State Highway and Transportation Officials (AASHTO), 444 N. Capitol St., NW, Suite 249, Washington, DC 20001, <http://www.transportation.org>.

<sup>4</sup> Available from Beuth Verlag GmbH (DIN-- DIN Deutsches Institut für Normung e.V.), Burggrafenstrasse 6, 10787, Berlin, Germany, <http://www.en.din.de>.

### 3. Terminology

#### 3.1 Definitions of Terms Specific to This Standard:

3.1.1 *annealing, n*—the process of removing the effects of steric hardening by heating the binder until it is sufficiently fluid so that it can be easily poured.

3.1.2 *asphalt binder, n*—an asphalt-based cement that is produced from petroleum residue either with or without the addition of non-particulate modifiers.

3.1.3 *complex shear modulus ( $G^*$ ), n*—ratio calculated by dividing the absolute value of the peak-to-peak shear stress,  $\tau$ , by the absolute value of the peak-to-peak shear strain,  $\gamma$ .

3.1.4 *dummy test specimen, n*—a specimen formed between the DSR test plates from asphalt binder or other polymer for the purpose of determining the temperature in the asphalt binder between the plates.

3.1.4.1 *Discussion*—The dummy test specimen is not used to measure the rheological properties of asphalt binder but is used solely to determine temperature corrections.

3.1.5 *linear viscoelastic, adj*—within context of this test method, refers to a region of behavior in which the dynamic shear modulus is independent of shear stress or strain.

3.1.6 *steric hardening, n*—refers to time-dependent associations that occur between asphalt binder molecules during storage at ambient temperature. The effect of molecular association or steric hardening on the dynamic shear modulus is asphalt specific and may be apparent even after a few hours of storage.

3.1.7 *oscillatory shear, n*—refers to a type of loading in which a shear stress or shear strain is applied to a test sample in an oscillatory manner such that the shear stress or strain varies in amplitude about zero in a sinusoidal manner.

3.1.8 *parallel plate geometry, n*—refers to a testing geometry in which the test specimen is sandwiched between two rigid parallel plates and subjected to shear.

3.1.9 *phase angle ( $\delta$ ), n*—the angle in degrees between a sinusoidally applied strain and the resultant sinusoidal stress in a controlled-strain testing mode, or between the applied stress and the resultant strain in a controlled-stress testing mode.

3.1.10 *portable temperature measuring device, n*—refers to an electronic device that is separate from the dynamic shear rheometer and that consists of a detector (probe containing a thermocouple or resistive element), associated electronic circuitry, and readout system.

3.1.11 *reference temperature measuring device, n*—refers to a NIST-traceable liquid-in-glass or electronic thermometer that is used as a laboratory standard.

3.1.12 *thermal equilibrium, n*—condition where the temperature of the test specimen mounted between the test plates is constant with time.

### 4. Summary of Test Method

4.1 This standard contains the procedure used to measure the complex shear modulus ( $G^*$ ) and phase angle ( $\delta$ ) of asphalt binders using dynamic shear rheometer and parallel plate geometry.

4.2 The standard is suitable for use when the dynamic shear modulus varies between 100 Pa and 10 MPa. This range in modulus is typically obtained between 4 and 88°C, depending upon the grade, test temperature, and conditioning (aging) of the asphalt binder.

4.3 Test specimens, nominally 25 mm in diameter by 1 mm thick or 8 mm in diameter by 2 mm thick, are formed between parallel metal plates.

4.4 During testing, one of the parallel plates is oscillated with respect to the other at pre-selected frequencies and angular deflection (or torque) amplitudes. The required amplitude depends upon the value of the complex shear modulus of the asphalt binder being tested. The required amplitudes have been selected so that, for most asphalt binders, the testing specified in this standard is within the region of linear behavior.

4.5 The test specimen is maintained at the test temperature  $\pm 0.1^\circ\text{C}$  by enclosing the upper and lower plates in a thermally controlled environment or test chamber.

4.6 Oscillatory loading frequencies using this standard can range from 1 to 160 rad/s. Specification testing is performed at a test frequency of 10 rad/s. The complex modulus ( $G^*$ ) and phase angle ( $\delta$ ) are calculated automatically as part of the operation of the rheometer using proprietary computer software supplied by the instrument manufacturer.

### 5. Significance and Use

5.1 The test temperature for this test is related to the temperature experienced by the pavement in the geographical area for which the asphalt binder is intended to be used.

5.2 The complex shear modulus is an indicator of the stiffness or resistance of asphalt binder to deformation under load. The complex shear modulus and the phase angle define the resistance to shear deformation of the asphalt binder in the linear viscoelastic region. The complex modulus and the phase angle are used to calculate performance-related criteria in accordance with Specification D 6373 or AASHTO Standard M320.

### 6. Interferences

6.1 Particulate material in the asphalt binder is limited to particles with longest dimensions less than 250  $\mu\text{m}$ . Particles with

dimensions greater than 250  $\mu\text{m}$  approach the dimensions of the gap (1000  $\mu\text{m}$ ). In order to accurately characterize a two-phase material containing particulate material it is well accepted that the thickness of the test specimen must be at least four times the maximum particle size.

6.1.1 The calculation of the complex modulus from the data obtained from the DSR is highly dependent upon an accurate measurement of the diameter of the test specimen. In the procedure, the diameter of the test specimen is assumed equal to the diameter of the test plates. This assumption is valid only if the test sample is properly trimmed.

6.1.2 The physical properties of asphalt binders are very sensitive to test temperature and thermal history. Thermal history is the number of times asphalt binder sample has been heated prior to testing. Controlling the test temperature to  $\pm 0.1^\circ\text{C}$  and limiting the number of times the asphalt sample is heated prior to testing (only one heating is recommended) is essential in order to obtain repeatable test results within a laboratory as well as to reproduce results between laboratories.

## 7. Apparatus

7.1 *Dynamic Shear Rheometer (DSR) Test System*—A dynamic shear rheometer test system consisting of parallel metal plates, a means for controlling the temperature of the test specimen, a loading device, and a control and data acquisition system. The manufacturer of the device shall provide a certificate certifying that the frequency, deflection angle, and torque are controlled, measured, or both, with accuracy of 1 % or less in the range of this measurement.

7.1.1 *Test Plates*—Metal plates cylindrical in shape, formed from steel or aluminum, with smooth ground surfaces are required. Two plates  $8.00 \pm 0.02$  mm in diameter and two plates  $25.00 \pm 0.05$  mm in diameter are required. The test plates shall have a minimum thickness or raised portion of 1.5 mm to allow sufficient clearance for trimming the specimen. The plates shall be formed as an integral part of the test fixtures that are used to mount the plates in the DSR as shown in Fig. 1.

NOTE 1—The upper and lower plates should be concentric with each other. At the present there is no suitable procedure for the user to check the concentricity except to visually observe whether or not the upper and lower plates are centered with respect to each other. The moveable plate should rotate without any observable horizontal or vertical wobble. This may be checked visually or with a dial gage held in contact with the edge of the moveable plate while it is being rotated.

7.1.2 *Environmental Chamber*—A chamber for controlling the temperature of the test specimen. The medium for heating and cooling the specimen in the environmental chamber shall not affect asphalt binder properties. The temperature in the chamber may be controlled by the circulation of fluid—conditioned gas, nitrogen or water is acceptable—or by a suitable arrangement of actively temperature controlled heating elements (for example, solid state Peltier elements) surrounding the sample. When laboratory air is used in a forced air oven, a suitable dryer must be included to prevent condensation of moisture on the test plates. The environmental chamber and the temperature controller shall control the temperature of the test specimen mounted between the test plates, including any thermal gradients within the test specimen, at the test temperature  $\pm 0.1^\circ\text{C}$ . The chamber or the water in the chamber shall completely enclose the top and the bottom plates to minimize thermal gradients within the fixtures and test specimen.

NOTE 2—A circulating bath unit, separate from the DSR that pumps the water through the test chamber may be required if a fluid medium is used.

7.1.2.1 *Temperature Controller*—A temperature controller capable of maintaining the temperature of the test specimen at the test temperature for the entire range of test temperatures.

7.1.3 *Internal DSR Temperature Measurement Device*—A platinum resistance temperature measurement device (PRT) mounted within the environmental chamber as an integral part of the DSR and in close proximity to the fixed plate, with a range of 4 to  $88^\circ\text{C}$ , and with a resolution of  $0.1^\circ\text{C}$ . This temperature measurement device shall be used to control the temperature of the test specimen between the plates and shall provide a continuous readout of temperature during the mounting, conditioning, and testing of the specimen.

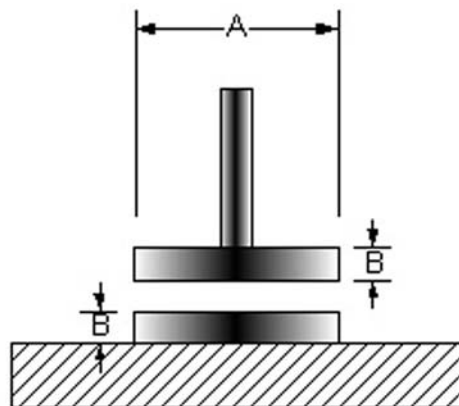

Dimension	8-mm Nominal	25-mm Nominal
A	$8 \pm 0.1$ mm	$25 \pm 0.5$ mm
B	$> 1.5$ mm	$> 1.5$ mm

**FIG. 1 Plate Dimensions**

7.1.4 *Loading Device*—The loading device shall be capable of applying a sinusoidal oscillatory load to the specimen at a frequency of  $10.0 \pm 0.1$  rad/s. If frequencies other than 10 rad/s are used, the frequency shall be accurate to 1 percent. The loading device shall be capable of providing either a stress controlled or strain controlled load within a range of stress or strain necessary to make the measurements described in this test method.

7.1.5 *Data Acquisition System*—The data acquisition system shall provide a record of temperature, frequency, deflection angle, and torque. The manufacturer of the rheometer shall provide a certificate certifying that the frequency, deflection angle, and torque are reported with an accuracy of at least 1 %.

7.2 *Specimen Mold (optional)*—The overall dimensions of the silicone rubber mold for forming asphalt binder test specimens may vary but the overall thickness shall be at least 5 mm thick.

NOTE 3—The following dimensions have been found suitable: For a 25-mm test plate with a 1-mm gap a mold cavity with a concave bottom with an approximate diameter of 18 mm and a depth of at least 2.0 mm and for an 8-mm test plate with a 2-mm gap a mold cavity with a concave bottom with an approximate diameter of 8 mm and a depth of at least 2.5 mm.

7.3 *Trimming Tool*—A tool suitable for trimming excess binder from the periphery of the test specimen to produce a smooth face on the test specimen that is parallel and coincident with the outer diameter of the upper and lower plates.

7.4 *Reference Temperature Measurement Device*—Either a NIST-traceable liquid-in-glass thermometer(s) (see 7.4.1) or NIST-traceable digital electronic thermometer (see 7.4.2) shall be maintained in the laboratory as a temperature standard.

7.4.1 *Liquid-in-Glass Thermometer*—NIST-traceable liquid-in-glass thermometer(s) with a range between 0 to 88°C and with subdivisions of 0.1°C. The thermometer(s) shall be partial immersion thermometers with an ice point. The liquid-in-glass thermometers shall be verified at least once a year in accordance with test method Test Method E 77 and Practice E 563.

NOTE 4—An Optical Viewing Device is recommended as an optional viewing device for use with liquid-in-glass thermometers because it enhances readability and minimizes parallax when reading the liquid-in-glass reference thermometer.

7.4.2 *Digital Temperature Measurement Device*—An electronic thermometer that incorporates a thermometric device or resistive detector with an accuracy of  $\pm 0.05^\circ\text{C}$  and a resolution of  $0.01^\circ\text{C}$ . The electronic thermometer shall be calibrated at least once per year by a commercial calibrating service using a NIST-traceable reference standard in accordance with Test Methods E 644.

7.5 *Portable Temperature Measurement Device*—A calibrated portable thermometer consisting of a thermometric device or resistive detector, associated electronic circuitry, and digital readout. The thickness of the detector shall be no greater than 2.0 mm such that it can be inserted between the test plates.

7.5.1 The reference temperature measurement device (see 7.4) may be used for this purpose if its detector fits within the dummy specimen as required by 9.4.2. The calibration and accuracy of the reference temperature detector specified in Section 7.4 shall replace the standardization requirement in Section 7.5.

NOTE 5—Guide E 882 may be used for evaluating test data. [ASTM D7175-08](https://standards.iteh.ai/catalog/standards/sist/3e7df447-d097-44b2-a24a-bb3ee6bb99fd/astm-d7175-08)

## 8. Materials

8.1 *Wiping Material*—Clean cloth, paper towels, cotton swabs or other suitable material as required for wiping the plates.

8.2 *Cleaning Solvents*:

Solvents for cleaning the plates shall leave no residue on the surface of the plates.

NOTE 6—Mineral oil, citrus-based solvents, mineral spirits, toluene, or similar solvents have been found to be suitable for cleaning the plates. Organic solvent that does not leave a residue such as heptane, acetone, or ethyl alcohol can also be used for removing solvent residue from the surfaces of the plates.

## 9. Verification

9.1 Verify the DSR and its components as described in this section when the DSR is newly installed, when it is moved to a new location, and/or whenever the accuracy of the DSR and/or any of its components is suspect. Four items require verification: test plate diameter, DSR torque transducer, portable thermometer, and DSR test specimen temperature. Verify the DSR temperature before verifying the torque transducer.

9.2 *Verification of Plate Diameter*— Before first using an upper or lower test plate, measure its diameter (average of 3 different locations  $\sim 120^\circ$  apart) to the nearest 0.02 mm. Verify that the plates are in compliance with the requirements specified in 7.1.1. Maintain a log of the measured diameters so that the measurements are clearly identified with specific plates.

9.3 *Verification of Portable Thermometer*—Verify the portable thermometer (used to measure the temperature between the test plates) at intervals of six months or less using the laboratory reference thermometer. If the reference thermometer (see 7.4) is also used as a portable thermometer to measure the temperature between the test plates, it shall be verified as per 9.3.1. Electronic thermometers shall be verified using the same meters and circuitry (wiring) that are used when temperature measurements are made between the plates.

9.3.1 *Recommended Verification Procedure*— Bring the reference thermometer into intimate contact with the detector from the portable thermometer and place them in a thermostatically controlled and stirred water bath (see Note 7). Ensure that de-ionized water is used to prevent electrical conduction from occurring between electrodes of the resistive temperature sensitive element. If

this is not available, encase the reference thermometer and the detector of the portable thermometer into a water proof plastic bag prior to placement into the bath. Obtain measurements at intervals of 6°C over the range of test temperatures allowing the bath to come to thermal equilibrium at each temperature. If the readings of the portable thermometer and the reference thermometer differ by 0.1°C or more, record the difference at each temperature as a temperature correction and maintain the corrections in a log.

NOTE 7—A recommended procedure is to use a stirred water bath that is controlled to  $\pm 0.1^\circ\text{C}$  such as the viscosity bath used for Test Method D 2170 or Test Method D 2171. Bring the probe from the portable thermometer into contact with the reference thermometer and hold the assembly in intimate contact. A rubber band works well for this purpose. Immerse the assembly in the water bath and bring the water bath to thermal equilibrium. Record the temperature on each device when thermal equilibrium is reached.

9.4 *Temperature Offset*—Thermal gradients within the rheometer can cause differences between the temperature of the test specimen and the temperature indicated by the DSR thermometer (also used to control the temperature of the DSR). When these differences are 0.1°C or greater, determine a temperature correction by using a thermal detector mounted in a silicone rubber wafer (see 9.4.1) or by placing asphalt binder (dummy sample) between the plates and inserting the detector of the portable thermometer into the asphalt binder (see 9.4.2). The temperature offset shall be verified each time the portable thermometer is verified.

9.4.1 *Method Using Silicone Rubber Wafer*—Place the wafer between the 25 mm test plates and close the gap to bring the wafer into contact with the upper and lower plate so that the silicone rubber makes complete contact with the surfaces of the upper and lower plates. If needed, apply a thin layer of petroleum grease or anti-seize compound (see Note 8) to completely fill any void space between the silicone rubber and the plates. Complete contact is needed to ensure proper heat transfer across the plates and silicone rubber wafer (see Note 9) Determine any needed temperature correction as per 9.4.3.

NOTE 8—Anti-seize compound available by that name at hardware and the auto supply stores is much less apt to contaminate the circulating water than petroleum jelly.

NOTE 9—The currently available silicone wafer is 2 mm thick and slightly greater than 25 mm in diameter.

9.4.2 *Method Using Dummy Test Specimen*—The dummy test specimen shall be formed from asphalt binder, or other polymer that can be readily formed between the plates. Mount the dummy test specimen between the test plates and insert the detector (probe) of the portable thermometer into the dummy test specimen. Close the gap to the test gap (1 mm for 25-mm plates and 2 mm for 8-mm plates) keeping the detector centered vertically and radially in the dummy test specimen. Heat the plates as needed to allow the dummy test specimen to completely fill the gap between the test plates. It is not necessary to trim the dummy test specimen but avoid excessive material around the edges of the plates. Develop control charts using Guide E 882. Determine any needed temperature correction as per 9.4.3.

NOTE 10—Silly putty can leave a residue of silicone oil on the surfaces of the plates and for this reason its use as a dummy specimen is not recommended.

9.4.3 *Determination of Temperature Offset*—Obtain simultaneous temperature measurements with the DSR thermometer and the portable thermometer at 6°C increments to cover the range of test temperatures. At each temperature increment, after thermal equilibrium has been reached, record the temperature indicated by the portable thermometer and the DSR thermometer to the nearest 0.1°C. Temperature equilibrium is reached when the temperature indicated by both the DSR thermometer and the portable thermometer do not vary by more than 0.1°C over a five minute time period. Obtain additional measurements to include the entire temperature range that will be used for measuring the dynamic shear modulus.

9.4.4 *Plot Offset versus Specimen Temperature (optional)*—Using the data obtained in 9.4.3, prepare a plot of the difference between the two temperature measurements versus the temperature measured with the portable thermometer, Fig. 2. This difference is the temperature correction that must be applied to the DSR temperature controller to obtain the desired temperature in the test specimen between the test plates. Report the temperature correction at the respective test temperature from the plot and report the corrected test temperature between the plates as the test temperature. Alternatively, the instrument software may be written to incorporate these temperature corrections.

NOTE 11—The difference between the two temperature measurements may not be a constant for a given rheometer but may vary with differences between the test temperature and the ambient laboratory temperature as well as with fluctuations in ambient temperature. The difference between the two temperature measurements is caused in part by thermal gradients in the test specimen and fixtures.

9.5 *Verification of DSR*—Verify the accuracy of the torque transducer and angular displacement transducer whenever the DSR is newly installed, when it is moved, every six months, each time temperature offset is verified, and/or whenever the accuracy of measurements with the DSR is suspect.

NOTE 12—A newly installed or reconditioned instrument should be verified on a weekly basis using the procedures in 9.5 until acceptable verification has been demonstrated. Maintaining the data in the form of a control chart where the verification measurements are plotted versus calendar date is recommended (see Appendix X2).

9.5.1 *Verification of Torque Transducer*—Verify the calibration of the torque transducer using a reference fluid or manufacturer-supplied fixtures whenever the calibration of the torque transducer is suspect and/or when the dynamic viscosity, as measured for the reference fluid, indicates that the torque transducer is not in calibration.

9.5.1.1 *Verification of Torque Transducer with Reference Fluid* (see Annex A1)—The complex viscosity measured with the DSR shall be within 3 percent of the capillary viscosity as reported by the manufacturer of the reference fluid, otherwise the calibration

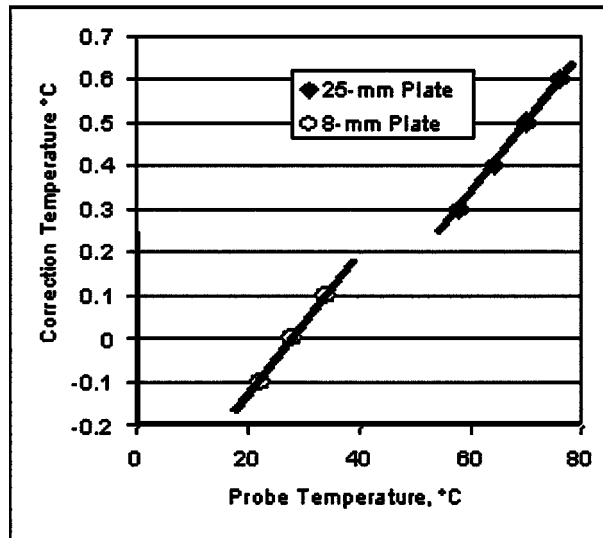

FIG. 2 Determination of Temperature Correction

of the torque transducer shall be considered suspect. Calculate the complex viscosity as the complex modulus,  $G^*$  divided by the angular frequency in rad/s. If the requirements of this section can not be met, discontinue use of the device and consult the manufacturer or other qualified service personnel.

NOTE 13—A suitable reference fluid is available from Cannon Instrument Company as viscosity standard number N2700000SP.

9.5.1.2 *Verification of Torque Transducer with Fixtures*—Verify the calibration of the torque transducer using the manufacturer-supplied fixtures in accordance with the instructions supplied by the manufacturer. Suitable manufacturer-supplied fixtures are not widely available. If suitable fixtures are not available, this requirement shall be waived.

9.5.2 *Verification of Angular Displacement Transducer*—If manufacturer-supplied fixtures are available, verify the calibration every six months and/or whenever the calibration of the DSR is suspect. If suitable fixtures are not available, this requirement shall be waived.

## 10. Preparation of Apparatus

10.1 Prepare the apparatus for testing in accordance with the manufacturer's recommendations. Specific requirements will vary for different DSR models and manufacturers.

10.2 *Inspect Test Plates*—Inspect the surfaces of the test plates and discard any plates with jagged or rounded edges or deep scratches.

10.3 *Preparation of Test Plates*—Clean any asphalt binder residue from the plates with an organic solvent such as mineral oil, mineral spirits, a citrus-based solvent, or toluene. Remove any remaining solvent residue by wiping the surface of the plates with a cotton swab or a soft cloth dampened with reagent grade organic solvent such as heptane, ethyl alcohol, or acetone. If necessary, use a dry cotton swab or soft cloth to ensure that no moisture condenses on the plates.

10.4 *Mount Test Plates and Fixtures*—Mount the test plates and fixtures in the DSR taking care to visually ensure that the plates are parallel to each other and tighten the plates and fixtures to firmly seat them into the DSR, taking care to ensure that the plates are parallel to each other.

10.5 *Zero Gap*—Select the testing temperature according to the expected grade of the asphalt binder or according to the pre selected testing schedule. When multiple test temperatures are used, zero the gap at the middle of the expected range of test temperatures. Allow the DSR to reach a stabilized temperature within  $\pm 0.1^\circ\text{C}$  of test temperature. If the test temperature differs by more than  $\pm 12^\circ\text{C}$  from the temperature at which the gap is set, re-zero the gap. Zero the gap prior to each time a new specimen is formed between the plates.

NOTE 14—If the instrument has thermal gap compensation, the gap may be set at the first test temperature instead of in the middle of the range of test temperatures. It is very important to set and zero the gap correctly. Incorrect gap setting produces significant errors as shown in Fig. 3.

NOTE 15—Specification D 6373 and AASHTO Practice R29 provide guidance on the selection of test temperatures.

10.5.1 *Determining Zero Gap*—Establish the zero gap by one of three methods.

10.5.1.1 *Manual Gap Setting*—Spin the moveable plate, and while the moveable plate is spinning, close the gap until the movable plate touches the fixed plate. The zero gap is reached when the plate just stops spinning completely.

10.5.1.2 *Normal Force Transducer*—For rheometers with normal force transducers, set the zero gap by closing the gap and observing the normal force. After establishing contact between the plates, set the zero gap as the position where the normal force is approximately zero.