

---

---

**Steel — Determination of content of  
nonmetallic inclusions — Micrographic  
method using standard diagrams**

*Aciers — Détermination de la teneur en inclusions non métalliques —  
Méthode micrographique à l'aide d'images types*

**iTeh STANDARD PREVIEW**  
**(standards.iteh.ai)**

[ISO 4967:2013](https://standards.iteh.ai/catalog/standards/sist/631317f1-2dc3-40f5-bfcc-025c6035b946/iso-4967-2013)

<https://standards.iteh.ai/catalog/standards/sist/631317f1-2dc3-40f5-bfcc-025c6035b946/iso-4967-2013>



**iTeh STANDARD PREVIEW**  
**(standards.iteh.ai)**

ISO 4967:2013

<https://standards.iteh.ai/catalog/standards/sist/631317f1-2dc3-40f5-bfcc-025c6035b946/iso-4967-2013>



**COPYRIGHT PROTECTED DOCUMENT**

© ISO 2013

All rights reserved. Unless otherwise specified, no part of this publication may be reproduced or utilized otherwise in any form or by any means, electronic or mechanical, including photocopying, or posting on the internet or an intranet, without prior written permission. Permission can be requested from either ISO at the address below or ISO's member body in the country of the requester.

ISO copyright office  
Case postale 56 • CH-1211 Geneva 20  
Tel. + 41 22 749 01 11  
Fax + 41 22 749 09 47  
E-mail [copyright@iso.org](mailto:copyright@iso.org)  
Web [www.iso.org](http://www.iso.org)

Published in Switzerland

# Contents

	Page
<b>Foreword</b> .....	<b>iv</b>
<b>1 Scope</b> .....	<b>1</b>
<b>2 Principle</b> .....	<b>1</b>
<b>3 Sampling</b> .....	<b>2</b>
<b>4 Preparation of specimens</b> .....	<b>6</b>
<b>5 Determination of the content of inclusions</b> .....	<b>6</b>
5.1 Method of observation.....	6
5.2 Actual examination.....	7
<b>6 Expression of results</b> .....	<b>9</b>
6.1 General.....	9
6.2 Case of method A.....	9
6.3 Case of method B.....	9
<b>7 Test report</b> .....	<b>10</b>
<b>Annex A (normative) ISO Chart diagrams for inclusion groups A, B, C, D and DS</b> .....	<b>11</b>
<b>Annex B (informative) Assessment of a field and of oversized inclusions or stringers</b> .....	<b>26</b>
<b>Annex C (informative) Typical example of results (the total number of fields showing the index, by type of inclusion, for a given number of fields observed)</b> .....	<b>29</b>
<b>Annex D (informative) Relationship between chart diagram indices and inclusion measurements</b> .....	<b>33</b>

ISO 4967:2013

<https://standards.iteh.ai/catalog/standards/sist/631317f1-2dc3-40f5-bfcc-025c6035b946/iso-4967-2013>

## Foreword

ISO (the International Organization for Standardization) is a worldwide federation of national standards bodies (ISO member bodies). The work of preparing International Standards is normally carried out through ISO technical committees. Each member body interested in a subject for which a technical committee has been established has the right to be represented on that committee. International organizations, governmental and non-governmental, in liaison with ISO, also take part in the work. ISO collaborates closely with the International Electrotechnical Commission (IEC) on all matters of electrotechnical standardization.

The procedures used to develop this document and those intended for its further maintenance are described in the ISO/IEC Directives, Part 1. In particular the different approval criteria needed for the different types of ISO documents should be noted. This document was drafted in accordance with the editorial rules of the ISO/IEC Directives, Part 2. [www.iso.org/directives](http://www.iso.org/directives)

Attention is drawn to the possibility that some of the elements of this document may be the subject of patent rights. ISO shall not be held responsible for identifying any or all such patent rights. Details of any patent rights identified during the development of the document will be in the Introduction and/or on the ISO list of patent declarations received. [www.iso.org/patents](http://www.iso.org/patents)

Any trade name used in this document is information given for the convenience of users and does not constitute an endorsement.

The committee responsible for this document is ISO/TC 17, *Steel*, Subcommittee SC 7, *Methods of testing (other than mechanical tests and chemical analysis)*.

This third edition cancels and replaces the second edition (ISO 4967:1998), of which it constitutes a minor revision.

[ISO 4967:2013](https://standards.iteh.ai/catalog/standards/sist/631317f1-2dc3-40f5-bfcc-025c6035b946/iso-4967-2013)

<https://standards.iteh.ai/catalog/standards/sist/631317f1-2dc3-40f5-bfcc-025c6035b946/iso-4967-2013>

# Steel — Determination of content of nonmetallic inclusions — Micrographic method using standard diagrams

## 1 Scope

This International Standard specifies a micrographic method of determining the non-metallic inclusions in rolled or forged steel products having a reduction ratio of at least 3 using standard diagrams. This method is widely used to assess the suitability of a steel for a given use. However, since it is difficult to achieve reproducible results owing to the influence of the test operator, even with a large number of specimens, precautions should be taken when using the method.

NOTE For certain types of steel (e.g. free cutting steels), the standardized diagrams described in this International Standard may not be applicable.

This International Standard also provides for the determination of non-metallic inclusions by image analysis technologies (see [Annex D](#)).

## 2 Principle

The method consists of comparing the observed field to the chart diagrams defined in this International Standard and taking in consideration separately each type of inclusion. In the case of image analysis, fields will be rated according to the relationships given in [Annex D](#).

The chart pictures correspond to square fields of view, each with an area of 0,50 mm<sup>2</sup>, as obtained with a longitudinal plane-of-polish and as observed at 100 $\times$ .

According to the shape and distribution of the inclusions, the standard diagrams are divided into five main groups, bearing the reference A, B, C, D and DS.

These five groups represent the most commonly observed inclusion types and morphologies:

- **Group A (sulfide type):** highly malleable, individual grey particles with a wide range of aspect ratios (length/width) and generally rounded ends;
- **Group B (aluminate type):** numerous non deformable, angular, low aspect ratio (generally < 3), black or bluish particles (at least three) aligned in the deformation direction;
- **Group C (silicate type):** highly malleable, individual black or dark grey particles with a wide range of aspect ratios (generally > 3) and generally sharp ends;
- **Group D (globular oxide type):** non deformable, angular or circular, low aspect ratio (generally < 3), black or bluish, randomly distributed particles;
- **Group DS (single globular type):** circular, or nearly circular, single particle with a diameter > 13  $\mu\text{m}$ .

Non-traditional inclusion types may also be rated based on their morphology compared to the above five types and a statement about their chemical nature. As an example, globular sulfides would be rated as a D type and a descriptive subscript (e.g. D<sub>Sulf</sub>) defined in the test report. D<sub>Cas</sub> would indicate globular calcium sulfides; D<sub>RES</sub> would indicate globular rare earth sulfides; D<sub>Dup</sub> would indicate globular duplex inclusions, such as calcium sulfide surrounding an aluminate.

Types of precipitate such as borides, carbides, carbonitrides or nitrides may also be rated based on their morphology compared to the above five types and a statement about their chemical nature as described in the previous subclause.

NOTE Examination at a magnification greater than 100 × may be used to identify the nature of the non-traditional inclusions before performing the test.

Each main group on the chart consists of two subgroups, each made up of six diagrams representing increasing inclusion content. This division into subgroups is merely intended to give examples of different thicknesses of non-metallic particles.

The diagrams on the chart are given, by inclusion group, in [Annex A](#).

These chart diagrams carry an index number, *i*, from 0,5 to 3, the numbers increasing with the inclusion or stringer lengths (Groups A, B, C) or by the number (Group D) or by the diameter (Group DS), as defined in [Table 1](#), and by thickness, as defined in [Table 2](#). For example, the diagram A 2 indicates that the shape of the inclusions observed under the microscope is in accordance with group A and that their distribution and quantity are in accordance with number 2.

**Table 1 — Rating limits (minimum values)**

Chart diagram Index <i>i</i>	Inclusion group				
	A total length μm	B total length μm	C total length μm	D count number	DS diameter μm
0,5	37	17	18	1	13
1	127	77	76	4	19
1,5	261	184	176	9	27
2	436	343	320	16	38
2,5	649	555	510	25	53
3	898	822	746	36	76
	(< 1 181)	(< 1 147)	(< 1 029)	(< 49)	(< 107)

NOTE The above length values for the A, B and C groups have been computed from the equations given in [Annex D](#) and then rounded off to the nearest whole number.

**Table 2 — Inclusion thickness parameters**

Group type	Fine		Thick	
	Minimum width μm	Maximum width μm	Minimum width μm	Maximum width μm
A	2	4	4	12
B	2	9	9	15
C	2	5	5	12
D	2	8	8	13

NOTE For type D, the maximum dimension is defined as the diameter.

### 3 Sampling

The shape of the inclusion depends to a large extent on the degree of reduction of the steel; therefore, comparative measurements may only be carried out on prepared sections taken from samples with a similar amount of deformation.

The polished surface of the specimen used to determine the content of inclusions shall be approximately 200 mm<sup>2</sup> (20 mm × 10 mm). It shall be parallel to the longitudinal axis of the product and shall be located halfway between the outer surface and the centre.

The method of sampling shall be defined in the product standard or subject to agreement between the parties. The test surface, in the case of plates, shall be approximately at a quarter of the width.

In the absence of such specifications, the sampling procedure shall be as follows:

- bar or billet with diameters greater than 40 mm: the surface to be examined consists of a part of diametral section located halfway between the outer surface and the centre (see [Figure 1](#));
- bar with a diameter greater than 25 mm and less than or equal to 40 mm: the surface to be examined consists of half the diametral section (from the centre to the edge of the sample) (see [Figure 2](#));
- bar with a diameter less than or equal to 25 mm: the surface to be examined consists of the full diametral section of length sufficient to obtain a surface of about 200 mm<sup>2</sup> (see [Figure 3](#));
- plate with a thickness less than or equal to 25 mm: the surface to be examined consists of the whole thickness, and located at the quarter of the width (see [Figure 4](#)),
- plate with a thickness greater than 25 mm and less than or equal to 50 mm: the surface to be examined consists of half the thickness from the surface to the centre and is located at the quarter of the width (see [Figure 5](#));
- plate with a thickness greater than 50 mm: the surface to be examined consists of quarter the thickness and is located halfway between the outer surface and the middle of the thickness and at the quarter of the width (see [Figure 6](#)).

The number of samples to be taken is defined in the product standard or by special agreement.

For any other product, the sampling procedures shall be subject to agreement between the parties.

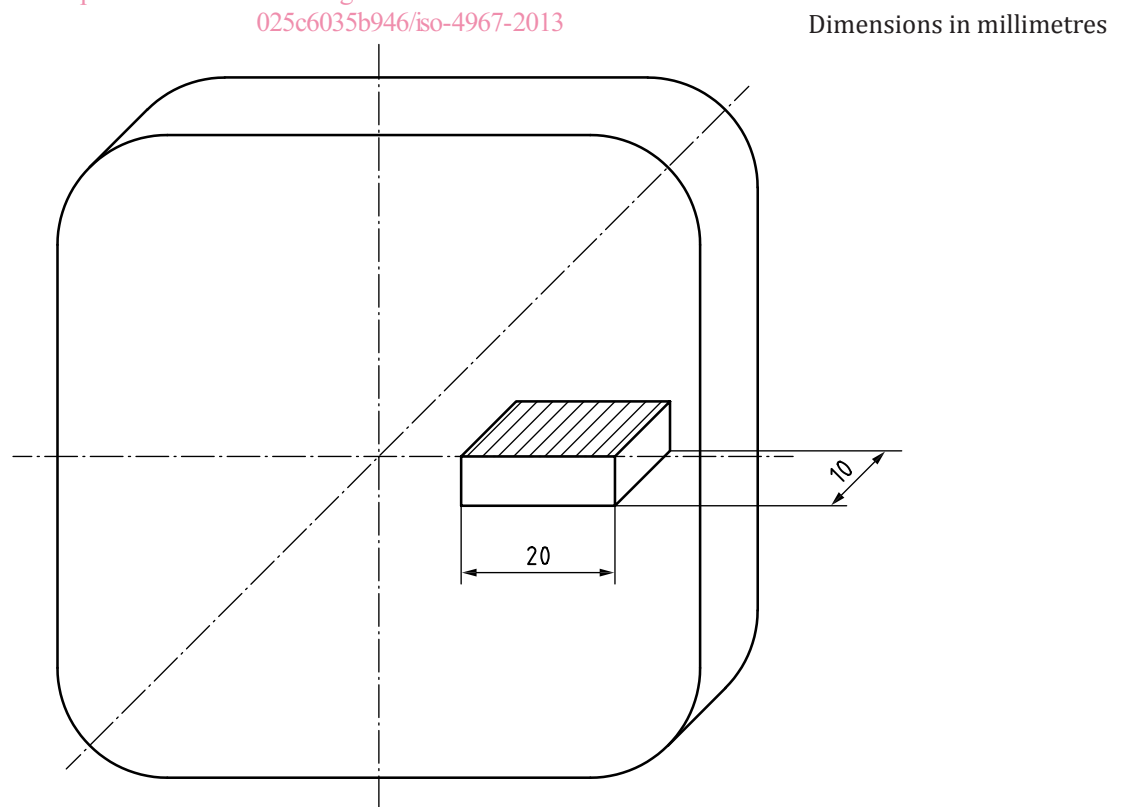

**Figure 1 — Sample from bar or billet with a diameter or length of side > 40 mm**

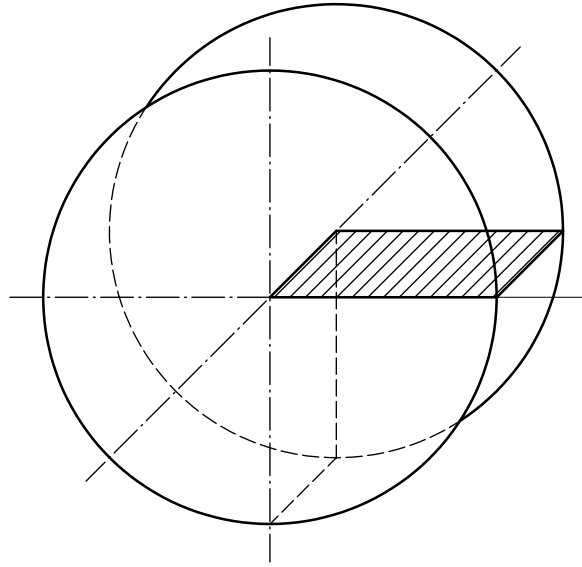

Figure 2 — Sample from bar or billet with a diameter or length of side  $> 25$  mm and  $\leq 40$  mm

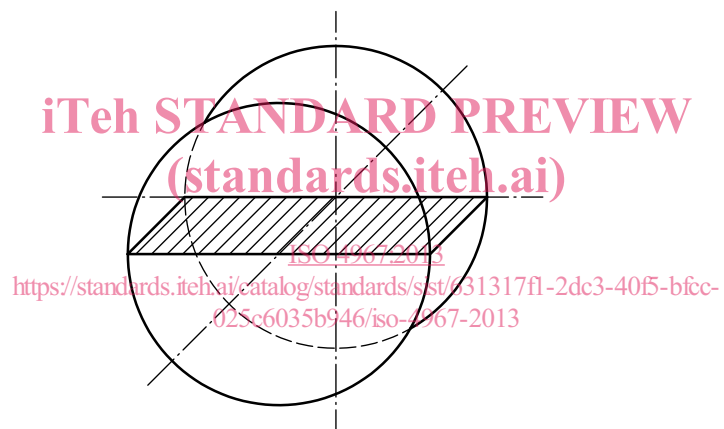
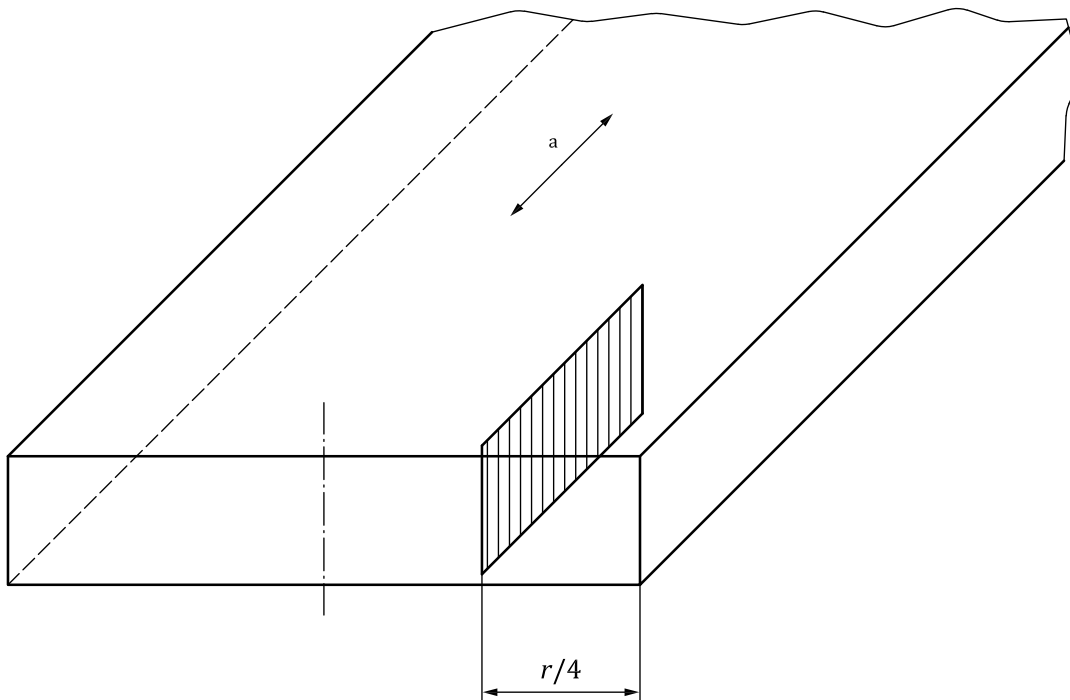

Figure 3 — Sample from bar with a diameter  $\leq 25$  mm





**Key**

- $r$  = width
- $a$  = rolling direction

**iTeh STANDARD PREVIEW**  
(standards.iteh.ai)

**Figure 4 — Sample from plate with thickness  $\leq 25$  mm**

ISO 4967:2013

<https://standards.iteh.ai/catalog/standards/sist/631317f1-2dc3-40f5-bfce-025c6035b946/iso-4967-2013>

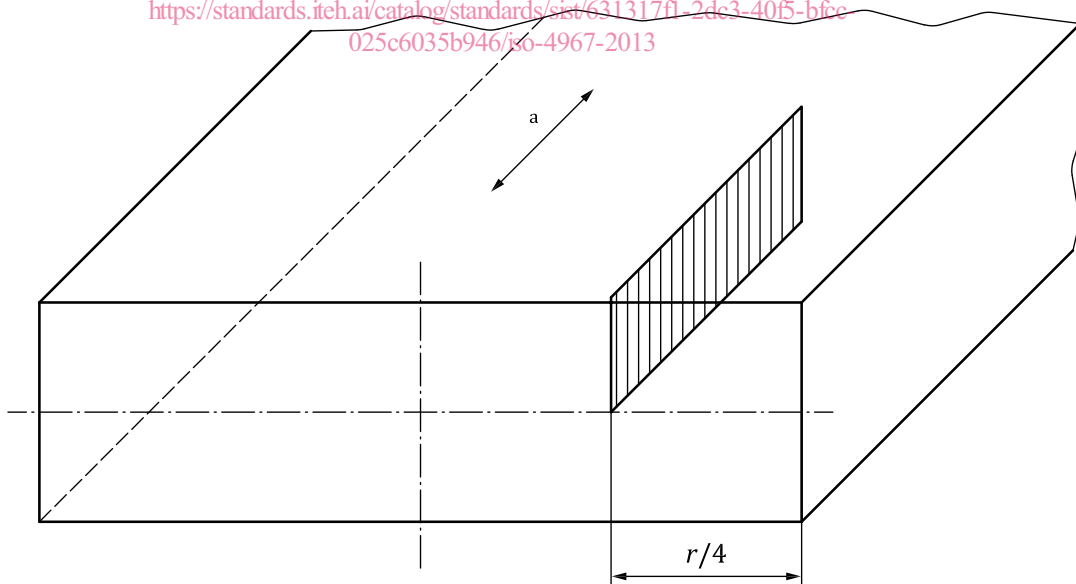

**Key**

- $r$  = width
- $a$  = rolling direction

**Figure 5 — Sample from plate with thickness  $> 25$  mm and  $\leq 50$  mm**

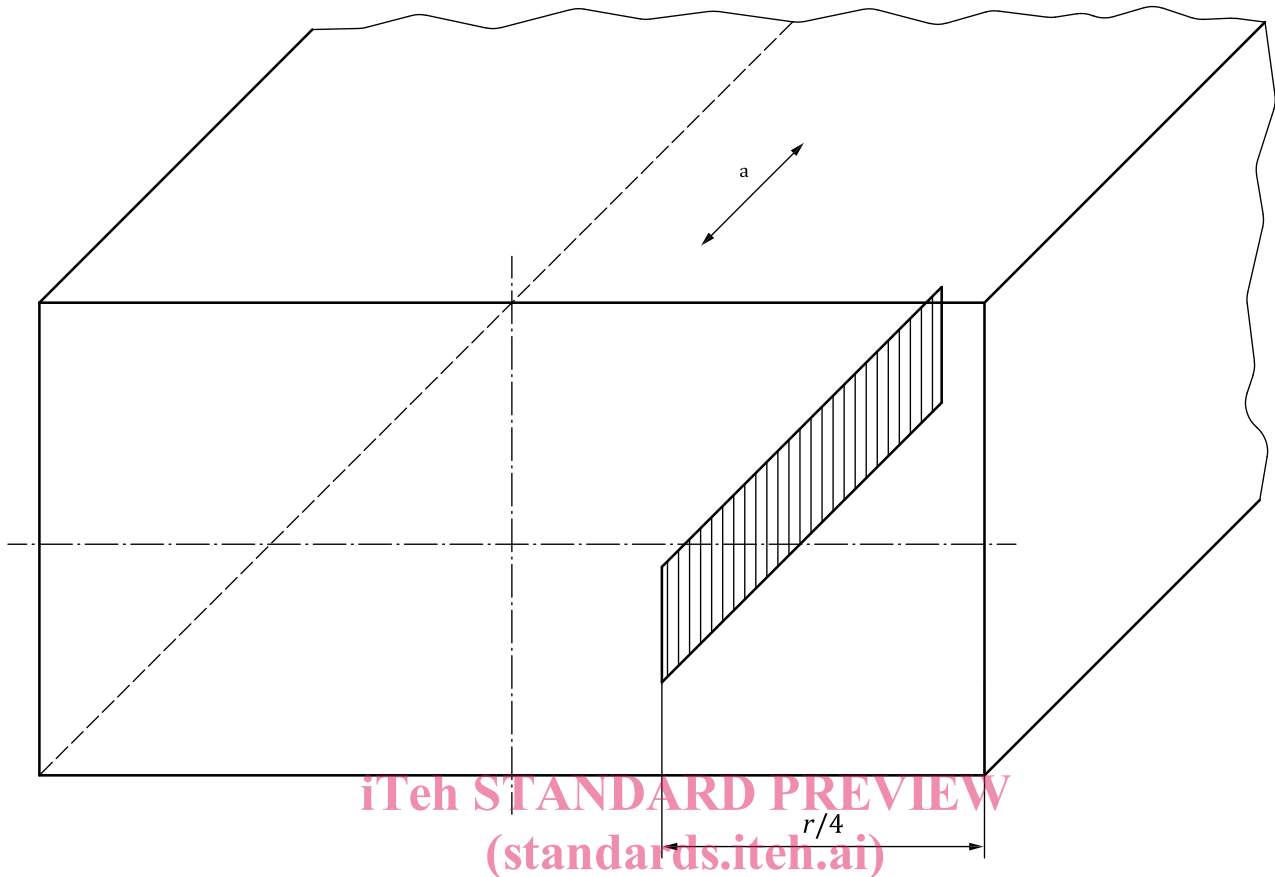

**Key**  
 r = width  
 a = rolling direction

ISO 4967:2013  
<https://standards.iteh.ai/catalog/standards/sist/631317f1-2dc3-40f5-bfcc-025c6035b946/iso-4967-2013>

**Figure 6 — Sample from plate with thickness > 50 mm**

## 4 Preparation of specimens

The specimen shall be cut so as to obtain a surface for examination. In order to achieve a flat surface and to avoid rounding the edges of the specimen when polishing, the specimen may be held mechanically or may be mounted.

When polishing specimens, it is important to avoid any tearing out or deformation of the inclusions, or contamination of the polished surface, so that the surface is as clean as possible and the shape of the inclusions is not affected. These precautions are of particular importance when the inclusions are small. It is advisable to use diamond paste for polishing. In certain cases it may be necessary for the specimen to be heat treated before polishing in order to give it the maximum possible hardness.

## 5 Determination of the content of inclusions

### 5.1 Method of observation

Examination with the microscope may be by one of two methods:

- by projection on to ground glass,
- by observation by means of an eyepiece.

The method of observation chosen shall be maintained throughout the test.

If the image is projected onto a ground glass or similar device, the magnification shall be  $100 \times \pm 2 \times$  on the ground glass. Place a clear plastic overlay (Figure 7) of a 71 mm square ( $0,50 \text{ mm}^2$  true area) over or behind the ground glass projection screen. The image within the test square is compared to the standard pictures on the chart (Annex A).

If the inclusions are examined through the microscope eyepieces, insert a reticle with the test pattern shown in Figure 7 in the microscope at the appropriate location so that the test grid area is  $0,50 \text{ mm}^2$  at the image plane.

NOTE In special cases, a magnification greater than 100 may be used, provided that the same magnification is applied for the standard diagrams, and shall be recorded in the test report.

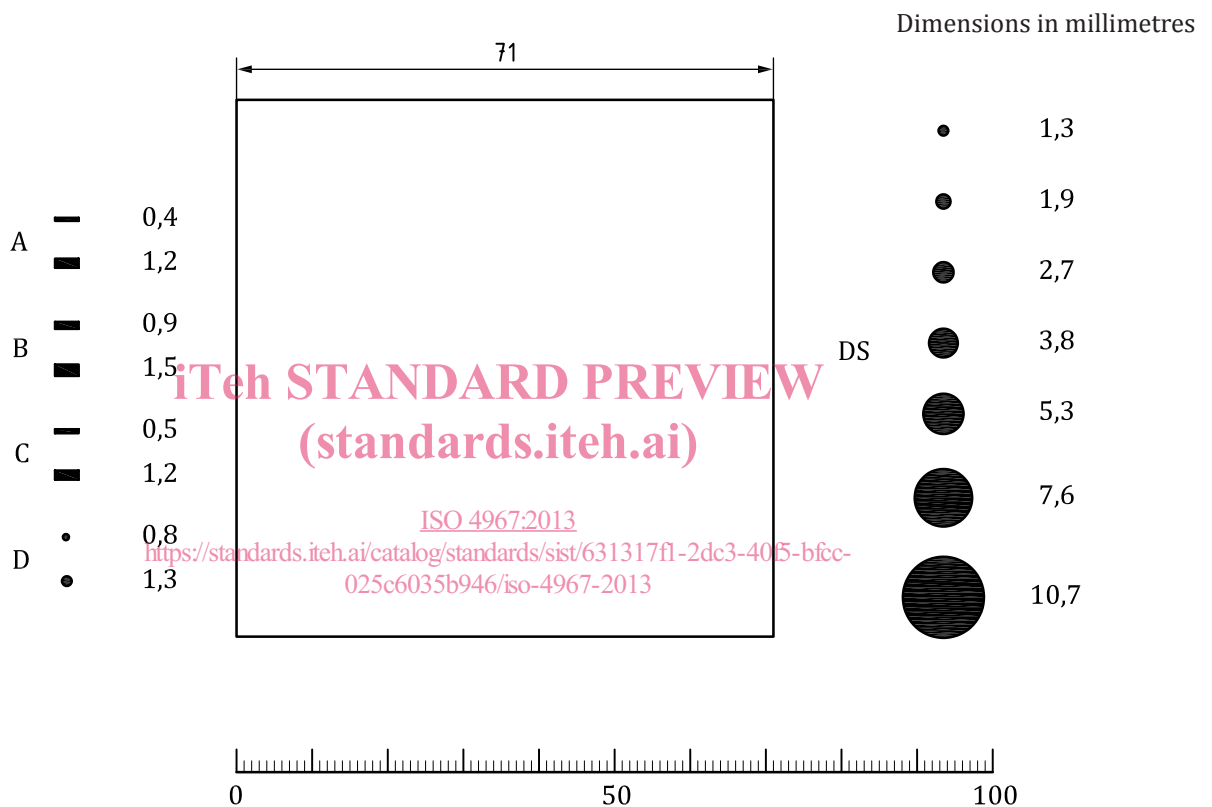

Figure 7 — Test pattern for grid overlays or reticles

## 5.2 Actual examination

Two methods are defined as described in 5.2.1 and 5.2.2.

### 5.2.1 Method A

The entire polished surface is examined and, for each type of inclusion, a note is made of the reference number which lies to the side of the standard diagram which corresponds to the worst field examined, in the fine and thick series.

### 5.2.2 Method B

The entire polished surface is examined and each field of the specimen is compared with the standard diagrams. The reference number of the field (indicated to the side of the standard diagrams) which best corresponds to the field examined for each type of inclusion is noted, in the fine and thick series.

In order to minimize the cost of examination, it may be agreed upon to make a partial examination of the specimen by studying a reduced number of fields, distributed in accordance with a fixed scheme. Both the number of fields examined and their distribution shall be arranged by prior agreement.

**5.2.3 General rules for methods A and B**

Each field observed is compared with the standard diagrams. If a field of inclusions falls between two standard diagrams, it is rated following the lower diagram.

Individual inclusions or stringers that have a length greater than the field width (0,710 mm) or a width or diameter greater than the thick series maximum (see [Table 2](#)) will be rated as oversized by length, width or diameter. The oversized dimensions of the inclusion or stringer shall be noted separately. However, these inclusions shall still be part of the overall rating of that field.

Reproducibility of measurements is improved if actual measurements (stringer lengths of A, B or C types, diameter of DS type) and counts (D types) are made. Use a grid overlay or reticle, as shown in [Figure 7](#), the measurement limits in [Tables 1](#) and [2](#), and the morphological descriptions in [Clause 2](#), as illustrated in the chart.

Non-traditional inclusion types are rated according to the chart group (A, B, C, D, DS) that best corresponds to their morphology. Compare the length, number, thickness or diameter of the inclusions to each group shown in [Annex A](#) or determine their total length, number, thickness or diameter, and use [Tables 1](#) and [2](#) to assign the appropriate inclusion content number and thickness class (fine, thick or oversize). Then indicate the nature of the non-traditional inclusion with a subscript to the group type. Define the subscript in the test report.

For type A, B and C inclusions, two individual inclusions or stringers of lengths  $l_1$  and  $l_2$  and which are, or are not, in line are considered as one inclusion or stringer if the distance  $d$  is lower than or equal to  $40 \mu\text{m}$  and if the distance  $s$ , (the distance between centres of inclusions/stringers) is lower than or equal to  $10 \mu\text{m}$  (see [Figures 8](#) and [9](#)).

In the case of a stringer with inclusions of different width, the width to be considered is the width of the biggest inclusion.

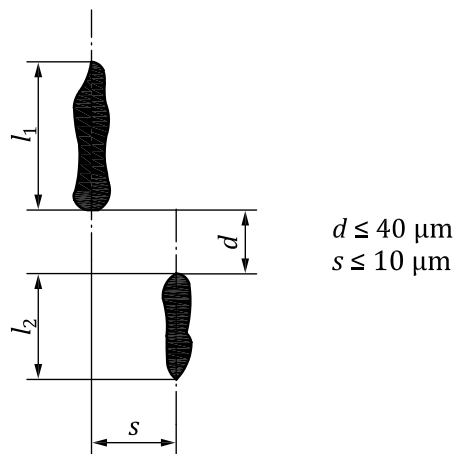

**Figure 8 — Type A and C inclusions**

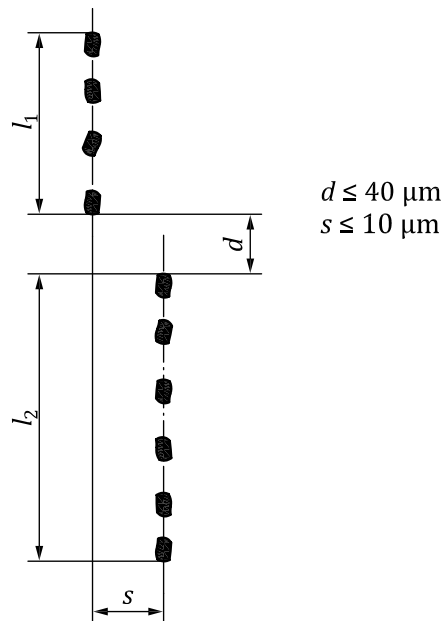

Figure 9 — Type B inclusions

## 6 Expression of results

### 6.1 General

Unless otherwise stated in the product standard, the results may be expressed as described in 6.2 and 6.3 depending on the method used (method A or method B).

### 6.2 Case of method A

For each type of inclusion and for each thickness series (see Annex B), the reference symbol for the group of inclusions shall be followed by the reference number of the worst field, the presence of thick inclusions being indicated by the letter e, the presence of inclusion oversized (see 5.2.3) being indicated by the letter s.

EXAMPLES A 2, B 1e, C 3, D 1, B 2s, DS 0,5.

Any subscripts used to identify non-traditional inclusion types shall be defined.

On the basis of the index numbers relating to each specimen and on their basis, an arithmetic mean may be assessed per cast for each type of inclusion and for each thickness series.

### 6.3 Case of method B

The total number of fields shall be indicated for a given index, per type of inclusion and per thickness series for a given number of fields observed ( $N$ ).

The full set of total numbers of fields for a given index relative to the various types of inclusions may be used in special methods for expressing results, such as total index,  $i_{tot}$ , or mean index,  $i_{moy}$ , subject to agreement between the parties.

EXAMPLE:

For type A inclusions taking

$n_1$  as the number of fields of index 0,5,