**Footwear — Test methods for insoles
— Delamination resistance**

*Chaussures — Méthodes d'essai applicables aux premières de
montage — Résistance au délaminage*

**iTeh STANDARD PREVIEW
(standards.iteh.ai)**

[ISO 20866:2018](https://standards.iteh.ai/catalog/standards/sist/19041fla-2d3a-4a42-a22d-94b915704658/iso-20866-2018)

<https://standards.iteh.ai/catalog/standards/sist/19041fla-2d3a-4a42-a22d-94b915704658/iso-20866-2018>



iTeh STANDARD PREVIEW
(standards.iteh.ai)

ISO 20866:2018

<https://standards.iteh.ai/catalog/standards/sist/19041fla-2d3a-4a42-a22d-94b915704658/iso-20866-2018>



COPYRIGHT PROTECTED DOCUMENT

© ISO 2018

All rights reserved. Unless otherwise specified, or required in the context of its implementation, no part of this publication may be reproduced or utilized otherwise in any form or by any means, electronic or mechanical, including photocopying, or posting on the internet or an intranet, without prior written permission. Permission can be requested from either ISO at the address below or ISO's member body in the country of the requester.

ISO copyright office
CP 401 • Ch. de Blandonnet 8
CH-1214 Vernier, Geneva
Phone: +41 22 749 01 11
Fax: +41 22 749 09 47
Email: copyright@iso.org
Website: www.iso.org

Published in Switzerland

Contents

	Page
Foreword	iv
1 Scope	1
2 Normative references	1
3 Terms and definitions	1
4 Apparatus and material	1
5 Sampling and conditioning	2
6 Test methods	2
7 Expression of results	3
7.1 Dry test	3
7.2 Wet test	3
8 Test report	3

iTeh STANDARD PREVIEW (standards.iteh.ai)

[ISO 20866:2018](https://standards.iteh.ai/catalog/standards/sist/19041f1a-2d3a-4a42-a22d-94b915704658/iso-20866-2018)

<https://standards.iteh.ai/catalog/standards/sist/19041f1a-2d3a-4a42-a22d-94b915704658/iso-20866-2018>

Foreword

ISO (the International Organization for Standardization) is a worldwide federation of national standards bodies (ISO member bodies). The work of preparing International Standards is normally carried out through ISO technical committees. Each member body interested in a subject for which a technical committee has been established has the right to be represented on that committee. International organizations, governmental and non-governmental, in liaison with ISO, also take part in the work. ISO collaborates closely with the International Electrotechnical Commission (IEC) on all matters of electrotechnical standardization.

The procedures used to develop this document and those intended for its further maintenance are described in the ISO/IEC Directives, Part 1. In particular the different approval criteria needed for the different types of ISO documents should be noted. This document was drafted in accordance with the editorial rules of the ISO/IEC Directives, Part 2 (see www.iso.org/directives).

Attention is drawn to the possibility that some of the elements of this document may be the subject of patent rights. ISO shall not be held responsible for identifying any or all such patent rights. Details of any patent rights identified during the development of the document will be in the Introduction and/or on the ISO list of patent declarations received (see www.iso.org/patents).

Any trade name used in this document is information given for the convenience of users and does not constitute an endorsement.

For an explanation on the voluntary nature of standards, the meaning of ISO specific terms and expressions related to conformity assessment, as well as information about ISO's adherence to the World Trade Organization (WTO) principles in the Technical Barriers to Trade (TBT) see the following URL: www.iso.org/iso/foreword.html. (standards.iteh.ai)

This document was prepared by Technical Committee ISO/TC 216, *Footwear*.

This second edition cancels and replaces the first edition (ISO 20866:2001), which has been technically revised.

Footwear — Test methods for insoles — Delamination resistance

1 Scope

This document specifies a test method for the determination of the delamination resistance of insoles, irrespective of the material.

2 Normative references

The following documents are referred to in the text in such a way that some or all of their content constitutes requirements of this document. For dated references, only the edition cited applies. For undated references, the latest edition of the referenced document (including any amendments) applies.

ISO 5893, *Rubber and plastics test equipment — Tensile, flexural and compression types (constant rate of traverse) — Specification*

ISO 17709, *Footwear — Sampling location, preparation and duration of conditioning of samples and test pieces*

ISO 18454, *Footwear — Standard atmospheres for conditioning and testing of footwear and components for footwear*

3 Terms and definitions

ISO 20866:2018

<https://standards.iteh.ai/catalog/standards/sist/19041fla-2d3a-4a42-a22d-4a9101010101>

For the purposes of this document, the following terms and definitions apply.

ISO and IEC maintain terminological databases for use in standardization at the following addresses:

- ISO Online browsing platform: available at <https://www.iso.org/obp>
- IEC Electropedia: available at <http://www.electropedia.org/>

3.1

delamination resistance

force per unit area required to separate the internal structure of the insole material

4 Apparatus and material

The following apparatus and material shall be used.

4.1 Tensile-testing machine (dynamometer), shall comply with the requirements of ISO 5893, to an accuracy corresponding to grade B, with a constant rate of traverse of 25 mm/min ± 5 mm/min.

4.2 Pairs of solid cylinders, each cylinder with a diameter of 38,92 mm ± 0,02 mm, with provisions for attachment to the tensile-testing machine. The end faces of the cylinders shall be at right angles to their axes. The cylinders shall fit in the tensile-testing machine so that the line of action passes through the axis of the two cylinders. One pair of cylinders is required for each test piece.

4.3 Collars, with internal diameters of 39,00 mm ± 0,03 mm, to keep the cylinders and test pieces coaxial during assembly.

4.4 Circular knife, to cut a circular test piece of diameter 38,0 mm ± 1,0 mm. The inner surface of the knife shall be angled outward from the cutting edge at approximately 5° to the vertical so that when the test piece is cut it passes through the knife without damage to the edge of the test piece.

4.5 Press or similar apparatus, capable of exerting a force of 5,00 kN ± 0,25 kN on the assembly of cylinders and test piece.

4.6 Vernier calipers, capable of measuring to an accuracy of 0,1 mm.

4.7 Polymer adhesive, solvent-based, chloroprene rubber type.

NOTE Suitable adhesives are most chloroprene rubber sole-attaching adhesives and commercially available chloroprene rubber impact adhesives sold for household use.

4.8 Distilled water.

5 Sampling and conditioning

Using the circular knife described in 4.4, cut out three test pieces of diameter 38,0 mm ± 1,0 mm, from the shoe insoles, cut insoles or from the component as supplied.

If the test pieces are taken from the shoe insoles or cut insoles, sampling shall be done in accordance with ISO 17709.

Condition the test pieces in accordance with ISO 18454, for a minimum of 24 h.

If a wet test is required cut out three additional test pieces.

iTeh STANDARD PREVIEW
(standards.iteh.ai)

ISO 20866:2018

6 Test methods <https://standards.iteh.ai/catalog/standards/sist/19041fla-2d3a-4a42-a22d-94b915704658/iso-20866-2018>

6.1 Measure the diameter of each test piece to the nearest 0,1 mm with the vernier calipers (4.6). Clean the end faces of the cylinders (4.2) to remove all traces of insole material and adhesive from previous tests and remove all traces of grease.

6.2 Assemble each pair of cylinders with one of the test pieces using the following procedure: Coat the end faces of a pair of cylinders and both surfaces of a test piece with adhesive (4.7), and allow to dry for 20 min. Place the collar (4.3) over the end of one cylinder, place the test piece in the collar and press it lightly on to the cylinder face. Insert the end face of the other cylinder into the collar and press lightly on to test piece.

Place the assembly of cylinders, test piece and collar into the press (4.5), exert a force of 5,00 kN ± 0,25 kN to press the cylinders on to the test piece with the collar in position.

6.3 Remove the collars and leave the test assemblies in the conditioning atmosphere, according to ISO 18454, for 24 h before proceeding further with the determination.

See [Figure 1](#) for an example of device measuring delamination resistance.

6.4 Fit the first test assembly into the tensile-testing machine and run the machine at a cross-head speed giving a cylinder separation speed of 25 mm/min ± 5 mm/min. Record the maximum force obtained.

6.5 Repeat the procedure for the other two test assemblies. Reject the result of any test in which the test piece shows failure of adhesion of the adhesive film either to the insole material or to a cylinder and repeat the procedure on a further test piece.

6.6 For the test specimens that are to be tested wet:

6.6.1 Follow the procedure in [6.1](#) to [6.3](#) to procedure three test assemblies.

6.6.2 Soak the three test assemblies in distilled water ([4.8](#)) for $(6,0 \pm 0,5)$ h.

6.6.3 Remove each test assembly from the water, and immediately carry out the procedure described in [6.4](#) to [6.5](#).

7 Expression of results

7.1 Dry test

Divide the mean of the three maximum recorded forces by the mean of the areas (one surface) of the three test pieces. Express the result, in megapascals¹⁾, as the delamination resistance of the insole material.

7.2 Wet test

Divide the mean of the three maximum recorded forces obtained in the wet test assemblies by the mean of the areas (one surface) of the three test pieces. Express the result in megapascals, as the delamination resistance of the wet insole material.

iTeh STANDARD PREVIEW

8 Test report

(standards.iteh.ai)

The test report shall include the following information:

- a) a reference to this document, i.e. [ISO 20866:2018](#); ISO 20866:2018
https://standards.iteh.ai/standards/ISO/20866:2018/19041fla-2d3a-4a42-a22d-94b915704658/iso-20866-2018
- b) the result, expressed in accordance with [Clause 7](#);
- c) the nature and full identification of the sample;
- d) a description of the sampling procedure, where relevant;
- e) a reference to the method of test (dry or wet test);
- f) details of any deviation from the standard test procedure;
- g) the date of testing;
- h) standard atmospheric conditions observed during the test.

1) 1 Mpa (megapascal) = 1 N/mm².

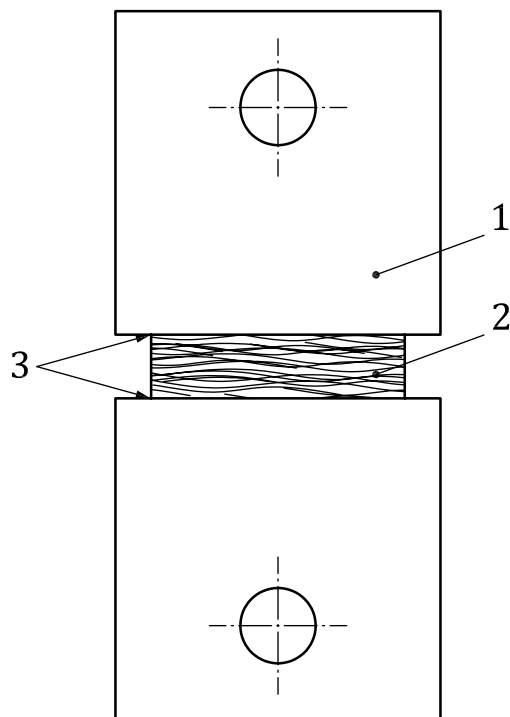

Key

- 1 specimen holder
- 2 test specimen
- 3 cementing assembly

iTeh STANDARD PREVIEW
(standards.iteh.ai)

Figure 1 — Device for measuring delamination resistance
ISO 20866:2018
<https://standards.iteh.ai/catalog/standards/sis/1904111a-2d5a-4a42-a22d-94b915704658/iso-20866-2018>

iTeh STANDARD PREVIEW
(standards.iteh.ai)

ISO 20866:2018

<https://standards.iteh.ai/catalog/standards/sist/19041fa-2d3a-4a42-a22d-94b915704658/iso-20866-2018>