**Traditional Chinese medicine —
Sterile intradermal acupuncture
needles for single use**

*Médecine traditionnelle chinoise — Aiguilles d'acupuncture
intradermiques stériles à usage unique*

**iTeh STANDARD PREVIEW
(standards.iteh.ai)**

[ISO 18746:2016](https://standards.iteh.ai/catalog/standards/sist/b6fc2014-0704-4f72-8e77-098009c738e0/iso-18746-2016)

<https://standards.iteh.ai/catalog/standards/sist/b6fc2014-0704-4f72-8e77-098009c738e0/iso-18746-2016>



iTeh STANDARD PREVIEW
(standards.iteh.ai)

ISO 18746:2016

<https://standards.iteh.ai/catalog/standards/sist/b6fc2014-0704-4f72-8e77-098009c738e0/iso-18746-2016>



COPYRIGHT PROTECTED DOCUMENT

© ISO 2016, Published in Switzerland

All rights reserved. Unless otherwise specified, no part of this publication may be reproduced or utilized otherwise in any form or by any means, electronic or mechanical, including photocopying, or posting on the internet or an intranet, without prior written permission. Permission can be requested from either ISO at the address below or ISO's member body in the country of the requester.

ISO copyright office
Ch. de Blandonnet 8 • CP 401
CH-1214 Vernier, Geneva, Switzerland
Tel. +41 22 749 01 11
Fax +41 22 749 09 47
copyright@iso.org
www.iso.org

Contents

Page

Foreword	iv
Introduction	v
1 Scope	1
2 Normative references	1
3 Terms and definitions	1
4 Structure and dimension of intradermal acupuncture needles	2
4.1 Size designation.....	2
4.2 Structure and dimension of intradermal granule type needle.....	3
4.2.1 Structure of intradermal granule type needle.....	3
4.2.2 Dimension of intradermal granule type needle.....	3
4.3 Structure and dimension of intradermal thumbtack type needle.....	4
4.3.1 Structure of intradermal thumbtack type needle.....	4
4.3.2 Dimension of intradermal thumbtack type needle.....	4
5 Materials	5
5.1 General.....	5
5.2 Body of intradermal acupuncture needle.....	5
6 Performance requirements	5
6.1 Appearance and cleanliness.....	5
6.2 Drawing strength.....	5
6.3 Hardness of the needle body.....	6
6.4 Intensity and puncture performance of the needle tip.....	6
6.5 Sterility.....	6
7 Packing and identification	6
7.1 Primary packaging.....	6
7.1.1 Packing method.....	6
7.1.2 Identification.....	6
7.2 Secondary packaging.....	7
7.2.1 Packing method.....	7
7.2.2 Identification.....	7
Bibliography	8

Foreword

ISO (the International Organization for Standardization) is a worldwide federation of national standards bodies (ISO member bodies). The work of preparing International Standards is normally carried out through ISO technical committees. Each member body interested in a subject for which a technical committee has been established has the right to be represented on that committee. International organizations, governmental and non-governmental, in liaison with ISO, also take part in the work. ISO collaborates closely with the International Electrotechnical Commission (IEC) on all matters of electrotechnical standardization.

The procedures used to develop this document and those intended for its further maintenance are described in the ISO/IEC Directives, Part 1. In particular the different approval criteria needed for the different types of ISO documents should be noted. This document was drafted in accordance with the editorial rules of the ISO/IEC Directives, Part 2 (see www.iso.org/directives).

Attention is drawn to the possibility that some of the elements of this document may be the subject of patent rights. ISO shall not be held responsible for identifying any or all such patent rights. Details of any patent rights identified during the development of the document will be in the Introduction and/or on the ISO list of patent declarations received (see www.iso.org/patents).

Any trade name used in this document is information given for the convenience of users and does not constitute an endorsement.

For an explanation on the meaning of ISO specific terms and expressions related to conformity assessment, as well as information about ISO's adherence to the World Trade Organization (WTO) principles in the Technical Barriers to Trade (TBT) see the following URL: www.iso.org/iso/foreword.html.

The committee responsible for this document is ISO/TC 249, *Traditional Chinese medicine*.

ISO 18746:2016

<https://standards.iteh.ai/catalog/standards/sist/b6fc2014-0704-4f72-8e77-098009c738e0/iso-18746-2016>

Introduction

As one of several different needling approaches, intradermal acupuncture needles are recognized as an effective treatment for various disorders. Intradermal acupuncture needles are easy to use and especially effective when relatively long-lasting stimulation to a needling site is needed. Therefore, safety and sanitation considerations of intradermal acupuncture needles should be more carefully reviewed as well as their compatibility to human body.

As a biomaterial, acupuncture needles can be corrosive and have potential to lose some of their mechanical characteristics. Furthermore, leachable substances can affect human tissue in any unintended, yet potentially harmful way. To address this problem, biomaterials should have no toxicity or produce any adverse effects, and should have appropriate mechanical characteristics such as tensile strength, elasticity, durability of abrasion and fatigue strength. In addition, the material should have a strong corrosion resistant ability.

This International Standard establishes an international standard for intradermal acupuncture needles. The characteristics of intradermal acupuncture needles include size, material, quality, tests, packing and identification through regulating marking methods. The standardization of the characteristics of intradermal acupuncture needles has potential to enhance the efficacy and improve the quality and safety of acupuncture treatments using intradermal acupuncture needles especially in regard to the biocompatibility for human body.

iTeh STANDARD PREVIEW (standards.iteh.ai)

[ISO 18746:2016](https://standards.iteh.ai/catalog/standards/sist/b6fc2014-0704-4f72-8e77-098009c738e0/iso-18746-2016)

<https://standards.iteh.ai/catalog/standards/sist/b6fc2014-0704-4f72-8e77-098009c738e0/iso-18746-2016>

iTeh STANDARD PREVIEW
(standards.iteh.ai)

ISO 18746:2016

<https://standards.iteh.ai/catalog/standards/sist/b6fc2014-0704-4f72-8e77-098009c738e0/iso-18746-2016>

Traditional Chinese medicine — Sterile intradermal acupuncture needles for single use

1 Scope

This International Standard specifies the requirements of sterile intradermal acupuncture needle for single use as a medical device, including the following factors:

- a) size;
- b) material;
- c) quality;
- d) testing methods;
- e) packing;
- f) identification.

2 Normative references

The following documents, in whole or in part, are normatively referenced in this document and are indispensable for its application. For dated references, only the edition cited applies. For undated references, the latest edition of the referenced document (including any amendments) applies.

ISO 10993-1, *Biological evaluation of medical devices — Part 1: Evaluation and testing within a risk management process*

ISO 10993-7, *Biological evaluation of medical devices — Part 7: Ethylene oxide sterilization residuals*

ISO 15223-1, *Medical devices — Symbols to be used with medical device labels, labelling and information to be supplied — Part 1: General requirements*

ISO 17218:2014, *Sterile acupuncture needles for single use*

3 Terms and definitions

For the purposes of this document, the following terms and definitions apply.

3.1

intradermal acupuncture needles

small needling instrument for embedding in the skin

Note 1 to entry: There are two types of intradermal acupuncture needles. One is termed an intradermal thumbtack type needle and the other is intradermal granule type needle.

[SOURCE: WHO International Standard Terminologies on Traditional Medicine in the Western Pacific Region, 5.1.29, modified — Note 1 to entry has been added.]

3.2

intradermal granule type needle

intradermal acupuncture needle inserted obliquely or horizontally into subcutaneous tissue often across various sites on the human body

3.3

intra-dermal thumbtack type needle

intra-dermal acupuncture needle resembling a thumbtack

[SOURCE: WHO International Standard Terminologies on Traditional Medicine in the Western Pacific Region, 5.1.28]

3.4

body of the needle

part of the intra-dermal acupuncture needle that is inserted into the human body

[SOURCE: ISO 17218:2014, 3.1, modified]

3.5

handle of the needle

part of the intra-dermal acupuncture needle that is not inserted into the human body and is often used to manipulate the needle during insertion

[SOURCE: ISO 17218:2014, 3.2, modified]

3.6

tip of the needle

sharp apex at the end of the acupuncture needle body that is inserted into the human body

[SOURCE: ISO 17218:2014, 3.3]

3.7

primary package

sealed or closed packaging system that forms a microbial barrier, directly enclosing the acupuncture needle

[SOURCE: ISO 17218:2014, 3.9]

iTeh STANDARD PREVIEW
(standards.iteh.ai)

ISO 18746:2016
<https://standards.iteh.ai/catalog/standards/sist/b6fc2014-0704-4f72-8e77-098009c738e0/iso-18746-2016>

3.8

secondary package

package containing one or more primary packages for transportation and storage

[SOURCE: ISO 17218:2014, 3.10, modified]

4 Structure and dimension of intra-dermal acupuncture needles

4.1 Size designation

The size of the body of the needle shall be designated by the following:

- a) the nominal diameter of the body of the needle (or when no body of the needle, the maximum diameter of the tip of the needle), expressed in millimetres;
- b) the nominal length of the body of the needle, expressed in millimetres.

The size shall be referred to as “the designated metric size” and specified as a) × b).

EXAMPLE Ø 0,16 mm × 10 mm.

4.2 Structure and dimension of intradermal granule type needle

4.2.1 Structure of intradermal granule type needle

The intradermal granule type needle shall have the structure as shown in [Figure 1](#) and be composed of the body of the needle, the handle of the needle and the tape (in some cases). The type of needle handles are not limited to those shown in [Figure 1](#).

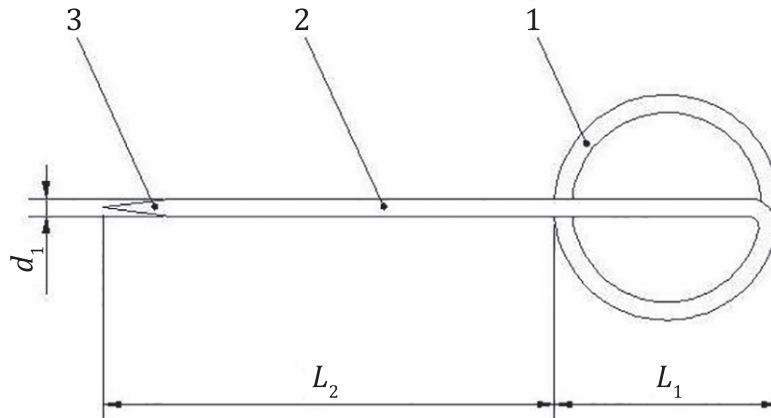

Key

- | | | | |
|---|----------------------|-------|--------------------------------|
| 1 | handle of the needle | d_1 | diameter of body of the needle |
| 2 | body of the needle | L_1 | length of handle of the needle |
| 3 | tip of the needle | L_2 | length of body of the needle |

Figure 1 — Example of typical structure of intradermal granule type needle
 ISO 18746:2016
<https://standards.iteh.ai/catalog/standards/sis/601c2014-0704-4172-8c77-098009c738e0/iso-18746-2016>

4.2.2 Dimension of intradermal granule type needle

The nominal diameter of body of the needle and the length of body and handle of the needle shall be measured using a gauge specified in [Table 1](#) (see [Figure 1](#)).

Table 1 — Nominal dimension of intradermal granule type needle

Part		Nominal dimensions mm	Tolerance
The body of the needle	Nominal diameter d_1	$d < 0,40$	$\pm 10 \%$
	Nominal length L_2	$L_2 < 5$	$\pm 0,5$
		$5 \leq L_2 < 10$	$\pm 0,8$
		$10 \leq L_2 \leq 30$	$\pm 1,0$
The handle of the needle	Nominal length L_1	$1,6 \leq L_1$	