



Designation: D2266 – 01(Reapproved 2008)

Standard Test Method for Wear Preventive Characteristics of Lubricating Grease (Four-Ball Method)¹

This standard is issued under the fixed designation D2266; the number immediately following the designation indicates the year of original adoption or, in the case of revision, the year of last revision. A number in parentheses indicates the year of last reapproval. A superscript epsilon (ϵ) indicates an editorial change since the last revision or reapproval.

This standard has been approved for use by agencies of the Department of Defense.

1. Scope

1.1 This test method covers the determination of the wear preventive characteristics of greases in sliding steel-on-steel applications. It is not intended to predict wear characteristics with metal combinations other than steel-on-steel or to evaluate the extreme pressure characteristics of the grease.

1.2 The values stated in SI units are to be regarded as the standard except where the test apparatus or consumable parts are only available in other units. In such cases, these will be regarded as standard. The values given in parentheses are for information only.

1.3 *This standard does not purport to address all of the safety problems, if any, associated with its use. It is the responsibility of the user of this standard to establish appropriate safety and health practices and determine the applicability of regulatory limitations prior to use.*

2. Referenced Documents

2.1 *ASTM Standards:*²

[D4172 Test Method for Wear Preventive Characteristics of Lubricating Fluid \(Four-Ball Method\)](#)

[D6300 Practice for Determination of Precision and Bias](#)

¹This test method is under the jurisdiction of ASTM Committee D02 on Petroleum Products and Lubricants and is the direct responsibility of Subcommittee D02.G0.04 on Functional Tests - Tribology.

Current edition approved May 1, 2008. Published September 2008. Originally approved in 1964. Last previous edition approved in 2001 as D2266-01.

This test method has been adopted for use by government agencies to replace Method 6514 of Federal Test Method Standard No. 791b. DOI: 10.1520/D2266-01R08.

²For referenced ASTM standards, visit the ASTM website, www.astm.org, or contact ASTM Customer Service at service@astm.org. For *Annual Book of ASTM Standards* volume information, refer to the standard's Document Summary page on the ASTM website.

[Data for Use in Test Methods for Petroleum Products and Lubricants](#)

2.2 *ANSI Standard:*³

[B3.12 for Metal Balls](#)

3. Terminology

3.1 There are no terms in this test method that require new or other than dictionary definitions.

4. Summary of Test Method

4.1 Three ½ in. (12.7-mm) diameter steel balls are clamped together and covered with the lubricant to be evaluated. A fourth ½ in. diameter steel ball, referred to as the top ball, is pressed with a force of 40 kgf (392 N) into the cavity formed by the three clamped balls for three-point contact. The temperature of the lubricating grease specimen is regulated at 75°C (167°F) and then the top ball is rotated at 1200 rpm for 60 min. Lubricants are compared by using the average size of the scar diameters worn on the three lower clamped balls.

NOTE 1—Because of differences in the construction of the various machines on which the four-ball test can be made, the manufacturer's instructions should be consulted for proper machine setup and operation.

NOTE 2—Although the test can be run under other test parameters, the precision noted in Section 11 can vary when testing with other than test parameters listed in Section 8.

5. Significance and Use

5.1 The four-ball wear-test method can be used to determine the relative wear-preventing properties of greases under the test conditions and if the test conditions are changed the relative ratings may be different. No correlation has been established between the four-ball wear test and field service. The test

³ Available from American National Standards Institute (ANSI), 25 W. 43rd St., 4th Floor, New York, NY 10036, <http://www.ansi.org>.

method cannot be used to differentiate between Extreme Pressure (EP) and Non-Extreme Pressure (Non-EP) Greases.⁴

6. Apparatus

6.1 *Four-Ball Wear-Tester and Accessories*—See Fig. 1 and Fig. 2.⁵

NOTE 3—It is important to distinguish between the Four-Ball EP Tester and the Four-Ball Wear Tester. The Four-Ball EP Tester is designed for testing under heavier loads and more severe conditions; it lacks the sensitivity necessary for performing four-ball wear test.

6.2 *Microscope*,⁶ capable of measuring the diameters of the scars produced on the three stationary balls to an accuracy of 0.01 mm. It is more efficient to measure the scars without removing the three balls from the holder.

7. Reagents and Materials

7.1 *Test Balls*⁷, chrome alloy steel, made from AISI standard steel No. E-52100, with diameter of 0.5 in. (12.7 mm), Grade

⁴ Further details on this test method may be found in the article by Stalling, L., *NLGI Spokesman*, Vol 31, No. 11, February 1988, pp. 396–401. This article has been submitted as a research report, but it does not follow research report guidelines because the work was conducted before research report guidelines were instituted.

⁵ The sole source of supply of the Four-Ball Wear Test Machine known to the committee at this time is Falex Corp., 1020 Airpark Drive, Sugar Grove, IL 60554. If you are aware of alternative suppliers, please provide this information to ASTM International Headquarters. Your comments will receive careful consideration at a meeting of the responsible technical committee,¹ which you may attend.

This company can also furnish a microscope with a special base to measure the wear scars without removing the balls from the test-oil cup. Discontinued models of the Four-Ball Wear Test Machine made by Precision Scientific Co. and Roxanna Machine Works are also satisfactory.

⁶ The sole source of supply of the microscope known to the committee at this time is Falex Corp., 1020 Airpark Drive, Sugar Grove, IL 60554. If you are aware of alternative suppliers, please provide this information to ASTM International Headquarters. Your comments will receive careful consideration at a meeting of the responsible technical committee,¹ which you may attend.

Falex Corp. Microscope F-1519-31 measures directly to 0.1 mm and by interpolation to 0.01 mm. A higher resolution version, F-1519-31A, measures to 0.001 mm.

⁷ Steel balls meeting this description were used in developing the precision of the test. They are available from the manufacturer of the test machine and some ball manufacturers. Some operators prefer to check a new box of balls by running an oil or a lubricating grease with a known reference. All balls used in one test should be taken from one carton (of 500 balls) as received from the supplier.

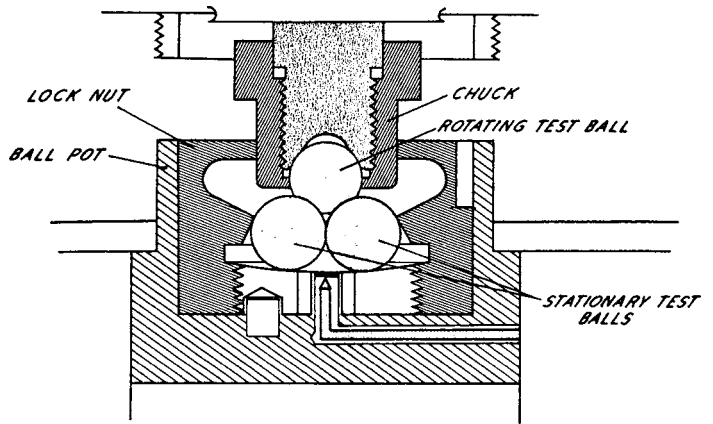

FIG. 2 Falex Corporation (Roxanna) Four-Ball Test Arrangement

25 EP (Extra Polish). Such balls are described in B3.12, for Metal Balls. The Extra-Polish finish is not described in that specification. The Rockwell C hardness shall be 64 to 66, a closer limit than is found in the ANSI requirement.

NOTE 4—Steel balls meeting this description were used in developing the precision of the test.

7.2 *Cleaning Fluids* for preparing balls and apparatus for the test should be those capable of removing metal preservative coating from the balls, eliminating carryover effects from one test to the next. The cleaning fluid selected should be non-film-forming and not contribute to the wear or antiwear properties of the test lubricant. (for example, chlorinated solvents should not be used.)

8. Test Conditions

8.1 The test shall be conducted under the following conditions:

| | |
|-------------|--------------------------|
| Temperature | 75 ± 2°C (167 ± 4°F) |
| Speed | 1200 ± 60 rpm |
| Duration | 60 ± 1 min |
| Load | 40 ± 0.2 kgf (392 ± 2 N) |

NOTE 5—Although the test can be run under other conditions, the precision limits described in Section 11 apply only to tests conducted under the conditions described in Section 8.

9. Preparation of Apparatus

9.1 Set up the drive of the test machine to obtain a spindle speed of 1200 ± 60 rpm.

9.2 Set the temperature controller to maintain a test temperature of 75 ± 2°C (167 ± 4°F).

9.3 When an automatic timer is used to terminate a test, it should be checked for the required ± 1 min. accuracy at 60 min. elapsed time.

9.4 The loading mechanism must be balanced to a zero reading with all parts and test grease in place. To demonstrate proper precision, an addition or subtraction of 0.2 kgf (19.6 N) should be detectable in imbalance. Determination of accuracy of loading at 40 kgf (392 N) is difficult and generally is limited to careful measurement of lever-arm ratios and weights with dead-weight loading apparatus or piston diameter and calibration of pressure gauge with pneumatic loading systems.

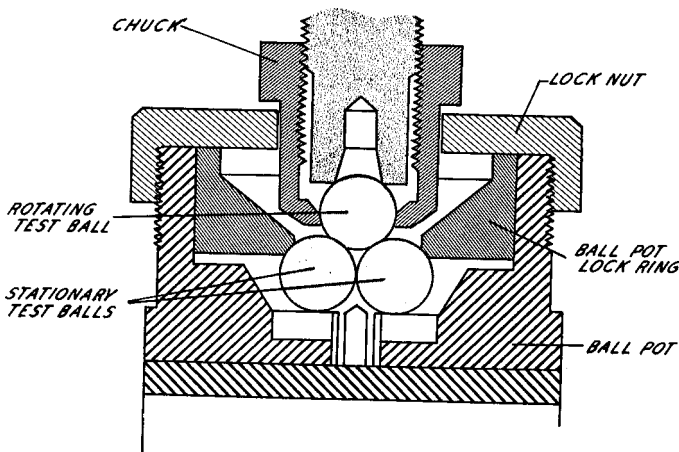

FIG. 1 Precision Scientific Company Four-Ball Test Arrangement