



Designation: ~~C1499-05~~ Designation: C 1499 – 08

Standard Test Method for Monotonic Equibiaxial Flexural Strength of Advanced Ceramics at Ambient Temperature¹

This standard is issued under the fixed designation C 1499; the number immediately following the designation indicates the year of original adoption or, in the case of revision, the year of last revision. A number in parentheses indicates the year of last reapproval. A superscript epsilon (ϵ) indicates an editorial change since the last revision or reapproval.

1. Scope

1.1 This test method covers the determination of the equibiaxial strength of advanced ceramics at ambient temperature via concentric ring configurations under monotonic uniaxial loading. In addition, test specimen fabrication methods, testing modes, testing rates, allowable deflection, and data collection and reporting procedures are addressed. Two types of test specimens are considered: machined test specimens and as-fired test specimens exhibiting a limited degree of warpage. Strength as used in this test method refers to the maximum strength obtained under monotonic application of load. Monotonic loading refers to a test conducted at a constant rate in a continuous fashion, with no reversals from test initiation to final fracture.

1.2 This test method is intended primarily for use with advanced ceramics that macroscopically exhibit isotropic, homogeneous, continuous behavior. While this test method is intended for use on monolithic advanced ceramics, certain whisker- or particle-reinforced composite ceramics as well as certain discontinuous fiber-reinforced composite ceramics may also meet these macroscopic behavior assumptions. Generally, continuous fiber ceramic composites do not macroscopically exhibit isotropic, homogeneous, continuous behavior, and the application of this test method to these materials is not recommended.

~~1.3 Values expressed in this test method are in accordance with the International System of Units (SI) and Practice E380.~~

1.3 The values stated in SI units are to be regarded as standard. No other units of measurement are included in this standard.

1.4 This standard does not purport to address all of the safety concerns, if any, associated with its use. It is the responsibility of the user of this standard to establish appropriate safety and health practices and determine the applicability of regulatory limitations prior to use.

2. Referenced Documents

2.1 *ASTM Standards:*²

C 1145 Terminology of Advanced Ceramics

C 1239 Practice for Reporting Uniaxial Strength Data and Estimating Weibull Distribution Parameters for Advanced Ceramics

C 1259 Test Method for Dynamic Young's Modulus, Shear Modulus, and Poisson's Ratio for Advanced Ceramics by Impulse Excitation of Vibration

C 1322 Practice for Fractography and Characterization of Fracture Origins in Advanced Ceramics

E 4 Practices for Force Verification of Testing Machines

E 6 Terminology Relating to Methods of Mechanical Testing

~~E 83 Practice for Verification and Classification of Extensometer System~~ Practice for Verification and Classification of Extensometer Systems

E 337 Test Method for Measuring Humidity with a Psychrometer (the Measurement of Wet- and Dry-Bulb Temperatures)
~~E380 Practice for Use of International System of Units (SI) (The Modernized Metric System)~~

~~F 394 Test Method for Iron in Trace Quantities Using the 1,10-Phenanthroline Method~~ Test Method for Biaxial Flexure Strength (Modulus of Rupture) of Ceramic Substrates (Discontinued 2001)

IEEE/ASTM SI 10 Standard for Use of the International System of Units (SI): The Modern Metric System

3. Terminology

3.1 *Definitions*—The definitions of terms relating to biaxial testing appearing in Terminology E 6 and Terminology C 1145 may apply to the terms used in this test method. Pertinent definitions are listed below with the appropriate source given in parentheses. Additional terms used in conjunction with this test method are defined in the following section.

¹ This test method is under the jurisdiction of ASTM Committee C28 on Advanced Ceramics and is the direct responsibility of Subcommittee C28.01 on Mechanical Properties and Performance.

Current edition approved ~~June~~ Aug. 1, 2005; ~~2008~~. Published ~~June 2005~~; September 2008. Originally approved in 2001. Last previous edition approved in ~~2004~~ 2005 as C 1499 – 04~~5~~.

² For referenced ASTM standards, visit the ASTM website, www.astm.org, or contact ASTM Customer Service at service@astm.org. For *Annual Book of ASTM Standards* volume information, refer to the standard's Document Summary page on the ASTM website.

3.1.1 *advanced ceramic, n*—highly engineered, high performance predominately non-metallic, inorganic, ceramic material having specific functional attributes. **C 1145**

3.1.2 *breaking load, [F], n*—load at which fracture occurs. **E 6**

3.1.3 *equibiaxial flexural strength, [F/L₂], n*—maximum stress that a material is capable of sustaining when subjected to flexure between two concentric rings. This mode of flexure is a cupping of the circular plate caused by loading at the inner load ring and outer support ring. The equibiaxial flexural strength is calculated from the maximum-load of a biaxial test carried to rupture, the original dimensions of the test specimen, and Poisson's ratio.

3.1.4 *homogeneous, n*—condition of a material in which the relevant properties (composition, structure, density, etc.) are uniform, so that any smaller sample taken from an original body is representative of the whole. Practically, as long as the geometrical dimensions of a sample are large with respect to the size of the individual grains, crystals, components, pores, or microcracks, the sample can be considered homogeneous.

3.1.5 *modulus of elasticity, [F/L₂], n*—ratio of stress to corresponding strain below the proportional limit. **E 6**

3.1.6 *Poisson's ratio, n*—negative value of the ratio of transverse strain to the corresponding axial strain resulting from uniformly distributed axial stress below the proportional limit of the material.

4. Significance and Use

4.1 This test method may be used for material development, material comparison, quality assurance, characterization and design code or model verification.

4.2 Engineering applications of ceramics frequently involve biaxial tensile stresses. Generally, the resistance to equibiaxial flexure is the measure of the least flexural strength of a monolithic advanced ceramic. The equibiaxial flexural strength distributions of ceramics are probabilistic and can be described by a weakest link failure theory, **(1, 2)**³. Therefore, a sufficient number of test specimens at each testing condition is required for statistical estimation or the equibiaxial strength.

4.3 Equibiaxial strength tests provide information on the strength and deformation of materials under multiple tensile stresses. Multiaxial stress states are required to effectively evaluate failure theories applicable to component design, and to efficiently sample surfaces that may exhibit anisotropic flaw distributions. Equibiaxial tests also minimize the effects of test specimen edge preparation as compared to uniaxial tests because the generated stresses are lowest at the test specimen edges.

4.4 The test results of equibiaxial test specimens fabricated to standardized dimensions from a particular material and/or selected portions of a component may not totally represent the strength properties in the entire, full-size component or its in-service behavior in different environments.

4.5 For quality control purposes, results derived from standardized equibiaxial test specimens may be considered indicative of the response of the bulk material from which they were taken for any given primary processing conditions and post-processing heat treatments or exposures.

5. Interferences

ASTM C1499-08

5.1 Test environment (vacuum, inert gas, ambient air, etc.) including moisture content (for example, relative humidity) may have an influence on the measured equibiaxial strength. Testing to evaluate the maximum strength potential of a material can be conducted in inert environments and/or at sufficiently rapid testing rates so as to minimize any environmental effects. Conversely, testing can be conducted in environments, test modes and test rates representative of service conditions to evaluate material performance under use conditions.

5.2 Fabrication of test specimens can introduce dimensional variations that may have pronounced effects on the measured equibiaxial mechanical properties and behavior (for example, shape and level of the resulting stress-strain curve, equibiaxial strength, failure location, etc.). Surface preparation can also lead to the introduction of residual stresses and final machining steps might or might not negate machining damage introduced during the initial machining. Therefore, as universal or standardized methods of surface preparation do not exist, the test specimen fabrication history should be reported. In addition, the nature of fabrication used for certain advanced ceramic components may require testing of specimens with surfaces in the as-fabricated condition (that is, it may not be possible, desired or required to machine some of the test specimen surfaces directly in contact with the test fixture). For very rough or wavy as-fabricated surfaces, perturbations in the stress state due to non-symmetric cross-sections as well as variations in the cross-sectional dimensions may also interfere with the equibiaxial strength measurement. Finally, close geometric tolerances, particularly in regard to flatness of test specimen surfaces in contact with the test fixture components are critical requirements for successful equibiaxial tests. In some cases it may be appropriate to use other test methods (for example, Test Method F 394).

5.3 Contact and frictional stresses in equibiaxial tests can introduce localized failure not representative of the equibiaxial strength under ideal loading conditions. These effects may result in either over or under estimates of the actual strength **(1, 3)**.

5.4 Fractures that consistently initiate near or just outside the load-ring may be due to factors such as friction or contact stresses introduced by the load fixtures, or via misalignment of the test specimen rings. Such fractures will normally constitute invalid tests

³ Withdrawn.

³ The boldface numbers in parentheses refer to the list of references at the end of this standard.

(see Note 14). Splitting of the test specimen along a diameter that expresses the characteristic size may result from poor test specimen preparation (for example, severe grinding or very poor edge preparation), excessive tangential stresses at the test specimen edges, or a very weak material. Such fractures will constitute invalid tests if failure occurred from the edge.

5.5 Deflections greater than one-quarter of the test specimen thickness can result in nonlinear behavior and stresses not accounted for by simple plate theory.

5.6 Warpage of the test specimen can result in nonuniform loading and contact stresses that result in incorrect estimates of the test specimen's actual equibiaxial strength. The test specimen shall meet the flatness requirements (see 8.2 and 8.3) or be specifically noted as warped and considered as a censored test.

6. Apparatus

6.1 *Testing Machines*—Machines used for equibiaxial testing shall conform to the requirements of Practices E 4. The load cells used in determining equibiaxial strength shall be accurate within $\pm 1\%$ at any load within the selected load range of the testing machine as defined in Practice E 4. Check that the expected breaking load for the desired test specimen geometry and test material is within the capacity of the test machine and load cell. Advanced ceramic equibiaxial test specimens require greater loads to fracture than those usually encountered in uniaxial flexure of test specimens with similar cross sectional dimensions.

6.2 *Loading Fixtures for Concentric Ring Testing*—An assembly drawing of a fixture and a test specimen is shown in Fig. 1, and the geometries of the load and support rings are given in Fig. 2.

6.2.1 *Loading Rods and Platens*—Surfaces of the support platen shall be flat and parallel to 0.05 mm. The face of the load rod in contact with the support platen shall be flat to 0.025 mm. In addition, the two loading rods shall be parallel to 0.05 mm per 25 mm length and concentric to 0.25 mm when installed in the test machine.

6.2.2 *Loading Fixture and Ring Geometry*— Ideally, the bases of the load and support fixtures should have the same outer diameter as the test specimen for ease of alignment. Parallelism and flatness of faces as well as concentricity of the load and support rings shall be as given in Fig. 2. The ratio of the load ring diameter, D_L , to that of the support ring, D_S , shall be $0.2 \leq D_L/D_S \leq 0.5$. For test materials exhibiting low elastic modulus ($E < 100$ GPa) and high strength ($\sigma_f > 1$ GPa) it is recommended that the ratio of the load ring diameter to that of the support ring be $D_L/D_S = 0.2$. The sizes of the load and support rings depend on the dimensions and the properties of the ceramic material to be tested. The rings are sized to the thickness, diameter, strength, and elastic modulus of the ceramic test specimens (see Section 8). For test specimens made from typical substrates ($h \approx 0.5$ mm), a support ring diameter as small as 12 mm may be required. For test specimens to be used for model verification, it is recommended that the test specimen support diameter be at least 35 mm. The tip radius, r , of the cross sections of the load and support rings should be $h/2 \leq r \leq 3 h/2$.

6.2.3 *Load and Support Ring Materials*— For machined test specimens (see Section 8) the load and support fixtures shall be made of hardened steel of $HR_C > 40$. For as-fabricated test specimens, the load/support rings shall be made of steel or acetyl polymer.

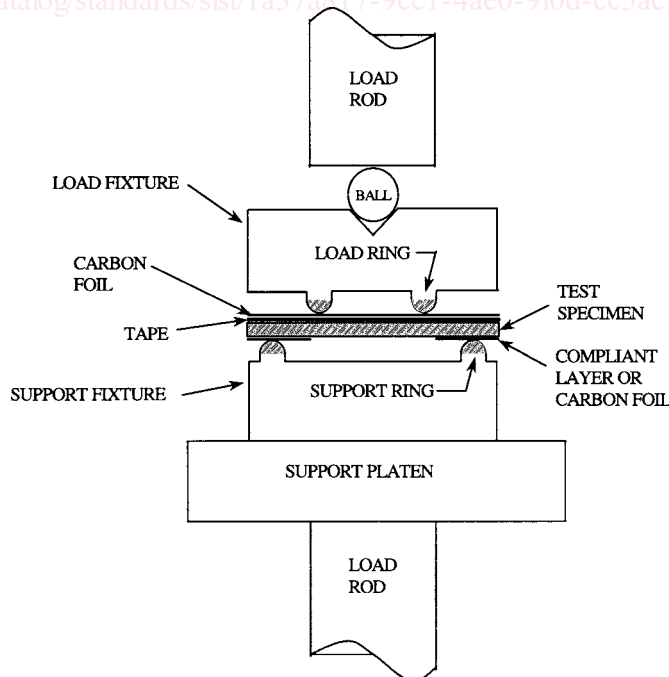
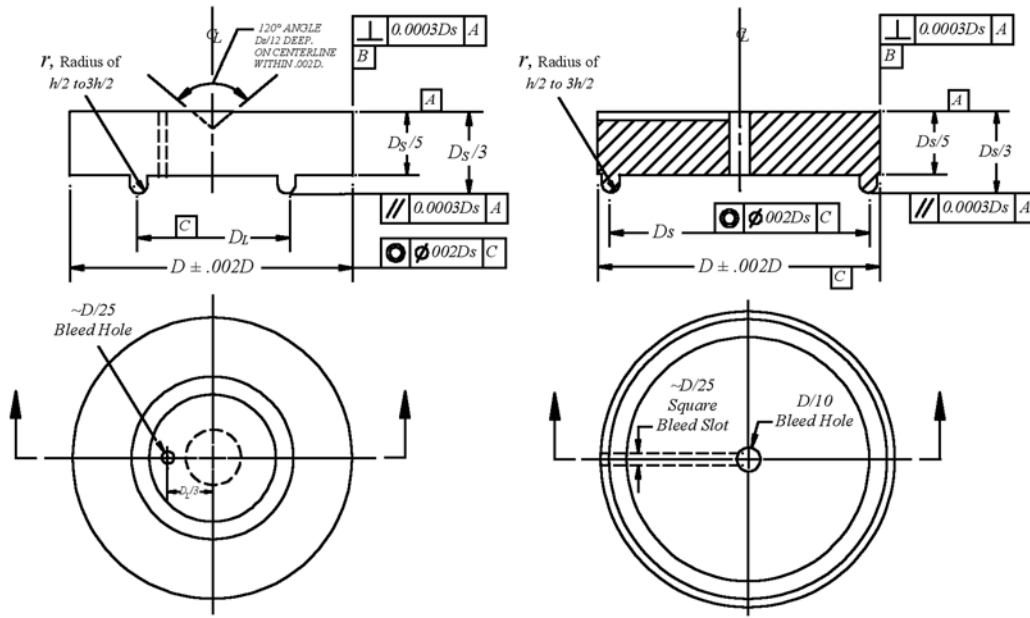

FIG. 1 Section View of Basic Fixturing and Test Specimen for Equibiaxial Testing



NOTE—0.4 to 0.8 μm surface finish. Harden to 40 Rc or greater.
FIG. 2 Load and Support Fixture Designs for Equibiaxial Testing

6.2.4 *Compliant Layer and Friction Elimination*—The brittle nature of advanced ceramics and the sensitivity to misalignment, contact stresses and friction may require a compliant interface between the load/support rings and the test specimen, especially if the test specimen is not flat. Line or point contact stresses and frictional stresses can lead to crack initiation and fracture of the test specimen at stresses other than the actual equibiaxial strength.

6.2.4.1 *Machined Test Specimens*—For test specimens machined according to the tolerance in Fig. 3, a compliant layer is not necessary. However, friction needs to be eliminated. Place a sheet of carbon foil (~0.13 mm thick) or Teflon tape (~0.07 mm thick) between the compressive and tensile surfaces of the test specimen and the load and support rings.

NOTE 1—Thicker layers of carbon foil or Teflon tape may be used, particularly for very strong plates. However, excessively thick layers will redistribute the contact region and may affect results. The thicknesses listed above have been used successfully. Guidance regarding the use of thick layers cannot be given currently; some judgement may be required.

Alternatively, an appropriate lubricant (anti-seizing compound or Teflon oil) may be used to minimize friction. The lubricant should be placed only on the load and support rings so that effects of the test environment are not significantly altered. To aid fractographic examination, place a single strip of adhesive tape with a width of D_L or greater on the compressive face of the test specimen. Do not use multiple strips of tape, or a strip of tape with width less than D_L , as this may result in nonuniform loading.

6.2.4.2 *As-Fabricated Test Specimens*—If steel load and support rings are used to test as-fabricated test specimens (for example, as-fired ceramics and glass test specimens), minimize the effects of test specimen-ring misalignment by placing a sheet of rubber

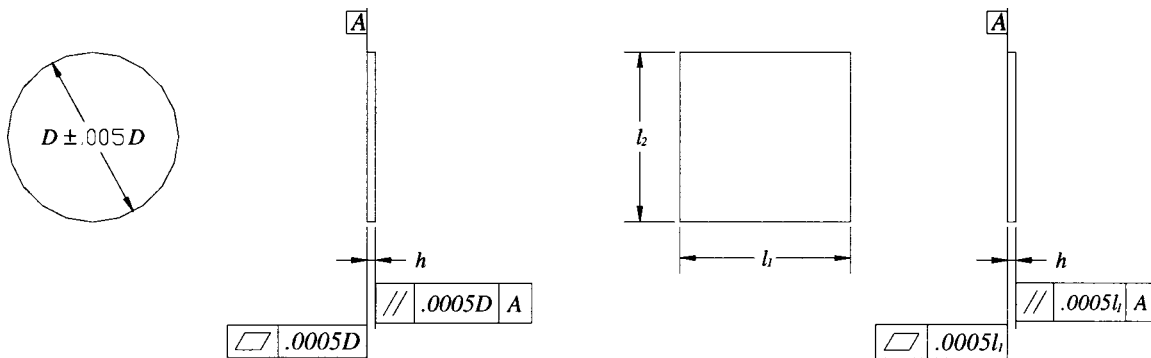

Round Test Specimen

Rectangular Test Specimen

FIG. 3 Recommended Equibiaxial Test Specimen Geometry (h and D or l_1 and l_2 are Determined from Eq 1-3).

or silicone (shore hardness of 60 ± 5) of approximately one-half the test specimen thickness between the test specimen and the support ring. To aid fractographic examination, place a single strip of adhesive tape with a width of D_L or greater on the compressive face of the test specimen. Do not use multiple strips of tape, or a strip of tape with width less than D_L , as this may result in nonuniform loading. To minimize the effects of friction at the load ring interface, place a sheet of carbon foil or TFE-fluorocarbon tape between the compressive surface of the test specimen and the load-ring. Alternatively, an appropriate lubricant (anti-seizing compound or TFE-fluorocarbon oil) may be used to minimize friction at the load ring. If acetyl polymer load rings are used, a compliant layer is not required. Minimize the effects of friction at the load ring interface, by placing a sheet of carbon foil or TFE-fluorocarbon tape between the compressive and tensile surfaces of the test specimen and the load and support rings. Alternatively, an appropriate lubricant (anti-seizing compound or TFE-fluorocarbon oil) may be used to minimize friction at the load ring.

NOTE 2—As-fabricated test specimens that meet the flatness requirements in Fig. 3 may be tested as described in 6.2.4.1. A compliant layer is not necessary.

NOTE 3—The use of acetyl polymer load rings can result in sufficiently low friction (4) so that no layer is required. If the friction coefficient is less than 0.05, then the friction reduction layer may be eliminated.

6.3 *Alignment*—The load ring and support ring shall be aligned concentrically to 0.5 % of the support ring diameter. The test specimen shall be concentric with the load and support rings to 2 % of the support ring diameter.

6.4 *Allowable Deflection*—Excessive deflections can result in a calculated equibiaxial strength different than the actual equibiaxial strength. The test specimens allowed in this standard are designed to avoid excessive deflection (3, 5-7). Measurement of deflection is not required, however, center-point deflection can be measured using a deflectometer mounted in the test fixturing (Practice E 83). Load-point deflection also may be measured via the test machine actuator, however, appropriate corrections for the test system compliance may need to be applied to the deflection data. Alternatively, deflection can be estimated via the elastic solutions given in section 10.1.

6.5 *Data Acquisition*—At the minimum, obtain an autographic record of applied load versus time. Either analog chart recorders or digital data acquisition systems can be used for this purpose although a digital record is recommended for ease of later data analysis. Ideally, an analog chart recorder or plotter should be used in conjunction with the digital data acquisition system to provide an immediate record of the test as a supplement to the digital record. Recording devices shall be accurate to within ± 1 % of the selected range for the testing system including readout unit, as specified in Practice E 4, and shall have a minimum data acquisition rate of 10 Hz with a rate of 50 Hz preferred for the rates recommended in section 9.2.2. If faster loading rates are used, then use an acquisition rate adequate to provide an error less than ± 1 % in the load reading.

6.5.1 Record crosshead displacement of the test machine or time similarly to the load or as independent variables of load.

6.6 *Dimension-Measuring Devices*—Micrometers and other devices used for measuring linear dimensions shall be accurate and precise to at least one half the smallest unit to which the individual dimension is required to be measured. For measuring the thickness, a micrometer with flat anvil faces a resolution better than or equal 0.002 mm is required. Ball-tipped or sharp anvil micrometers are not allowed because localized damage (for example, cracking) can be induced.

NOTE 4—Thickness measurement is especially critical to the calculation of the strength when the test specimens are less than 1 mm thick.

7. Precautionary Statement

7.1 Fractures of loaded advanced ceramics can occur at large loads and high strain energies. To prevent the release of uncontrolled fragments, polycarbonate shielding or equivalent is recommended for operator safety and to capture test specimen fragments to aid fractography.

7.2 Fractures can create fine particles that may be a health hazard. Materials containing whiskers, small fibers or silica particles may also cause health hazards. For such materials, the operator is advised to consult the material safety data sheet for guidance prior to testing. Suitable ventilation or masks may be warranted.

8. Test Specimens

8.1 *Test Specimen Dimensions*—Fig. 3 illustrates test specimen geometry. The relative dimensions are chosen to ensure behavior reasonably described by simple plate theory. Choose the dimension such that the test specimen thickness, h , in units of mm, is

$$\frac{D_S}{10} \geq h \geq \sqrt{2\sigma_f D_S^2 / 3E} \quad (1)$$

where:

D_S = the support ring diameter in units mm,

σ_f = the expected equibiaxial fracture strength in units MPa, and

E = the modulus of elasticity in units MPa (Test Method C 1259).

Choose the test specimen and support ring diameters such that the difference in diameters ($D - D_S$) is

$$2 \leq \frac{D - D_S}{h} \leq 12 \quad (2)$$

where:

D = the test specimen diameter in units of mm for circular test specimens.

NOTE 5—For test specimens machined according to 8.2.3, a non-dimensionalized overhang of $(D-D_s)/h = 2$ is generally sufficient. However, for test specimens that are scored from larger plates or for test specimens with poor edge finish, a nondimensionalized overhang of $(D-D_s)/h = 12$ may be required. For optical materials, nondimensionalized overhang larger than 12 may be required. Eq 7 is valid for overhangs as large as $(D-D_s)/h = 24$. However, such large overhang substantially alters the stress distribution, and tests performed with large overhang may result in substantially different measured strengths than tests performed with much smaller overhang. Thus, overhang of $(D-D_s)/h \leq 24$ is allowed. However, it is recommended that $(D-D_s)/h \leq 12$ be used. The edge stress for $D_s/h = 10$ varies from ~30% to ~50% of the maximum stress as $(D-D_s)/h$ varies from 12 to 2, respectively. For $D_s/h = 30$, the edge stress varies from ~12% to ~40% of the maximum stress as $(D-D_s)/h$ varies from 12 to 2, respectively [18]. The exact solution for the tangential stress at the edge of a circular plate can be calculated from:

$$\sigma_e = \frac{3F(1-\nu)(D_s^2 - D^2)}{2\pi h^2 D^2}$$

where the variables are as defined in Eq 1 and Eq 2.

It is recommended that the test specimens be circular, however, in some cases it is advantageous to fabricate rectangular test specimens. For a rectangular test specimen, the value of D for calculations with Eq 1 and Eq 2 is:

$$D = 0.54(l_1 + l_2) \quad (3)$$

where:

l_1 and l_2 = the lengths of the edges. The edge lengths should be within $0.98 \leq l_1/l_2 \leq 1.02$.

8.2 *Test Specimen Preparation: Machined Test Specimens*—A variety of surface preparations are acceptable. Unless the process used is proprietary, report specifics about the stages of material removal, wheel grits, wheel bonding, amount of material removed per pass, and type of coolant used. Regardless of the procedure used to machine the tensile surface of the test specimen, the flatness of the faces as well as the flatness of the edges shall be as specified in Fig. 3.

8.2.1 *Application-Matched Machining*—The tensile face of the equibiaxial test specimen will have the same surface/edge preparation as that given to a service component.

NOTE 6—An example of application matched machining is blanchard grinding of electronic substrates. Although damage may exist, it is acceptable as the component has such damage in its application.

8.2.2 *Customary Practices*—In instances where a customary machining procedure has been developed that is completely satisfactory for a class of materials (that is, it induces negligible surface/subsurface damage or residual stresses), this procedure may be used to machine the equibiaxial test specimens.

NOTE 7—Uniaxial surface grinding creates surface and subsurface microcracks, which may (or may not) be the strength-controlling flaws. Such machining cracks usually are oriented relative to the grinding direction and consequently may cause a pronounced variation in the uniaxial strength as a function of the test specimen orientation. If machining flaws dominate, equibiaxial test specimens will fail from the worst orientation and the measured equibiaxial strength will be representative of the machining damage. Further, the equibiaxial strength data may not correlate well with uniaxial data generated with standardized procedures that minimize the effects of such populations (8). Lapping or annealing can be used to minimize such effects in both equibiaxial strength tests and advanced ceramic components subjected to multiaxial stresses. Lapping needs to be sufficiently deep to remove machining damage (typically 10 to 30 μm deep). Note that surface finish is not a good indicator of the absence of machining damage.

8.2.3 *Recommended Procedure*—In instances where 8.2.1 or 8.2.2 are not appropriate, 8.2.3.1-8.2.3.4 shall apply.

8.2.3.1 Perform all grinding or cutting with ample supply of appropriate filtered coolant to keep the test specimen and grinding wheel constantly flooded and particles flushed. Grinding can be done in two stages, ranging from coarse to fine rates of material removal. All cutting can be done in one stage appropriate for the depth of cut.

8.2.3.2 The stock removal rate shall not exceed 0.03 mm per pass to the last 0.06 mm of material removed. Final finishing shall use diamond tools between 320 and 500 grit. No less than 0.06 mm shall be removed during the final finishing stage, and at a rate less than 0.002 mm per pass. Remove equal stock from opposite faces.

8.2.3.3 Grinding is followed by either annealing or lapping, as deemed appropriate.

NOTE 8—For alpha silicon carbide, annealing at ~1200°C in air for ~2 hours was sufficient to heal the grinding damage induced by the procedure in 8.2.3.2 without otherwise altering the material's strength (8). However, note that annealing can significantly alter a material's properties (9, 10), and specific procedures will need to be developed for each material.

NOTE 9—For lapping of alpha silicon carbide, the following procedure was successful in elimination of machining damage induced by uniaxial grinding: successive lapping with 15, 9 and 6 μm diamond pastes for ~30, ~25 and ~15 minutes respectively (11). Approximately 10 μm of materials was removed. For tungsten carbide, successive machine lapping with 15 and 6 μm diamond pastes for ~60 and ~30 minutes, respectively, with a pressure of ~13.8 kPa was sufficient (12). Specific procedures will need to be developed for other materials.

8.2.3.4 To aid in post failure fractographic examination, it is recommended that the orientation of the grinding direction be marked on the test specimens. This can be accomplished with an indelible marker.

8.3 *Test Specimen Preparation: As-Fabricated Test Specimens*—In order to simulate the surface condition of an application in which no machining is used, limited testing of as-fabricated surfaces is allowed and precautions are recommended. The test specimen should be flat to 0.1 mm in 25 mm. For test specimens exhibiting less flatness, it is suggested that the user consider Test Method F 394 or the use of fixturing designed to accommodate warped test specimens (for example, (13)). Data generated via this