



Designation: D 5233 – 92 (Reapproved 1999)

## Standard Test Method for Single Batch Extraction Method for Wastes<sup>1</sup>

This standard is issued under the fixed designation D 5233; the number immediately following the designation indicates the year of original adoption or, in the case of revision, the year of last revision. A number in parentheses indicates the year of last reapproval. A superscript epsilon ( $\epsilon$ ) indicates an editorial change since the last revision or reapproval.

### 1. Scope

1.1 This test method is applicable to the extraction of samples of treated or untreated solid wastes or sludges, or solidified waste samples, to provide an indication of the leaching potential.

1.2 This test method is intended to provide an extract for measurement of the concentration of the analytes of concern. The measured values may be compared against set or chosen acceptance levels in some applications.

1.3 If the sole application of the test method is such a pass/fail comparison and a total analysis of the waste demonstrates that individual analytes are not present in the waste, or that the chosen acceptance concentration levels could not possibly be exceeded, the test method need not be run.

1.4 If the sole application of the test method is such a pass/fail comparison and an analysis of any one of the liquid fractions of the extract indicates that the concentration of the target analyte is so high that, even after accounting for dilution from the other fractions of the extract, it would be equal to or above an acceptance concentration level, then the waste fails the test. In such a case it may not be necessary to analyze the remaining fractions of the extract.

1.5 This test method is intended to provide an extract suitable for the measurement of the concentration of analytes that will not volatilize under the conditions of the test method.

1.6 Presence of volatile analytes may be established if an analysis of the extract obtained using this test method detects the target volatile analyte. If its concentration is equal to or exceeds an acceptance level for that analyte, the waste fails the test. However, extract from this test method shall not be used to determine the concentration of volatile organic analytes.

1.7 This test method is intended to describe only the procedure for performing a batch extraction. It does not describe all of the sampling and analytical requirements that may be associated with the application of this test method.

1.8 The values stated in either SI or inch-pound units are to be regarded as the standard. The values given in parentheses are for information only.

1.9 *This standard does not purport to address all of the safety problems, if any, associated with its use. It is the responsibility of the user of this standard to establish appropriate safety and health practices and determine the applicability of regulatory limitations prior to use.* For a specific precautionary statement, see Note 8.

### 2. Referenced Documents

#### 2.1 ASTM Standards:

D 75 Practices for Sampling Aggregates<sup>2</sup>

D 420 Practice for Investigating and Sampling Soil and Rock for Engineering Purposes<sup>3</sup>

D 653 Terminology Relating to Soil, Rock, and Contained Fluids<sup>3</sup>

D 1129 Terminology Relating to Water<sup>4</sup>

D 1193 Specification for Reagent Water<sup>4</sup>

D 2234 Test Method for Collection of a Gross Sample of Coal<sup>5</sup>

D 3370 Practices for Sampling Water<sup>4</sup>

E 122 Practice for Choice of Sample Size to Estimate A Measure of Quality for a Lot or Process<sup>6</sup>

ES 16 Practice for the Generation of Environmental Data Related to Waste Management Activities<sup>7</sup>

### 3. Terminology

3.1 Definitions—For definitions of terms used but not defined in this test method, see Terminology D 1129.

### 4. Summary of Test Method (See Fig. 1)

4.1 For wastes containing less than 0.5 % dry solid material, the filtrate of the waste, after filtration through a 0.6 to 0.8- $\mu$ m glass fiber filter, is defined as the method extract. Extraction of the solid is not required for such wastes.<sup>8,9</sup>

<sup>1</sup> This test method is under the jurisdiction of ASTM Committee D34 on Waste Disposal and is the direct responsibility of Subcommittee D34.01.06 on Analytical Methods.

Current edition approved March 15, 1992. Published May 1992.

<sup>2</sup> *Annual Book of ASTM Standards*, Vol 04.03.

<sup>3</sup> *Annual Book of ASTM Standards*, Vol 04.08.

<sup>4</sup> *Annual Book of ASTM Standards*, Vol 11.01.

<sup>5</sup> *Annual Book of ASTM Standards*, Vol 05.05.

<sup>6</sup> *Annual Book of ASTM Standards*, Vol 14.02.

<sup>7</sup> *Annual Book of ASTM Standards*, Vol 11.04 (see 1991 edition).

<sup>8</sup> *Federal Register*, Vol 55, No. 61, March 29, 1990. Toxicity Characteristics Revisions, Final Rule.

<sup>9</sup> *Federal Register*, Vol 55, No. 126, June 29, 1990. Toxicity Characteristic Revisions, Final Rule, Corrections.

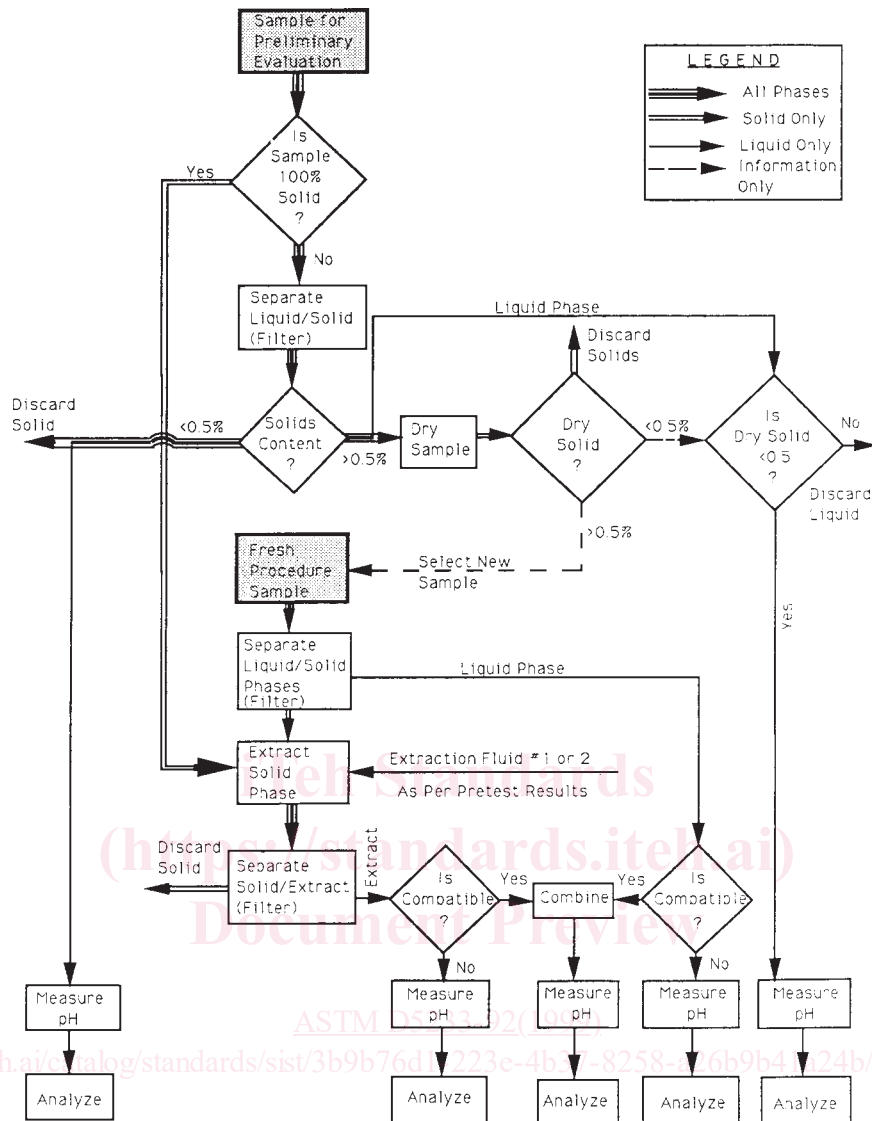

FIG. 1 Method Flow Chart

4.2 For wastes containing greater than or equal to 0.5 % dry solid material, the liquid, if any, is separated from the solid phase and stored for later analysis. The solid phase is extracted with an amount of extraction fluid equal to 20 times the weight of the solid phase. The extraction fluid used is a function of the alkalinity of the solid phase of the waste. Following extraction, the liquid extract is separated from the solid phase by filtration through a 0.6 to 0.8- $\mu$ m glass fiber filter.

4.3 If compatible (that is, multiple phases will not form upon combination), the initial liquid phase of the waste is added to the liquid extract, and these are analyzed together. If incompatible, the liquids are analyzed separately and the results are combined mathematically to yield a volume-weighted average concentration.

**5. Significance and Use**

5.1 This test method is intended to generate an extract with a concentration of the target analyte(s) representative of the expected release under the scenario simulated, and which can

be compared with concentration levels acceptable in waste disposal, treatment, or production activities.

5.2 The extraction conditions of the test method were chosen to simulate a potential disposal scenario to which the wastes may be exposed.

5.3 One intent of this test method is that the amount of acid in the extraction fluids reflect the acid available from the leachate of a specific landfill where municipal and industrial wastes were co-disposed.<sup>10</sup>

5.4 One intent of this test method is to not allow the pH of the extraction fluid to be lower than that of the leachate of a specific landfill where municipal and industrial wastes were co-disposed. Therefore, the pH of the extraction fluid was chosen with the following considerations:

<sup>10</sup> Kimmel, T. A., and Friedman, D. A., "Model Assumptions and Rationale Behind the Development of EP III," *ASTM STP 886*, J. K. Petros, et al, Eds., ASTM, Philadelphia, PA, 1986, pp. 36-53.

(1) Not to be less than  $4.93 \pm 0.05$  for the extraction of wastes with an acid neutralization capacity of less than the acid available in the total volume of extraction fluid used in the method (Extraction Fluid No. 1).

(2) At  $2.88 \pm 0.05$ , as defined by the pH of the acid, for the extraction of wastes with an acid neutralization capacity of more than the acid available in the extraction fluid used in the method (Extraction Fluid No. 2).

5.5 The interpretation and use of the results of this test method are limited by the assumptions of a single co-disposal scenario and by the factors affecting the composition of a landfill leachate and chemical or other differences between a selected extraction fluid and the real landfill leachate.

5.6 This test method may be affected by biological changes in the waste, and it is not designed to isolate or measure the effect of such processes.

5.7 This test method produces extracts that are amenable to the determination of both minor and major constituents. When minor constituents are being determined, it is especially important that precautions be taken in sample storage and handling to avoid possible contamination of the samples.

5.8 The agitation technique, rate, liquid-to-solid ratio, and filtration conditions specified in the method may not be suitable for extracting all types of wastes.

5.9 This test method is intended to extract the samples in their original physical state as is, without any size reduction. However, the sample/extractor interaction is expected to correlate with the environmental conditions to which a waste may be exposed.<sup>11</sup>

5.10 The extraction conditions defined by this test method are expected to yield steady-state concentrations, determined by the extraction liquid-to-solid ratio and the duration of the extraction, which may or may not agree with the concentration of an equilibrium.

## 6. Apparatus and Materials

6.1 *Agitation Apparatus*, capable of rotating the extraction vessel in an end-over-end fashion (see Fig. 2), at  $30 \pm 2$  r/min, such that the axis of rotation is horizontal and passes through the center of the bottle.

NOTE 1—Similar devices may be used having a different axle arrangement if equivalency can be demonstrated.

<sup>11</sup> Federal Register, Vol 53, No. 100, May 24, 1988. Proposed Cage Modification of TCLP.

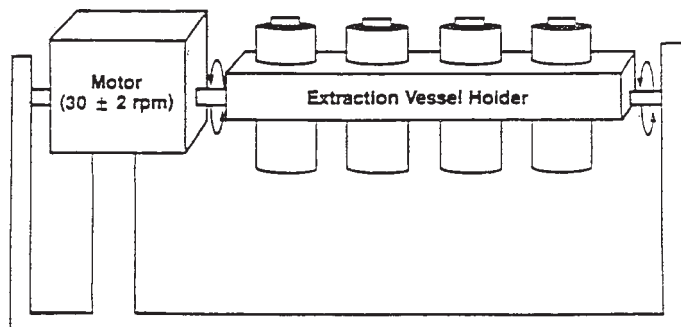

FIG. 2 Rotary Agitation Apparatus

6.2 *Extraction Vessel*—Suitable vessels include cylindrically shaped, minimum 2-L size, with capacity sufficient to hold the sample and the extraction fluid. Head-space is allowed in this vessel. The extraction bottles may be constructed from various plastic materials, depending on the analytes of interest and the nature of the waste. Plastic bottles, other than polytetrafluoroethylene, shall not be used if organics are to be investigated. The bottles should be sturdy, in order to withstand the impact of the falling sample fragments, and shall have a leak-free seal. The use of polytetrafluoroethylene tape is recommended to ensure a tight seal. Due to their potential for breakage, the use of glass bottles is not recommended.

NOTE 2—Suitable bottles range from 4.0 to 4.5 in. (102 to 114 mm) in diameter and from 8.5 to 13.0 in. (216 to 330 mm) in height.

6.3 *Filtration Device*—It is recommended that all filtrations be performed in a hood. Wastes should be filtered using positive-pressure filtration using a pre-purified grade inert gas such as nitrogen.

6.3.1 *Filter Holder*, capable of supporting a glass fiber filter and able to withstand the pressure needed to accomplish separation (maximum 50 psi or 345 kPa). These devices shall have a minimum internal volume of 300 mL and shall be equipped to accommodate a minimum filter size of 47 mm. (Filter holders having an internal capacity of 2.2 L and equipped to accommodate a 142-mm diameter filter are recommended.)

6.3.1.1 *Materials of Construction*—Filtration devices shall be made of inert materials that will not leach or adsorb the analytes of concern. Glass, polytetrafluoroethylene, or type 316 stainless steel equipment may be used when both organic and inorganic analytes are of concern. Devices made of high-density polyethylene (HDPE), polypropylene (PP), or polyvinylchloride (PVC) may be used when only inorganics are of concern.

6.4 *Filters*, made of borosilicate glass fiber, containing no binder materials, and having an effective pore size of 0.6 to  $0.8\mu$  m. Pre-filters must not be used. When inorganic analytes are of concern, the filter shall be acid washed prior to use by rinsing with 1 N nitric acid followed by three consecutive rinses with Type II reagent water as defined in Specification D 1193. (A minimum of 1 L per rinse is recommended.) Glass fiber filters are fragile and should be handled with care.

6.5 *pH Meter*, with a readability of 0.01 unit and an accuracy of  $\pm 0.05$  unit at 25°C.

6.6 *Laboratory Balance*, accurate to within  $\pm 0.01$  g. (All weight measurements are to be within  $\pm 0.1$  g.)

6.7 *Beakers or Erlenmeyer Flasks*, glass 500-mL, and 2-L.

6.8 *Watch-Glass*, with an appropriate diameter to cover the beaker or Erlenmeyer flask.

6.9 *Magnetic Stirrer*.

6.10 *Mold*, cylindrical, made of inert, non-adsorbing and non-contaminating material for casting of laboratory samples.

6.11 *Straightedge*, made of stainless steel.

6.12 *Impermeable Sheet or Glazed Paper*.

6.13 *Volumetric Flask*, 1-L size.

6.14 *Drying Oven*—Any thermostatically controlled drying oven capable of maintaining a temperature between 85 and 115°C within  $\pm 5$ °C.

6.15 *Graduated Pipet*, readable to 0.1 mL.

6.16 *Hot Plate*, equipped for agitation and temperature control capable of maintaining a  $50 \pm 3^\circ\text{C}$  temperature.

6.17 *Graduated Measuring Cylinder*, with a precision of  $\pm 3\%$ .

## 7. Reagents

7.1 *Purity of Reagents*—Reagent grade chemicals shall be used in all tests. Unless otherwise indicated, it is intended that all reagents shall conform to the specifications of the Committee on Analytical Reagents of the American Chemical Society, where such specifications are available.<sup>12</sup> Other grades may be used, provided it is first ascertained that the reagent is of sufficiently high purity to permit its use without lessening the accuracy of the determination.

7.2 *Purity of Water*—Reagent water is defined as water in which an interfering analyte is not observed at or above the method detection limit of the analyte(s) of interest. Type II of Specification D 1193 or equivalent meets the definition of reagent water.

7.3 *Hydrochloric Acid* (HCl), 1 N, made from ACS reagent grade.

7.4 *Nitric Acid* (HNO<sub>3</sub>), 1 N, made from ACS reagent grade.

7.5 *Sodium Hydroxide* (NaOH), 1 N, made from ACS reagent grade.

7.6 *Glacial Acetic Acid* (CH<sub>3</sub>COOH), ACS reagent grade.

7.7 *Extraction Fluids*—Several batches or multiple volumes of extraction fluids should be prepared in accordance with the number of extractions. The volume needed for an individual extraction is approximately 2 L. The extraction fluids should be monitored frequently for impurities. The pH should be examined prior to extraction to ensure that these fluids were made up accurately. If impurities are found or the pH is not within the specifications, the fluid shall be discarded and fresh extraction fluid prepared.

7.7.1 *Extraction Fluid No. 1*—Add 5.7 mL glacial acetic acid to 500 mL of reagent water, add 64.3 mL of 1 N NaOH, and dilute to a volume of 1 L. When correctly prepared, the pH of this fluid will be  $4.93 \pm 0.05$ .

7.7.2 *Extraction Fluid No. 2*—Dilute 5.7 mL glacial acetic acid with reagent water to a volume of 1 L. When correctly prepared, the pH of this fluid will be  $2.88 \pm 0.05$ .

## 8. Sampling

8.1 If representative samples of the waste must be tested, use ASTM Sampling methods developed for the specific industry where available (see Practices D 75, D 420, D 3370, Terminology D 653, and Method D 2234).

8.2 All samples shall be collected using an appropriate sampling plan to ensure sample integrity and representativeness (see Practice E 122).

8.3 Where no specific methods are available, sampling methodology for materials of similar physical form shall be used.

8.4 It is important that the sample of the waste be representative with respect to surface area, as variations in surface area would directly affect the extraction characteristics of the sample. Waste samples should contain a representative distribution of particle sizes.

NOTE 3—Information on obtaining representative samples can also be found in *Pierre Gy's Sampling Theory and Practice*.<sup>13</sup>

8.5 Approximately 100 g of solid phase samples are required for each extraction. Preliminary evaluation also requires 100 g of solid phase sample. A larger sample size may be required, depending on the solids content of the waste sample (percent solids; see 10.2.9).

8.6 Enough extract should be generated such that the volume will be sufficient to support all of the analyses required. If the volume of extract generated by the performance of a single extraction will not be sufficient to perform all of the analyses to be conducted, it is recommended that more than one extraction be performed and that the extracts from each extraction be combined and then aliquoted for analysis.

8.7 For the evaluation of solidified or stabilized wastes, or both, samples may be cast in the form of a cylinder that will fit into the extraction apparatus. Such cylinders may be used for the evaluation. The casting may be allowed to cure for 30 days before the extraction procedure is performed. For other monolithic materials, a coring may be produced that will fit into the extraction apparatus. Waste materials to which these casting and coring procedures apply include concrete materials, rock, wood, slag, and so forth.

8.8 Quality control measures may require additional samples.

## 9. Sample Handling and Preparation

9.1 For free-flowing particulate solid wastes, obtain a sample in accordance with the requirements of Section 8 by quartering the sample received for testing on an impermeable sheet of glazed paper, or other flexible non-contaminating material, as follows:

9.1.1 Empty the sample container into the center of the sheet.

9.1.2 Flatten out the sample gently with a suitable straight-edge until it is spread uniformly to a depth at least twice the maximum particle diameter.

9.1.3 Remix the sample by lifting a corner of the sheet and drawing low across to the opposite corner in the manner that the material is made to roll over and over and does not merely slide along. Return that corner to its original position. Continue the operation with each corner, proceeding in a clockwise direction. Repeat this cycle ten times.

9.1.4 Lift all four corners of the sheet toward the center, and holding all four corners together, raise the entire sheet into the air to form a pocket for the sample.

<sup>12</sup> "Reagent Chemicals, American Chemical Society Specifications," Am. Chemical Soc., Washington, DC. For suggestions on the testing of reagents not listed by the American Chemical Society, see "Reagent Chemicals and Standards," by Joseph Rosin, D. Van Nostrand Co., Inc., New York, NY, and the "United States Pharmacopeia."

<sup>13</sup> Pitard, F., *Pierre Gy's Sampling Theory and Practice*, Volumes I and II, CRC Press, 1989.