



SLOVENSKI STANDARD
SIST ISO 1722:1997
01-avgust-1997

JfHUb^_Ua b]b!`CdfYa UnUdcXU^Yj Ub^Yj fHUbY[UXfc[cj ^Udf]i XUfbYa `j fHUb^
Xc`[] `j fHUb!`CdfYa Ug'dcj fUbc`c^U Yb]a]^bUj c^1%#&`Xc`&%&`fl , `Xc*(`a a Ł

Rock drilling -- Extension drill-steel equipment for percussive long-hole drilling -- Reverse
-buttress-threaded equipments 1 1/2 to 2 1/2 in (38 to 64 mm)

iTeh STANDARD PREVIEW

Forage des roches -- Matériels (pour forage percutant de longs trous -- Équipements à
filetage à butée inverse 1 1/2 à 2 1/2 in (38 à 64 mm)

[SIST ISO 1722:1997](https://standards.iteh.ai/catalog/standards/sist/2175dcae-0ff6-4695-a27f-24ac31779081/sist-iso-1722-1997)

Ta slovenski standard je istoveten z: **ISO 1722:1974**

ICS:

73.100.30	Oprema za vrtanje in izkopavanje	Equipment for drilling and mine excavation
-----------	----------------------------------	--

SIST ISO 1722:1997 en

iTeh STANDARD PREVIEW
(standards.iteh.ai)

SIST ISO 1722:1997

<https://standards.iteh.ai/catalog/standards/sist/2175dcae-0ff6-4695-a27f-24ac3f779081/sist-iso-1722-1997>

INTERNATIONAL STANDARD**1722**

INTERNATIONAL ORGANIZATION FOR STANDARDIZATION • МЕЖДУНАРОДНАЯ ОРГАНИЗАЦИЯ ПО СТАНДАРТИЗАЦИИ • ORGANISATION INTERNATIONALE DE NORMALISATION

Rock drilling — Extension drill-steel equipment for percussive long-hole drilling — Reverse-buttress-threaded equipments 1 1/2 to 2 1/2 in (38 to 64 mm)

Forage des roches — Matériels pour forage percutant de longs trous — Équipements à filetage à butée inverse 1 1/2 à 2 1/2 in (38 à 64 mm)

iTeh STANDARD PREVIEW

First edition — 1974-09-15

(standards.iteh.ai)

[SIST ISO 1722:1997](https://standards.iteh.ai/catalog/standards/sist/2175dcae-0ff6-4695-a27f-24ac3f779081/sist-iso-1722-1997)

<https://standards.iteh.ai/catalog/standards/sist/2175dcae-0ff6-4695-a27f-24ac3f779081/sist-iso-1722-1997>

FOREWORD

ISO (the International Organization for Standardization) is a worldwide federation of national standards institutes (ISO Member Bodies). The work of developing International Standards is carried out through ISO Technical Committees. Every Member Body interested in a subject for which a Technical Committee has been set up has the right to be represented on that Committee. International organizations, governmental and non-governmental, in liaison with ISO, also take part in the work.

Draft International Standards adopted by the Technical Committees are circulated to the Member Bodies for approval before their acceptance as International Standards by the ISO Council.

Prior to 1972, the results of the work of the Technical Committees were published as ISO Recommendations; these documents are now in the process of being transformed into International Standards. As part of this process, Technical Committee ISO/TC 82 has reviewed ISO Recommendation R 1722 and found it suitable for transformation. International Standard ISO 1722 therefore replaces ISO Recommendation R 1722-1970.

[SIST ISO 1722:1997](https://standards.iteh.ai/catalog/standards/sist/2175dcae-0ff6-4695-a27f-24c31779061/sist-iso-1722-1997)

ISO Recommendation R 1722 was approved by the Member Bodies of the following countries :

Australia	Hungary	Poland
Belgium	India	South Africa, Rep. of
Canada	Iran	Spain
Czechoslovakia	Israel	Sweden
Egypt, Arab Rep. of	Italy	Thailand
France	Japan	Turkey
Germany	Netherlands	United Kingdom
Greece	New Zealand	Yugoslavia

No Member Body expressed disapproval of the Recommendation.

The Member Body of the following country disapproved the transformation of ISO/R 1722 into an International Standard :

Canada

Rock drilling – Extension drill-steel equipment for percussive long-hole drilling – Reverse-buttress-threaded equipments 1 1/2 to 2 1/2 in (38 to 64 mm)

iTeh STANDARD PREVIEW
(standards.iteh.ai)

1 SCOPE AND FIELD OF APPLICATION

This International Standard specifies the basic dimensions for reverse-buttress-threaded extension drill-steel equipment for percussive long-hole drilling of the following nominal sizes :

- 1 1/2 in light (38 mm)
- 1 3/4 in light (45 mm)
- 2 1/4 in light (52 mm)
- 2 1/2 in light (64 mm)

2 REFERENCE

ISO 723, *Rock drilling – Forged collared shanks and chuck bushings for hollow hexagonal drill-steels.*

3 LIST OF COMPONENTS

Equipment	1 1/2 in light (38 mm)		1 3/4 in light (45 mm)		2 1/4 in light (57 mm)		2 1/2 in light (64 mm)	
	mm	ft	mm	ft	mm	ft	mm	ft
Thread diameter	1 1/2 in		1 3/4 in		2 1/4 in		2 1/2 in	
Size of drill-steel in bar form	1 1/4 in hexagonal (32 mm)		1 1/2 in hexagonal (38 mm)		1 3/4 in hexagonal (45 mm)		1 7/8 in hexagonal (48 mm)	
Lengths of extension rods (clause 4)	3 050	10	3 050	10	3 050	10	3 050	10
	3 660	12	3 660	12	3 660	12	3 660	12
	–	–	–	–	6 095	20	6 095	20
Coupling sleeves	See clause 5							
Bit diameters (four-wing bits) (clause 6)	mm	in	mm	in	mm	in	mm	in
	64	2 1/2	–	–	–	–	–	–
	70	2 3/4	–	–	–	–	–	–
	76	3	76	3	–	–	–	–
	89	3 1/2	89	3 1/2	89	3 1/2	–	–
	–	–	102	4	102	4	102	4
	–	–	–	–	115	4 1/2	115	4 1/2
–	–	–	–	–	–	127	5	
Reverse-buttress threads	See clause 7							
Hollow hexagonal bars for extension rods	See clause 8							

ISO 1722-1974 (E)

4 EXTENSION RODS

Section A-A

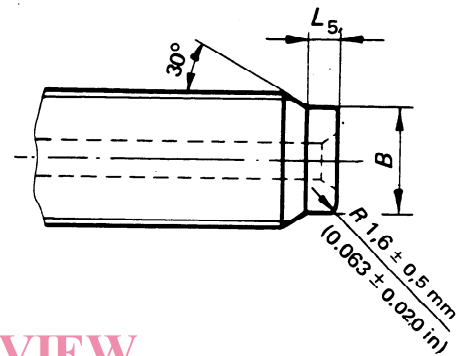
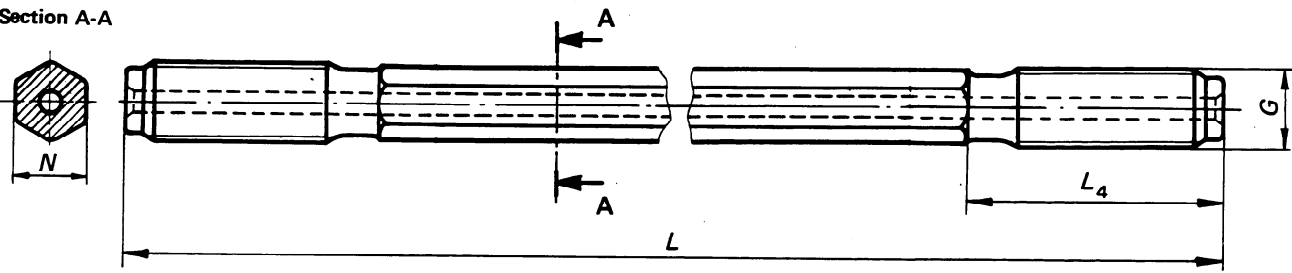

iTeh STANDARD PREVIEW
(standards.iteh.ai)

Dimensions in millimetres

Equipment	Hexagonal drill-rod (see clause 8) N nominal	Thread diameter G nominal	SIST ISO 1722:1997				L ₄ ± 1	L ₅	
			B		L			Basic size	Tolerance
			Basic size	Tolerance	Basic size	Tolerance			
1 1/2 in light	32	1 1/2 in	31,50	0 -0,25	3 050 3 660	± 25	123,8	6,35	± 0,5
1 3/4 in light	38	1 3/4 in	37,85	0 -0,25	3 050 3 660	± 25	133,4	6,35	± 0,5
2 1/4 in light	45	2 1/4 in	51,10	0 -0,30	3 050 3 660 6 095	± 25	122,2*	6,35	± 0,5
2 1/2 in light	48	2 1/2 in	53,90	0 -0,30	3 050 3 660 6 095	± 25	146,0*	7,14	± 0,5

Dimensions in inches

Equipment	Hexagonal drill-rod (see clause 8) N nominal	Thread diameter G nominal	B		L		L ₄ ± 0.039	L ₅	
			Basic size	Tolerance	Basic size fb	Tolerance in		Basic size	Tolerance
1 1/2 in light	1 1/4	1 1/2 in	1.240	0 -0.010	10 12	± 1	4.875	0.250	± 0.020
1 3/4 in light	1 1/2	1 3/4 in	1.490	0 -0.010	10 12	± 1	5.250	0.250	± 0.020
2 1/4 in light	1 3/4	2 1/4 in	2.012	0 -0.012	10 12 20	± 1	4.813*	0.250	± 0.020
2 1/2 in light	1 7/8	2 1/2 in	2.122	0 -0.012	10 12 20	± 1	5.750*	0.281	± 0.020

* No thread undercut is required in this instance.

5 COUPLING SLEEVES

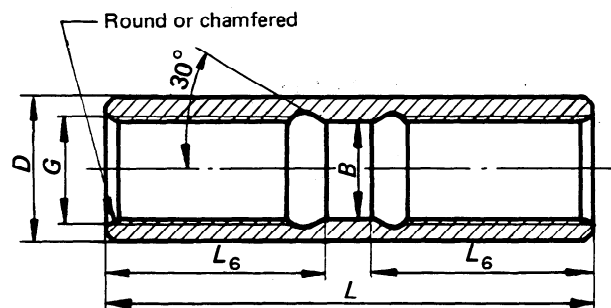

Dimensions in millimetres

Equipment	D max.	Thread diameter G nominal	B		L ₆ L ₆ - 1	L ₆	
			Basic size	Tolerance		Basic size	Tolerance
1 1/2 in light	54,4	1 1/2 in	31,75	+0,5 0	203	96,3	+1 0
1 3/4 in light	64,0	1 3/4 in	38,10	+0,5 0	222	105,0	+1 0
2 1/4 in light	80,0	2 1/4 in	51,36	+0,5 0	254	120,9	+1 0
2 1/2 in light	85,3	2 1/2 in	54,10	+0,5 0	305	147,1	+1 0

Dimensions in inches

Equipment	D max.	Thread diameter G nominal	B		L ₆ L ₆ - 0.039	L ₆	
			Basic size	Tolerance		Basic size	Tolerance
1 1/2 in light	2,14	1 1/2 in	1,250	+0,020 0	8	3,790	+0,039 0
1 3/4 in light	2,52	1 3/4 in	1,500	+0,020 0	8,75	4,134	+0,039 0
2 1/4 in light	3,14	2 1/4 in	2,022	+0,020 0	10	4,759	+0,039 0
2 1/2 in light	3,36	2 1/2 in	2,130	+0,020 0	12	5,790	+0,039 0

ISO 1722-1974 (E)

6 FOUR-WING BITS – X-DESIGN

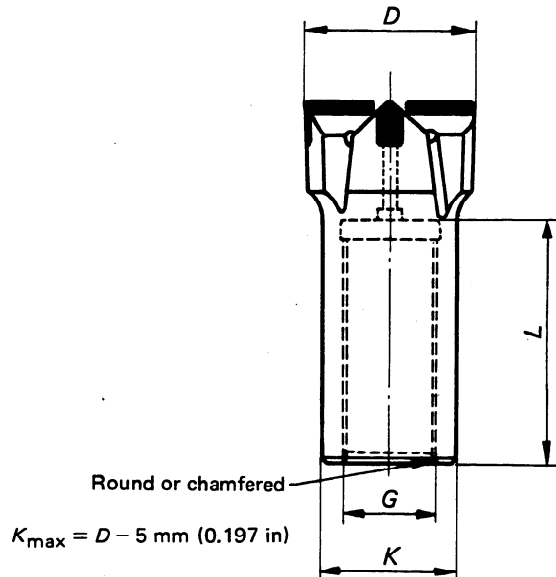

iTeh STANDARD PREVIEW

X-design
(standards.iteh.ai)

<https://standards.iteh.ai/catalog/standards/sist/2175dcae-0ff6-4695-a27f-24ac3f779181/sist-iso-1722-1997>

Equipment	Nominal diameter		D				Thread diameter G nominal	L max.	
			Basic size		Tolerance				
	mm	in	mm	in	mm	in	in	mm	in
1 1/2 in light	64	2 1/2	63,50	2.500	+ 0,6	+ 0.024	1 1/2	82,5	3.25
	70	2 3/4	69,85	2.750					
	76	3	76,20	3.000					
	89	3 1/2	88,90	3.500					
1 3/4 in light	76	3	76,20	3.000	+ 0,6	+ 0.024	1 3/4	82,5	3.25
	89	3 1/2	88,90	3.500	+ 0,6	+ 0.024		82,5	3.25
	102	4	101,60	4.000	+ 1,0	+ 0.039		108,0	4.25
2 1/4 in light	89	3 1/2	88,90	3.500	+ 0,6	+ 0.024	2 1/4	108,0	4.25
	102	4	101,60	4.000	+ 1,0	+ 0.039			
	115	4 1/2	114,30	4.500	+ 1,0	+ 0.039			
2 1/2 in light	102	4	101,60	4.000	+ 1,0	+ 0.039	2 1/2	108,0	4.25
	115	4 1/2	114,30	4.500					
	127	5	127,00	5.000					

7 LEFT-HAND REVERSE-BUTTRESS THREADS

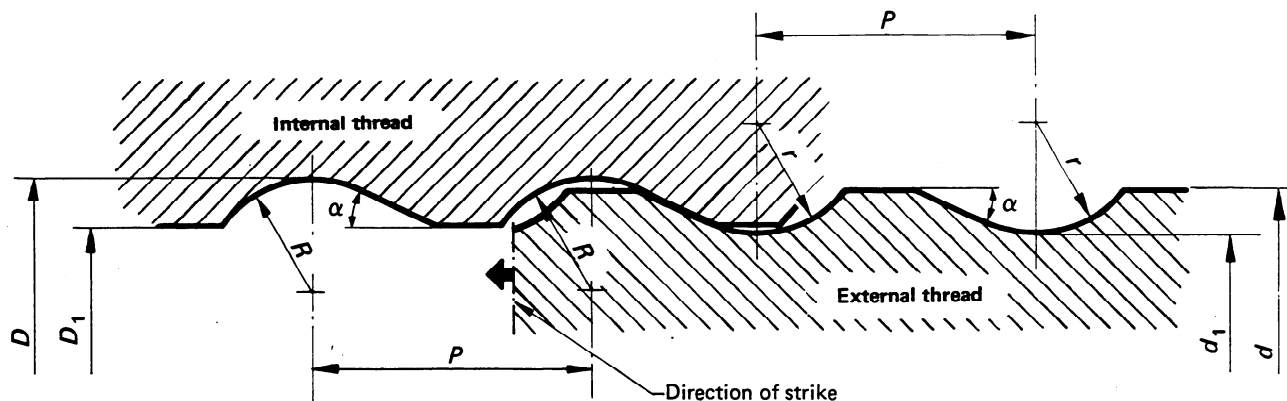

iTeh STANDARD PREVIEW

Dimensions in millimetres

Nominal thread diameter	Internal threads				External threads				Pitch P
	D + 0,10 0	D_1 + 0,13 0	α $\pm 1/2^\circ$	R + 0,4 0	d 0 - 0,08	d_1 0 - 0,08	α $\pm 1/2^\circ$	r + 0,4 0	
1 1/2 in	38,79	33,50	25°	4,39	37,74	33,15	25°	3,58	12,70
1 3/4 in	44,93	39,65	25°	4,39	43,89	39,29	25°	3,58	12,70
2 1/4 in	58,60	53,47	25°	5,16	57,02	52,37	25°	4,76	14,51
2 1/2 in	64,75	56,62	25°	4,37	63,22	55,65	25°	3,78	16,92

Dimensions in inches

Nominal thread diameter	Internal threads				External threads				Pitch P
	D + 0,004 0	D_1 + 0,005 0	α $\pm 1/2^\circ$	R + 0,016 0	d 0 - 0,003	d_1 0 - 0,003	α $\pm 1/2^\circ$	r + 0,016 0	
1 1/2 in	1.527	1.319	25°	0.173	1.486	1.305	25°	0.141	0.500
1 3/4 in	1.769	1.561	25°	0.173	1.728	1.547	25°	0.141	0.500
2 1/4 in	2.307	2.105	25°	0.203	2.245	2.062	25°	0.1875	0.5714
2 1/2 in	2.549	2.229	25°	0.172	2.489	2.191	25°	0.149	0.666