**Road vehicles — Electrical connections
between towing and towed vehicles with
12 V systems — 7 pole connector type 12 N
(normal)**

*Véhicules routiers — Connexions électriques entre véhicule tracteur
et véhicule tracté équipés d'un circuit électrique de 12 V — Connecteur
à 7 contacts de type 12 N (normal)*

(standards.iteh.ai)

[ISO 1724:1997](https://standards.iteh.ai/catalog/standards/sist/25fd2a4a-701e-4a32-8f82-a9cf5e335435/iso-1724-1997)

[https://standards.iteh.ai/catalog/standards/sist/25fd2a4a-701e-4a32-8f82-
a9cf5e335435/iso-1724-1997](https://standards.iteh.ai/catalog/standards/sist/25fd2a4a-701e-4a32-8f82-a9cf5e335435/iso-1724-1997)



Foreword

ISO (the International Organization for Standardization) is a worldwide federation of national standards bodies (ISO member bodies). The work of preparing International Standards is normally carried out through ISO technical committees. Each member body interested in a subject for which a technical committee has been established has the right to be represented on that committee. International organizations, governmental and non-governmental, in liaison with ISO, also take part in the work. ISO collaborates closely with the International Electrotechnical Commission (IEC) on all matters of electrotechnical standardization.

Draft International Standards adopted by the technical committees are circulated to the member bodies for voting. Publication as an International Standard requires approval by at least 75 % of the member bodies casting a vote.

International Standard ISO 1724 was prepared by Technical Committee ISO/TC 22, *Road vehicles*, Subcommittee SC 3, *Electrical and electronic equipment*.

This third edition cancels and replaces the second edition (ISO 1724:1980), which has been technically revised and augmented by the inclusion of specific tests.

ITEH STANDARD PREVIEW
(standards.iteh.ai)

[ISO 1724:1997](#)

<https://standards.iteh.ai/catalog/standards/sist/25fd2a4a-701e-4a32-8f82-a9cf5e335435/iso-1724-1997>

© ISO 1997

All rights reserved. Unless otherwise specified, no part of this publication may be reproduced or utilized in any form or by any means, electronic or mechanical, including photocopying and microfilm, without permission in writing from the publisher.

International Organization for Standardization
Case postale 56 • CH-1211 Genève 20 • Switzerland
Internet central@iso.ch
X.400 c=ch; a=400net; p=iso; o=isocs; s=central

Printed in Switzerland

Road vehicles — Electrical connections between towing and towed vehicles with 12 V systems — 7 pole connector type 12 N (normal)

1 Scope

This International Standard specifies dimensional characteristics and specific requirements for the 7 pole connector type 12 N and its contact allocation for the electrical connection between passenger cars or light commercial vehicles and their towed vehicles equipped with 12 V systems, to ensure their interchangeability.

2 Normative references

The following standards contain provisions which, through reference in this text, constitute provisions of this International Standard. At the time of publication, the editions indicated were valid. All Standards are subject to revision, and parties to agreements based on this International Standard are encouraged to investigate the possibility of applying the most recent editions of the standards indicated below. Members of IEC and ISO maintain registers of currently valid International Standards.

ISO 1103:1996, *Road vehicles — Coupling balls for caravans and light trailers — Dimensions*.

ISO 3732:1997, *Road vehicles — Electrical connections between towing and towed vehicles with 12 V systems — 7 pole connector type 12 S (supplementary)*.

ISO 4091:1992 and Amendment 1:1997, *Road vehicles — Connectors for electrical connections between towing vehicles and trailers — Test methods and performance requirements*.

ISO 4141-1:—¹⁾, *Road vehicles — Multi-core connecting cables — Part 1: Test methods and requirements of basic performance sheathed cables*.

ISO 4141-2:—¹⁾, *Road vehicles — Multi-core connecting cables — Part 2: Test methods and requirements of high performance sheathed cables*.

ISO 4141-3:—¹⁾, *Road vehicles — Multi-core connecting cables — Part 3: Construction, dimensions and marking of unscreened sheathed low-tension cables*.

3 Dimensions

Unspecified details are to be selected as appropriate.

Pins in sockets and plugs shall be slotted to allow compression over a minimum length of 8,5 mm when plug and socket are engaged.

¹⁾ To be published. (Revision of ISO 4141:1988)

3.2 Plug

See figure 2.

Dimensions in millimetres

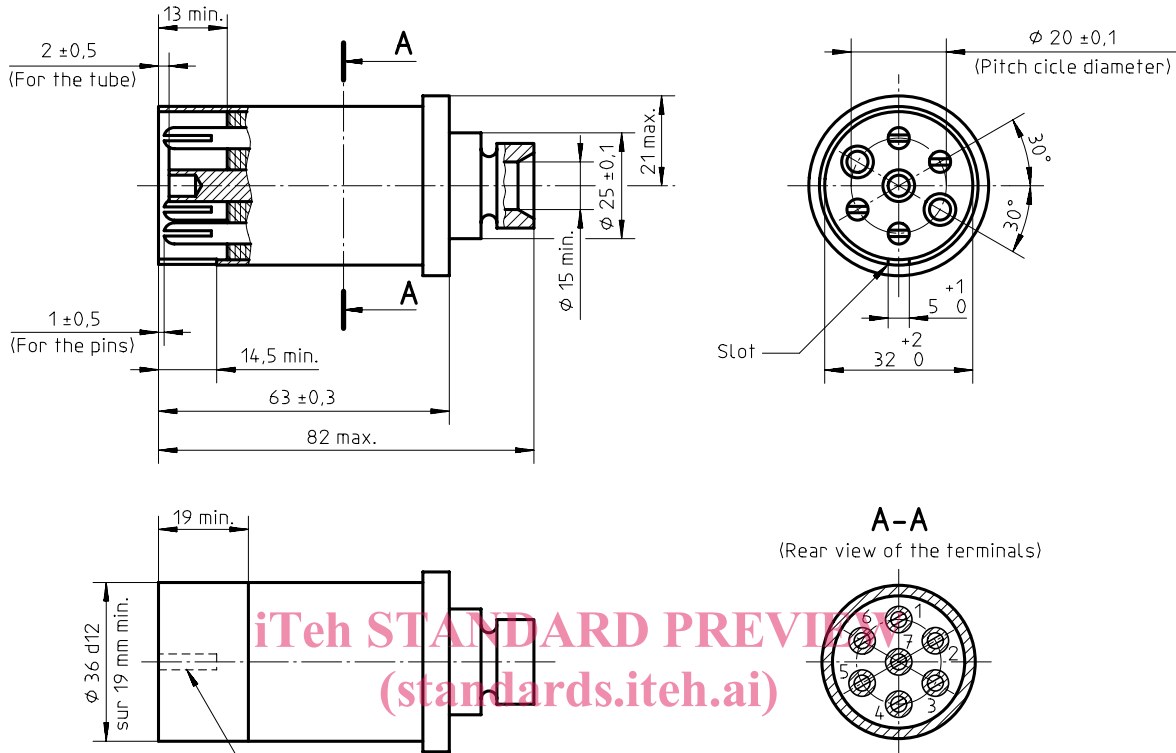

iTeh STANDARD PREVIEW
(standards.iteh.ai)
ISO 1724:1997
<https://standards.iteh.ai/catalog/standards/sist/25fd2a4a-701e-4a32-8f82-a9cf5e335435/iso-1724-1997>

Figure 2 — Plug

The plug shall have four spring pins (Nos. 1, 3, 4, 6) and three tubes (Nos. 2, 5, 7).

The contact numbers shall be permanently marked on the terminal face. The character size shall be not less than 2 mm. Reduced space available may require application of a smaller size on the terminal face.

4 Application of the connector

4.1 Socket and plug position on vehicles

A socket shall be mounted at the rear of a towing vehicle and the position shall comply with the dimensional characteristics necessary for the compatibility of mechanical coupling devices as specified in ISO 1103.

4.2 Free space

The minimum free space for the connector is specified in figure 3.

Dimensions in millimetres

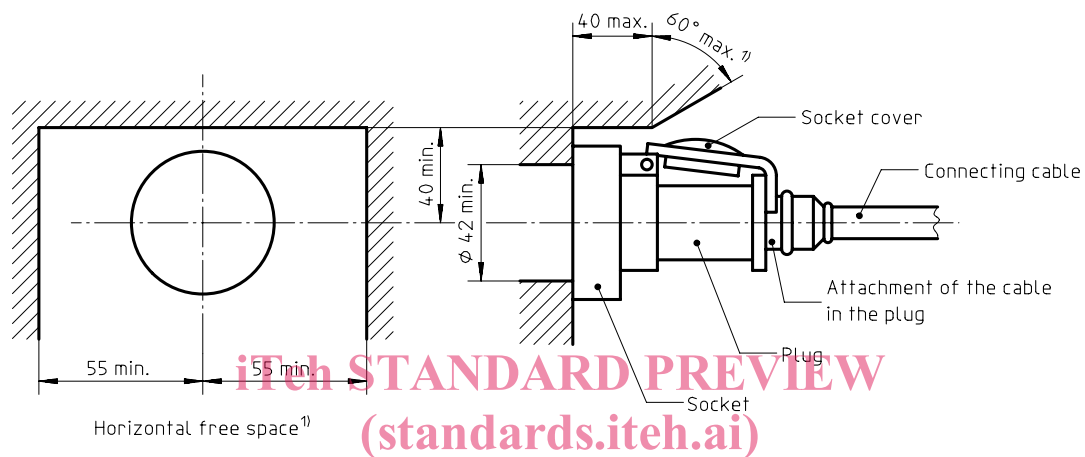

1) The angle of maximum 60 ° shall extend across the horizontal free space.

<https://standards.iteh.ai/catalog/standards/sist/25fd2a4a-701e-4a32-8f82-a9cf5e335435/iso-1724-1997>

4.3 Contact allocation

The allocation of the seven contacts provided shall be as shown in table 1.

Table 1 — Contact allocation

1	Left-hand direction indicator light	yellow
3	Common return	white
4	Right-hand direction indicator light	green
5	Right-hand rear position and marker lights, and rear-registration-plate illumination device ¹⁾	brown
6	Stop lights	red
7	Left-hand rear position and marker lights, and rear-registration-plate illumination device ¹⁾	black

1) The rear-registration-plate illumination device shall be connected in such a manner that no lamp of such a device has a common connection with both contacts 5 and 7.

4.4 Terminals

The terminals at the rear side of the pins and tubes shall be capable of accepting cables with the following nominal cross-sectional areas:

Contact Nos. 1, 2, 4, 5, 6 and 7: 1,5 mm²

Contact No. 3: 2,5 mm²

4.5 Connecting cable

The connecting cable shall meet the requirements of ISO 4141-1, ISO 4141-2 or ISO 4141-3.

4.6 Protection of disconnected plug

A means of storing the plug when disconnected shall be provided on the towed vehicle with the intention of protecting the plug from the ingress of water, foreign bodies and accidental damage.

5 Performance requirements

Connectors shall meet the following requirements.

iTeh STANDARD PREVIEW

5.1 Distinguishing marking **(standards.iteh.ai)**

The 12 N connector shall be distinguished from the 12 S connector in accordance with ISO 3732 by means of different colouring of at least the insulating parts. A dark and permanent colour, preferably black, shall be used for the 12 N connector.

<https://standards.iteh.ai/catalog/standards/sist/25fd2a4a-701e-4a32-8f82-a9cf5e335435/iso-1724-1997>

5.2 Static load

Static load test and performance shall be in accordance with 3.3.1 of ISO 4091:1992.

5.3 Locking device and cable retention

Locking device and cable retention test in accordance with 3.3.2 of ISO 4091:1992 shall be applied to the cable retention only.

Applied force shall be 250 N.

5.4 Insertion and withdrawal forces

Insertion and withdrawal force test shall be in accordance with 3.3.3 of ISO 4091:1992.

The insertion forces shall be 200 N maximum, and the withdrawal force shall be (50 to 200) N³⁾.

5.5 Salt spray

Salt spray test shall be in accordance with 3.3.6 of ISO 4091:1992, but arrangements b) and c) do not apply.

3) Values under consideration.

5.6 Temperature/humidity test

The temperature/humidity test shall be in accordance with 3.3.8 of ISO 4091:1992, with steps d) to g) modified to read:

- d) Lower CT to (-25 ± 2) °C within 2,5 h.
- e) Hold CT at (-25 ± 2) °C for 2 h.
- f) Raise CT to (75 ± 2) °C within 1,5 h.
- g) Hold CT at (75 ± 2) °C for 2 h.

5.7 Lateral strength at low temperature

The lateral strength test shall be in accordance with 3.3.9 of ISO 4091:1992.

5.8 Material specification

Material specifications shall be in accordance with 3.4 of ISO 4091:1992.

5.9 Current carrying capacity

The current carrying capacity test shall be in accordance with 3.5.1 of ISO 4091:1992.

5.10 Voltage drop

The voltage drop test shall be in accordance with 3.5.2 of ISO 4091:1992 and the voltage drop shall not exceed 40 mV.

5.11 Flash test

The flash test shall be in accordance with 3.5.3 of ISO 4091:1992.

5.12 Current cycling test

The current cycling test shall be in accordance with 3.5.4 of ISO 4091:1992.

5.13 Endurance test

The endurance test shall be in accordance with 3.6 of ISO 4091:1992, but with 1 000 cycles as performance.

5.14 Test sequence

Test sequences shall be as given in table 2.

The test sequences shall be carried out in the order of the running numbers listed in table 2 under the particular sample group. A test sequence shall be continued only if a sample meets the appropriate requirements.

Table 2 — Test sequences

Reference subclause	Test title	Sample group				
		A	B	C	D	E
3.2 ¹⁾	Visual examination	1	1	1	1	1
4.2 ¹⁾	Dimensional check	2				
5.4	Insertion	3	2	2	2	2
5.3	Locking device and cable retention	4	3 9		3 8	3 8
5.2	Static load	5				
5.7	Lateral strength at low temperature	6				
5.10	Voltage drop		4 7	3 6	4 7	4 7
5.6	Temperature/humidity test		6			
5.5	Salt spray				5	
5.11	Flash test		5 8		6	5 10
5.9	Current carrying capacity			4		
5.12	Current cycling			5		
5.13	Endurance test					6
5.4	Withdrawal	7	10	7	9	9

1) Subclause of ISO 4091:1992.

<https://standards.iteh.ai/catalog/standards/sist/25fd2a4a-701e-4a32-8f82-a9cf5e335435/iso-1724-1997>
 ISO 1724:1997
 (standards.iteh.ai)