



Standard Test Method for Smoldering Combustion Potential of Cotton-Based Batting¹

This standard is issued under the fixed designation D 5238; the number immediately following the designation indicates the year of original adoption or, in the case of revision, the year of last revision. A number in parentheses indicates the year of last reapproval. A superscript epsilon (ϵ) indicates an editorial change since the last revision or reapproval.

1. Scope

1.1 This test method covers the determination of smoldering combustion potential within cotton-based batting intended for use in mattresses and upholstered furniture. This test method should not be used to evaluate batting containing less than 75 % cotton by weight, and it is intended to be used primarily as a quality control tool.

1.2 This test method should be used to measure and describe the properties of materials, products, or assemblies in response to heat and flame under controlled laboratory conditions and should not be used to describe or appraise the fire hazard or risk of materials, products, or assemblies under actual fire conditions. However, the results of this test may be used as elements of a fire risk assessment that takes into account all of the factors that are pertinent to an assessment of the fire hazard of a particular end use.

1.3 Inadequate consideration of a subsystem, such as cotton batting, to resist smoldering is frequently the reason that finish systems fail fire and smolder resistance tests in mattresses and upholstered furniture. This test method may be used to evaluate this smolder resistance in the subsystem of cotton batting used in such products. The purpose of this test method is to aid end users in better determining the potential of cotton batting components to resist smoldering. It is recommended that those using this test method be familiar with cotton batting production and the use of cotton batting in mattresses and upholstered furniture.

1.4 The values stated in SI units are to be regarded as the standard. The values given in parentheses are for information only.

1.5 *This standard does not purport to address all of the safety concerns, if any, associated with its use. It is the responsibility of the user of this standard to establish appropriate safety and health practices and determine the applicability of regulatory limitations prior to use.*

2. Referenced Documents

2.1 ASTM Standards:

D 123 Terminology Relating to Textile Materials²

D 1776 Practice for Conditioning Textiles for Testing²

¹ This test method is under the jurisdiction of ASTM Committee D-13 on Textiles and is the direct responsibility of Subcommittee D13.52 on Flammability.

Current edition approved Sept. 10, 1998. Published December 1998. Originally published as D 5238 – 92. Last previous edition D 5238 – 92.

² *Annual Book of ASTM Standards*, Vol 07.01.

D 2258 Recommended Practice for Sampling Yarn for Testing²

D 4391 Terminology Relating to the Burning Behavior of Textiles³

E 176 Terminology Relating to Fire Standards⁴

2.2 *Government Standard:*

16 CFR Part 1632, Standard for the Flammability of Mattresses and Mattress Pads (FF 4-72 Amended)⁵

3. Terminology

3.1 *Definitions*—For definitions of terms relating to burning behavior, refer to Terminology D 4391. For definitions of other textile terms, refer to Terminology D 123.

3.2 *Description of Term Specific to This Standard:*

3.2.1 *batting, n*—a textile filling material consisting of a continuous web of fibers formed by carding, garnetting, air layering, or other means.

3.2.1.1 *Discussion*—In the bedding, furniture, and futon industries, batting is made from a blend of fibers consisting primarily of cotton.

4. Summary of Test Method

4.1 A controlled heat source is positioned between two identical specimens of cotton batting. The heat source and specimens remain undisturbed until the specimens either are consumed or are no longer undergoing smoldering combustion. The resulting outward char distance from the initial heat source is determined.

5. Significance and Use

5.1 This test method provides a means for evaluating the smoldering combustion potential of cotton-based batting for use in mattresses and upholstered furniture. The degree of correlation between the results of this test of a component material and actual end-use products has not been determined fully.

5.2 In this procedure, the specimens are subjected to one or more specific sets of laboratory test conditions. If different test conditions are substituted or the end-use conditions are changed, it may not be possible by or from this test method to predict changes in the fire test response characteristics measured. The results are therefore valid only for the fire test

³ *Annual Book of ASTM Standards*, Vol 07.02.

⁴ *Annual Book of ASTM Standards*, Vol 04.07.

⁵ *Federal Register*; Vol 49, No. 197, Wednesday, October 10, 1984.

exposure conditions described in this procedure.

5.3 In the case of a dispute arising from differences in the reported test results using this test method for acceptance testing of commercial shipments, the purchaser and the supplier should conduct comparative tests to determine whether a statistical bias exists between their laboratories. Competent statistical assistance is recommended for the investigation of bias. As a minimum, the two parties should take a group of test specimens that are as homogeneous as possible and that are from a lot of material of the type in question. The test specimens should then be randomly assigned in equal numbers to each laboratory for testing. The average results from the two laboratories should be compared using Student's *t*-test for unpaired data and an acceptable probability level chosen by the two parties before testing began. If a bias is found, either its cause must be determined and corrected, or the purchaser and supplier must agree to interpret future test results in light of the known bias.

6. Apparatus and Materials

6.1 *Balance*, 200-g capacity open pan, with 0.1-g sensitivity.

6.2 *Draft Barrier*, as shown in Fig. 1.

6.3 *Test Room*, draft-protected and equipped with a suitable system for exhausting combustion emissions produced during testing.

6.4 *Heat Source*—Pall Mall cigarettes without filters or equal, each measuring 85 ± 2 mm (3.4 ± 0.1 in.) in length and weighing 1.1 ± 0.1 g.

6.5 *Ruler*—Standard 6-in. (152-mm) ruler.

7. Sampling

7.1 *Lot Sample*—Take a lot sample as specified in the applicable material specification, or as agreed upon by the two parties interested in the test results. In the absence of any specification or agreement, take a lot sample as directed in Recommended Practice D 2258.

7.2 *Laboratory Sample*—As a laboratory sample for acceptance testing, take at random the number of packages from each primary sampling unit in the lot sample directed in an applicable material specification or other agreement between the purchaser and the supplier, such as an agreement to use Recommended Practice D 2258. Sample packages should not be rewound or transferred to another package.

8. Preparation of Specimens

8.1 Prepare two adjacent 18 by 18 ± 1 -cm (7 by 7 $\pm 1/4$ -in.) specimens of cotton-based batting and one cigarette in triplicate for each test.

8.2 Weigh and record the initial weights of each specimen. Each cotton-based specimen may weigh not less than 54 g (1.9 oz) and not more than 57 g (2 oz).

9. Conditioning

9.1 If the as-received sample has a moisture content above 10 %, follow the preconditioning and conditioning procedures as specified in Practice D 1776 prior to testing.

9.2 It has been found that samples having a moisture content of 10 % and below do not materially affect the results of this test method, and therefore no preconditioning or conditioning is required.

10. Procedure

10.1 On a wooden sheet having dimensions of 20 by 20 by 1.3 cm (8 by 8 by 0.5 in.), position one specimen as shown in Fig. 2.

10.2 *Test Start-Up*:

10.2.1 Within 5 min of the initial weighing, light one cigarette, centering it on the surface of the positioned specimen, and record the time.

APPENDIX

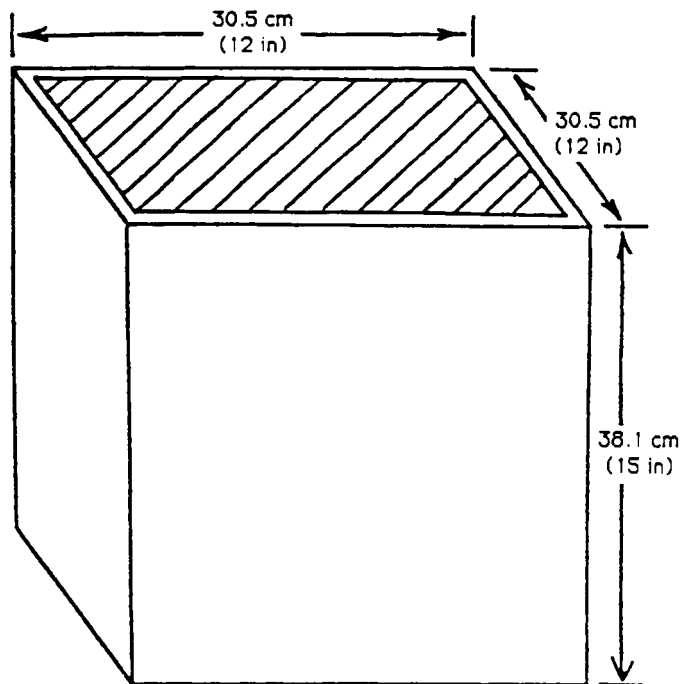

FIG. 1 Draft Barrier

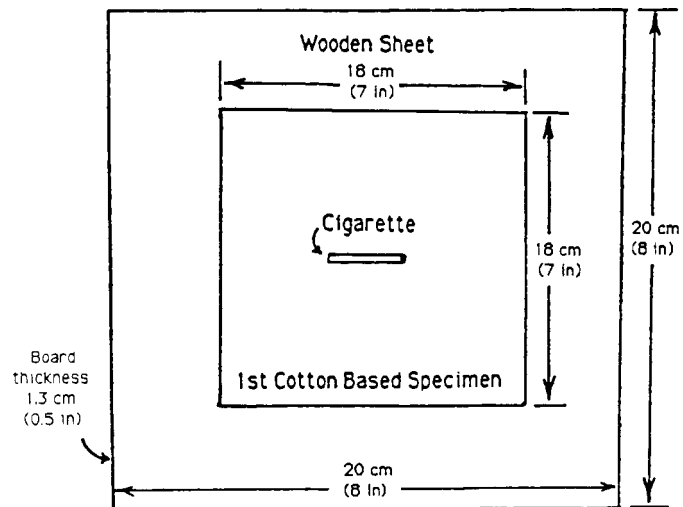

FIG. 2 Positioned Specimen