**Optics and photonics — Preparation
of drawings for optical elements and
systems —**

**Part 9:
Surface treatment and coating**

iTeh STANDARD PREVIEW
*Optique et photonique — Indications sur les dessins pour éléments et
systèmes optiques —
(standards.iteh.ai)
Partie 9: Traitement de surface et revêtement*

[ISO 10110-9:2016](https://standards.iteh.ai/catalog/standards/sist/2807ce5b-f672-403d-a5a6-762d9af11a32/iso-10110-9-2016)

<https://standards.iteh.ai/catalog/standards/sist/2807ce5b-f672-403d-a5a6-762d9af11a32/iso-10110-9-2016>



iTeh STANDARD PREVIEW
(standards.iteh.ai)

ISO 10110-9:2016

<https://standards.iteh.ai/catalog/standards/sist/2807ce5b-f672-403d-a5a6-762d9af11a32/iso-10110-9-2016>



COPYRIGHT PROTECTED DOCUMENT

© ISO 2016, Published in Switzerland

All rights reserved. Unless otherwise specified, no part of this publication may be reproduced or utilized otherwise in any form or by any means, electronic or mechanical, including photocopying, or posting on the internet or an intranet, without prior written permission. Permission can be requested from either ISO at the address below or ISO's member body in the country of the requester.

ISO copyright office
Ch. de Blandonnet 8 • CP 401
CH-1214 Vernier, Geneva, Switzerland
Tel. +41 22 749 01 11
Fax +41 22 749 09 47
copyright@iso.org
www.iso.org

Contents

	Page
Foreword	iv
1 Scope	1
2 Normative references	1
3 Terms and definitions	1
4 General	1
5 Indications in drawings	2
5.1 General	2
5.2 Indication of functional coatings	2
5.3 Indication of protective treatments	3
6 Imperfections of functional coatings	3
7 Examples	3
Annex A (informative) Functional coatings (from ISO 9211-1:2010)	5
Annex B (informative) Example for an optical drawing using the indication of functional coatings in tabular form	6
Annex C (informative) Example for a coating specification document	7
Annex D (informative) Example of a functional coating indication showing two different coatings on the same surface	8
Bibliography	9

ITeH STANDARD PREVIEW
(standards.iteh.ai)

[ISO 10110-9:2016](https://standards.iteh.ai/catalog/standards/sist/2807ce5b-f672-403d-a5a6-762d9af11a32/iso-10110-9-2016)

<https://standards.iteh.ai/catalog/standards/sist/2807ce5b-f672-403d-a5a6-762d9af11a32/iso-10110-9-2016>

Foreword

ISO (the International Organization for Standardization) is a worldwide federation of national standards bodies (ISO member bodies). The work of preparing International Standards is normally carried out through ISO technical committees. Each member body interested in a subject for which a technical committee has been established has the right to be represented on that committee. International organizations, governmental and non-governmental, in liaison with ISO, also take part in the work. ISO collaborates closely with the International Electrotechnical Commission (IEC) on all matters of electrotechnical standardization.

The procedures used to develop this document and those intended for its further maintenance are described in the ISO/IEC Directives, Part 1. In particular the different approval criteria needed for the different types of ISO documents should be noted. This document was drafted in accordance with the editorial rules of the ISO/IEC Directives, Part 2 (see www.iso.org/directives).

Attention is drawn to the possibility that some of the elements of this document may be the subject of patent rights. ISO shall not be held responsible for identifying any or all such patent rights. Details of any patent rights identified during the development of the document will be in the Introduction and/or on the ISO list of patent declarations received (see www.iso.org/patents).

Any trade name used in this document is information given for the convenience of users and does not constitute an endorsement.

For an explanation on the meaning of ISO specific terms and expressions related to conformity assessment, as well as information about ISO's adherence to the WTO principles in the Technical Barriers to Trade (TBT) see the following URL: [Foreword - Supplementary information](#)

The committee responsible for this document is ISO/TC 172, *Optics and photonics*, Subcommittee SC 1, *Fundamental standards*.

This second edition cancels and replaces the first edition (ISO 10110-9:1996), which has been technically revised with the following changes:

- a) the referencing of optical coating standards ISO 9211-1 and ISO 9211-2;
- b) the description of functional coatings in tabular form as described in ISO 10110-1;
- c) a complete revision of all drawings;
- d) the addition of [Annexes A to D](#) which show examples for optical drawings and coating specification documents.

ISO 10110 consists of the following parts, under the general title *Optics and photonics — Preparation of drawings for optical elements and systems*:

- *Part 1: General*
- *Part 2: Material imperfections — Stress birefringence*
- *Part 3: Material imperfections — Bubbles and inclusions*
- *Part 4: Material imperfections — Inhomogeneity and striae*
- *Part 5: Surface form tolerances*
- *Part 6: Centring tolerances*
- *Part 7: Surface imperfection tolerances*
- *Part 8: Surface texture; roughness and waviness*
- *Part 9: Surface treatment and coating*

- *Part 10: Table representing data of optical elements and cemented assemblies*
- *Part 11: Non-toleranced data*
- *Part 12: Aspheric surfaces*
- *Part 14: Wavefront deformation tolerance*
- *Part 17: Laser irradiation damage threshold*
- *Part 19: General description of surfaces and components*

iTeh STANDARD PREVIEW
(standards.iteh.ai)

[ISO 10110-9:2016](https://standards.iteh.ai/catalog/standards/sist/2807ce5b-f672-403d-a5a6-762d9af11a32/iso-10110-9-2016)

<https://standards.iteh.ai/catalog/standards/sist/2807ce5b-f672-403d-a5a6-762d9af11a32/iso-10110-9-2016>

iTeh STANDARD PREVIEW
(standards.iteh.ai)

ISO 10110-9:2016

<https://standards.iteh.ai/catalog/standards/sist/2807ce5b-f672-403d-a5a6-762d9af11a32/iso-10110-9-2016>

Optics and photonics — Preparation of drawings for optical elements and systems —

Part 9: Surface treatment and coating

1 Scope

ISO 10110 specifies the presentation of design and functional requirements for optical elements and systems in technical drawings used for manufacturing and inspection.

This part of ISO 10110 specifies rules for indicating the treatments and coatings applied to optical surfaces for functional and/or protective purposes.

2 Normative references

The following documents, in whole or in part, are normatively referenced in this document and are indispensable for its application. For dated references, only the edition cited applies. For undated references, the latest edition of the referenced document (including any amendments) applies.

ISO 128-24, *Technical drawings — General principles of presentation — Part 24: Lines on mechanical engineering drawings*

ISO 9211-1:2010, *Optics and photonics — Optical coatings — Part 1: Definitions*

ISO 9211-2, *Optics and photonics — Optical coatings — Part 2: Optical properties*

3 Terms and definitions

For the purposes of this document, the terms and definitions given in ISO 9211-1 and the following apply.

3.1 functional coating

thin film deposited to affect surface reflectance, to separate spectral wavelength regions, and/or to produce certain polarization or other special properties

Note 1 to entry: There is a wide variety of functional coatings, e.g. reflective, antireflective, wavelength selective, conductive or protective coatings. The different types of functional coatings are listed in ISO 9211-1:2010, Table A.1 (see [Annex A](#)).

3.2 protective surface treatment

paint or plating protection applied to optical surfaces, particularly rear surface mirrors, to prevent damage from handling, environmental effects and other causes

Note 1 to entry: Surfaces may also be painted or covered in certain areas to limit their optically effective apertures for stray light control.

4 General

ISO 10110-1 stipulates that all indications apply fundamentally to the finished product. Accordingly, the dimensions given in drawings which mention surface treatments or coatings refer to the dimensions after application of the treatments or coatings (see [Figure 1](#)). However, in certain cases, the dimensions

of a part before the application of surface treatments might be important. In such cases, it shall be explicitly indicated in the drawing that these dimensions refer to the untreated part.

5 Indications in drawings

5.1 General

The form of the specification for coatings is defined in ISO 9211-2.

When coating performance requirements are complex, they are described in separate specification documents, which shall be referenced in the drawings. If the specification is simple, it may be given directly on the drawing. In this case, the following symbols shall be used according to ISO 9211-1:

- $\tau(\lambda)$ for spectral transmittance;
- $\rho(\lambda)$ for spectral reflectance;
- $\alpha(\lambda)$ for spectral absorptance.

NOTE Wherever the Greek letters are mistakable, $T(\lambda)$, $R(\lambda)$ and $A(\lambda)$ can be used.

Wavelengths shall be given in nanometers.

5.2 Indication of functional coatings

For a suitable optical element, especially a lens element or a prism, the data may be given in tabular form as described in ISO 10110-1. The preferred field for the indication of functional coatings is the table field. An example is shown in [Annex B](#).

If the specification of a coating is too long to be included in the appropriate table field, it shall be given in the drawing field in a box as described below or in a separate coating specification document. An example is shown in [Annex C](#).

Functional coatings shall be indicated by λ . If functional coatings are specified in the table field, this symbol shall be located at the beginning of the specification. When functional coatings are specified in the drawing field, this symbol shall be located outside the element and tangent to the surface to be coated. Exceptions are elements in which the coating is protected by a protective layer and cemented (or optically contacted) subassemblies; in these cases, the coating symbol shall be placed inside the optical element (see [Figure 2](#) and [Figure 3](#)).

In drawings of a subassembly, the position of the coating symbol, λ , indicates to which of the two joined surfaces the coating is to be deposited: the coating symbol is placed inside the optical element that is to be coated prior to assembly (see [Figure 3](#)).

The coating symbol shall have a leader line to a box, containing the specification reference or specification.

Examples are given in [Figures 2](#) to [5](#).

The function of the coating shall be included in the box. Unless otherwise noted, the specifications shall refer to the indicated surface alone. In the case of functional coatings that are to be cemented, it shall be indicated whether the specification applies before or after cementing (see [Figure 3](#)).

Unless indicated otherwise, the coating shall extend at least over the optically effective surface. If necessary, toleranced dimensions shall be given for the area to be coated. In cases in which different zones of the same surface are to be coated differently, the zones shall be indicated by dimensioning (see [Annex D](#)).

5.3 Indication of protective treatments

Surface treatment such as protective treatments shall be indicated by a thick “chain” line (line type 04.2, ISO 128-24) adjacent to the surface. The length of this line indicates the region to be treated. If necessary, dimensions shall be given for this region.

The specification of the surface treatment shall be given in a box, which is connected to the thick “chain” line by a leader. Examples are given in [Figures 1](#) and [2](#).

6 Imperfections of functional coatings

ISO 10110-7 specifies the indication of an acceptability level for coating imperfections, which are described in ISO 9211-1.

7 Examples

Examples of functional coating and protective surface treatment indications are given in [Figures 1](#) to [5](#).

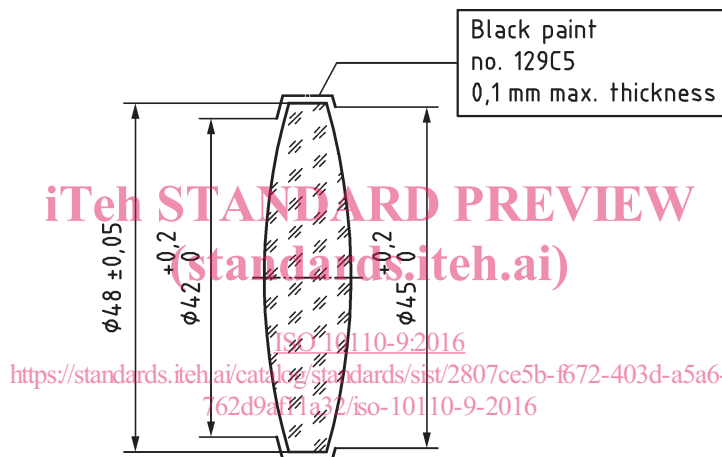

Figure 1 — Example of protective surface treatment indication (the outer diameter of 48 mm \pm 0,05 mm refers to the part after painting)

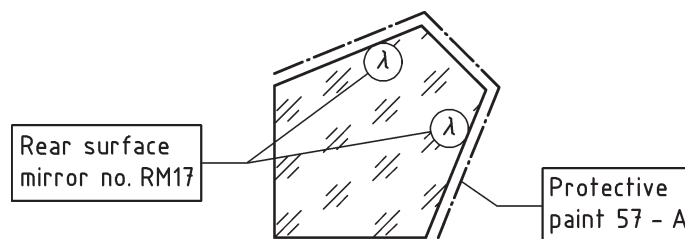

Figure 2 — Example of indication of a protective surface treatment combined with a functional coating