**Cutting tool data representation and
exchange —**

**Part 204:
Creation and exchange of 3D models
— Inserts for reaming**

*Représentation et échange des données relatives aux outils coupants —
Partie 204: Création et échange de modèles 3D — Plaquettes pour
l'alésage*

iTeh STANDARD PREVIEW
(standards.iteh.ai/catalog/standards/sist/13399-204/iso/13399-204-2015)
Full standard:
<https://standards.iteh.ai/catalog/standards/sist/13399-204/iso/13399-204-2015>
d08b-40ba-ac0b-1070b6a9335c/iso/13399-204-2015

PROOF / ÉPREUVE



iTeh STANDARD PREVIEW
(standards.iteh.ai)
Full standard:
<https://standards.iteh.ai/catalog/standards/sist/5369a351-d08b-40ba-ae0b-1070b6a9335c/iso-ts-13399-204-2016>



COPYRIGHT PROTECTED DOCUMENT

© ISO 2015, Published in Switzerland

All rights reserved. Unless otherwise specified, no part of this publication may be reproduced or utilized otherwise in any form or by any means, electronic or mechanical, including photocopying, or posting on the internet or an intranet, without prior written permission. Permission can be requested from either ISO at the address below or ISO's member body in the country of the requester.

ISO copyright office
Ch. de Blandonnet 8 • CP 401
CH-1214 Vernier, Geneva, Switzerland
Tel. +41 22 749 01 11
Fax +41 22 749 09 47
copyright@iso.org
www.iso.org

Contents

Page

Foreword	iv
Introduction	vi
1 Scope	1
2 Normative references	1
3 Starting elements, coordinate systems, planes	1
3.1 General.....	1
3.2 Reference system.....	2
3.3 Coordinate systems.....	2
3.3.1 General.....	2
3.3.2 Coordinate system for the location of the insert.....	2
3.3.3 Coordinate system for the mounting of the insert.....	3
3.4 Planes.....	3
4 Design of the model	4
5 Reaming insert with one cutting edge and double plug chamfer	4
5.1 General.....	4
5.2 Necessary properties.....	4
5.3 Basic geometry.....	5
5.4 Detailed geometry.....	5
6 Reaming insert with two cutting edges and double plug chamfer	6
6.1 General.....	6
6.2 Necessary properties.....	6
6.3 Basic geometry.....	7
6.4 Detailed geometry.....	7
7 Reaming insert with one cutting edge and rounded corner	8
7.1 General.....	8
7.2 Necessary properties.....	8
7.3 Basic geometry.....	9
7.4 Detailed geometry.....	9
8 Reaming insert with two cutting edges and rounded corner	10
8.1 General.....	10
8.2 Necessary properties.....	10
8.3 Basic geometry.....	10
8.4 Detailed geometry.....	10
9 Reaming insert with special cutting profile	11
9.1 General.....	11
9.2 Necessary properties.....	11
9.3 Basic geometry.....	12
9.4 Detailed geometry.....	12
10 Attributes of surfaces — Visualization of the model features	12
11 Structure of the design elements (tree of model)	12
11.1 General.....	12
11.2 Example of the structure of the design elements.....	12
12 Data exchange model	13
Annex A (informative) Information about nominal dimensions	14
Bibliography	15

Foreword

ISO (the International Organization for Standardization) is a worldwide federation of national standards bodies (ISO member bodies). The work of preparing International Standards is normally carried out through ISO technical committees. Each member body interested in a subject for which a technical committee has been established has the right to be represented on that committee. International organizations, governmental and non-governmental, in liaison with ISO, also take part in the work. ISO collaborates closely with the International Electrotechnical Commission (IEC) on all matters of electrotechnical standardization.

The procedures used to develop this document and those intended for its further maintenance are described in the ISO/IEC Directives, Part 1. In particular the different approval criteria needed for the different types of ISO documents should be noted. This document was drafted in accordance with the editorial rules of the ISO/IEC Directives, Part 2 (see www.iso.org/directives).

Attention is drawn to the possibility that some of the elements of this document may be the subject of patent rights. ISO shall not be held responsible for identifying any or all such patent rights. Details of any patent rights identified during the development of the document will be in the Introduction and/or on the ISO list of patent declarations received (see www.iso.org/patents).

Any trade name used in this document is information given for the convenience of users and does not constitute an endorsement.

For an explanation on the meaning of ISO specific terms and expressions related to conformity assessment, as well as information about ISO's adherence to the WTO principles in the Technical Barriers to Trade (TBT) see the following URL: [Foreword - Supplementary information](#)

The committee responsible for this document is ISO/TC 29, *Small tools*.

ISO/TS 13399 consists of the following parts, under the general title *Cutting tool data representation and exchange*:

- *Part 1: Overview, fundamental principles and general information model*
- *Part 2: Reference dictionary for the cutting items* [Technical Specification]
- *Part 3: Reference dictionary for tool items* [Technical Specification]
- *Part 4: Reference dictionary for adaptive items* [Technical Specification]
- *Part 5: Reference dictionary for assembly items* [Technical Specification]
- *Part 50: Reference dictionary for reference systems and common concepts* [Technical Specification]
- *Part 60: Reference dictionary for connection systems* [Technical Specification]
- *Part 80: Creation and exchange of 3D models — Overview and principles* [Technical Specification]
- *Part 100: Definitions, principles and methods for reference dictionaries* [Technical Specification]
- *Part 150: Usage guidelines* [Technical Specification]
- *Part 201: Creation and exchange of 3D models — Regular inserts* [Technical Specification]
- *Part 202: Creation and exchange of 3D models — Irregular inserts* [Technical Specification]
- *Part 203: Creation and exchange of 3D models — Replaceable inserts for drilling* [Technical Specification]
- *Part 204: Creation and exchange of 3D models — Inserts for reaming* [Technical Specification]
- *Part 301: Concept for the design of 3D models based on properties according to ISO/TS 13399-3: Modelling of thread-cutting taps, thread-forming taps and thread-cutting dies* [Technical Specification]

- *Part 302: Concept for the design of 3D models based on properties according to ISO/TS 13399-3: Modelling of solid drills and countersinking tools* [Technical Specification]

The following parts are under preparation:

- *Part 51: Designation system for customer solution cutting tools* [Technical Specification]
- *Part 70: Graphical data layout — Layer settings for tool designs* [Technical Specification]
- *Part 71: Graphical data layout — Creation of documents for the standardized data exchange — Graphical product information* [Technical Specification]
- *Part 72: Creation of documents for the standardized data exchange — Definition of properties for drawing header and their XML-data exchange* [Technical Specification]
- *Part 303: Concept for the design of 3D models based on properties according to ISO/TS 13399-3: Modelling of end mills with solid cutting edges* [Technical Specification]
- *Part 304: Concept for the design of 3D models based on properties according to ISO/TS 13399-3: Modelling of milling cutters with arbor hole and solid cutting edges* [Technical Specification]
- *Part 307: Creation and exchange of 3D models — End mills for indexable inserts* [Technical Specification]
- *Part 308: Creation and exchange of 3D models — Milling cutter with arbor hole for indexable inserts* [Technical Specification]
- *Part 309: Creation and exchange of 3D models — Tool holders for indexable inserts* [Technical Specification]
- *Part 311: Creation and exchange of 3D models — Solid reamers* [Technical Specification]
- *Part 312: Creation and exchange of 3D models — Reamers for indexable inserts* [Technical Specification]
- *Part 401: Creation and exchange of 3D models — Converting, extending and reducing adaptive items* [Technical Specification]
- *Part 405: Creation and exchange of 3D models — Collets* [Technical Specification]

Introduction

This part of ISO 13399 defines the concept, terms and definitions regarding the creation and exchange of simplified 3D models of inserts for reaming that can be used with 3D models of cutting tools for NC-programming, simulation of manufacturing processes and the collision determination within machining processes. It is not intended to standardize the design of the insert for reaming itself, nor the cutting tool.

An insert for reaming is used in combination with a cutting tool in a machine to remove material from a workpiece by a shearing action at the cutting edges of the tool. Cutting tool data that can be described by ISO 13399 include, but are not limited to, everything between the workpiece and the machine tool. Information about inserts, solid tools, assembled tools, adaptors, components and their relationships can be represented by this part of ISO 13399. The increasing demand for providing the end user with 3D models for the purposes defined above is the basis for the development of this series of International Standards.

The objective of this International Standard is to provide the means to represent the information that describes cutting tools in a computer sensible form that is independent from any particular computer system. The representation will facilitate the processing and exchange of cutting tool data within and between different software systems and computer platforms and support the application of this data in manufacturing planning, cutting operations and the supply of tools. The nature of this description makes it suitable not only for neutral file exchange, but also as a basis for implementing and sharing product databases and for archiving. The methods that are used for these representations are those developed by ISO/TC 184/SC 4 for the representation of product data by using standardized information models and reference dictionaries.

Definitions and identifications of dictionary entries are defined by means of standard data that consist of instances of the EXPRESS entity data types defined in the common dictionary schema, resulting from a joint effort between ISO/TC 184/SC 4 and IEC/TC 3/SC 3D, and in its extensions defined in ISO 13584-24 and ISO 13584-25.

Cutting tool data representation and exchange —

Part 204:

Creation and exchange of 3D models — Inserts for reaming

1 Scope

This part of ISO 13399 specifies a concept for the design of cutting items, limited to any kind of replaceable inserts for reaming, using related properties and domains of values.

This part of ISO 13399 specifies a common way of designing simplified models that contain the following:

- definitions and identification of the design features of replaceable inserts for reaming, with a link to the properties used;
- definitions and identification of the internal structure of the 3D model that represents the features and the properties of replaceable inserts for reaming;

The following are outside the scope of this part of ISO 13399:

- applications where these standard data may be stored or referenced;
- creation and exchange of simplified 3D models for cutting tools;
- creation and exchange of simplified 3D models for tool items;
- creation and exchange of simplified 3D models for other cutting items not described in this part of ISO 13399;
- creation and exchange of simplified 3D models for adaptive items;
- creation and exchange of simplified 3D models for assembly items and auxiliary items.

2 Normative references

The following documents, in whole or in part, are normatively referenced in this document and are indispensable for its application. For dated references, only the edition cited applies. For undated references, the latest edition of the referenced document (including any amendments) applies.

ISO/TS 13399-2, *Cutting tool data representation and exchange — Part 2: Reference dictionary for the cutting items.*

ISO/TS 13399-80, *Cutting tool data representation and exchange — Part 80: Creation and exchange of 3D models — Overview and principles*

3 Starting elements, coordinate systems, planes

3.1 General

The creation of 3D models shall be done by means of nominal dimensions.

WARNING — There is no guarantee that the 3D model, created according to the methods described in this part of ISO 13399, is a true representation of the physical tool supplied by the tool

manufacturer. If the models are used for simulation purposes, e.g. CAM simulation, it shall be taken into consideration that the real product dimensions can differ from those nominal dimensions.

NOTE Some of the definitions have been taken from ISO/TS 13399-50.

3.2 Reference system

The reference system consists of the following standard elements:

- **standard coordinate system:** right-handed rectangular Cartesian system in three dimensional space, called primary coordinate system (PCS);
- **three orthogonal planes:** planes in the coordinate system that contain the axes of the system, named XY plane (XYP), XZ plane (XZP) and YZ plane (YZP);
- **three orthogonal axes:** axes built as intersections of the three orthogonal plane lines respectively, named X axis (XA), Y axis (YA) and Z axis (ZA).

3.3 Coordinate systems

3.3.1 General

In principle, an insert has two coordinate systems:

- the primary coordinate system, which determines the position of the insert in the space;
- the secondary coordinate system that helps to mount the insert on to a tool body.

3.3.2 Coordinate system for the location of the insert

The coordinate system primary coordinate system (PCS), shown in [Figure 1](#), defines the position of the insert in the space. The determinations are the following:

- the insert is located in the XY quadrant;
- the cutting edges are collinear with the XY plane;
- the major cutting edge is collinear with the positive X axis;
- the theoretical sharp cutting point is on the Y axis;
- the direction of the insert thickness is parallel to the negative Z axis.

These determinations are valid for right handed or neutral inserts. Left-handed inserts shall be mirrored through the YZ plane.

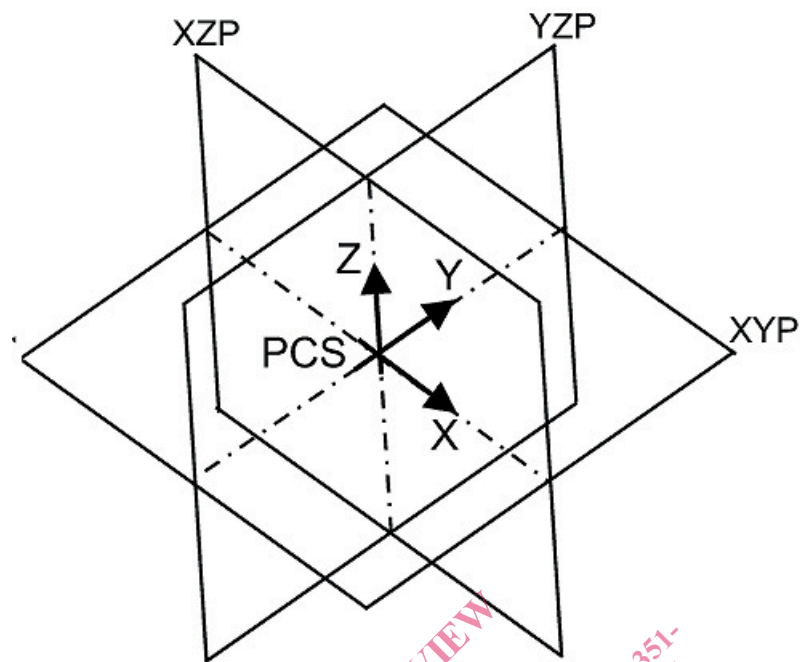

Figure 1 — Reference system PCS

3.3.3 Coordinate system for the mounting of the insert

The reference coordinate system mounting coordinate system (MCS) is placed on the XY-plane of the PCS with the same orientation as the PCS, as in Figure 2, with the following determinations:

- the X-axis of MCS (MXA) shall be colinear to the X-axis of PCS (XA);
- the Y-axis of MCS (MYA) shall be colinear to the Y-axis of PCS (YA);
- the Z-axis of MCS (MZA) shall be colinear to the Z-axis of PCS (ZA).

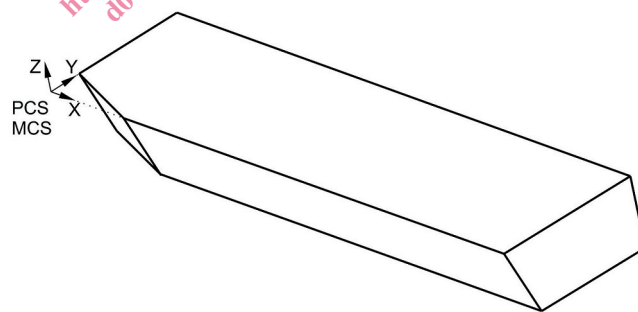

Figure 2 — Mounting coordinate system (MCS)

3.4 Planes

To distinguish between the PCS and the MCS planes, the MCS planes shall be given the prefix “M”:

- XYP (PCS) → MXYP (MCS);
- XZP (PCS) → MXZP (MCS);
- YZP (PCS) → MYZP (MCS).

4 Design of the model

The sketches (outline contour) and features of the basic model shall not contain details such as chip breakers, face land geometry or tipped cutting parts made of other cutting materials. Those features shall be designed as separate design elements after the basic geometry and shall be grouped as detail geometry, as described in 5.4.

The structure and sequence of the modelling shall be kept as described. The defined preferred symbols shall be taken as names for the variables.

The models of the regular inserts shall contain the following design features:

- basic geometry;
- corner configuration geometry;
- mounting geometry.

The total amount of design features will be dependent on the desired level of modelling and the complexity of the inserts.

Within 3D CAD systems, the specified model structure of the basic shapes of the inserts is described in Clauses 5 to 9.

5 Reaming insert with one cutting edge and double plug chamfer

5.1 General

Figure 3 shows the properties used for identification and classification of reaming insert with one cutting edge and double plug chamfer.

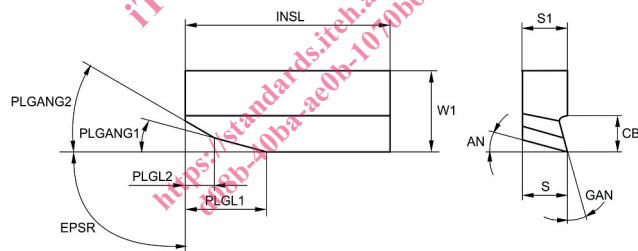

Figure 3 — Determination of properties for reaming inserts with one cutting edge and double plug chamfer

5.2 Necessary properties

Table 1 shows the properties needed for the modelling of a reaming insert with one cutting edge and double plug chamfer.

Table 1 — Properties for the modelling of reaming inserts with one cutting edge and double plug chamfer

Preferred name	Preferred symbol
Clearance angle major cutting edge	AN
Clearance angle minor cutting edge	ANN
Chip breaker length	CBL
Insert included angle	EPSR