



Designation: D5160 – 95(Reapproved 2008)

Standard Guide for Gas-Phase Adsorption Testing of Activated Carbon¹

This standard is issued under the fixed designation D5160; the number immediately following the designation indicates the year of original adoption or, in the case of revision, the year of last revision. A number in parentheses indicates the year of last reapproval. A superscript epsilon (ϵ) indicates an editorial change since the last revision or reapproval.

1. Scope

1.1 This guide covers the evaluation of activated carbons for gas-phase adsorption. It presents a procedure for determining the dynamic adsorption capacity, N_o , and critical bed depth, d_c , for an activated carbon used to remove a specific adsorbate from a gas stream under conditions chosen by the user.

1.2 The values stated in SI units are to be regarded as standard. No other units of measurement are included in this standard.

1.3 *This standard does not purport to address all of the safety concerns, if any, associated with its use. It is the responsibility of the user of this standard to establish appropriate safety and health practices and determine the applicability of regulatory limitations prior to use.* Specific hazards statements are given in Section 8.

2. Referenced Documents

2.1 *ASTM Standards:*²

D2652 Terminology Relating to Activated Carbon

D2854 Test Method for Apparent Density of Activated Carbon

D2867 Test Methods for Moisture in Activated Carbon

D3467 Test Method for Carbon Tetrachloride Activity of Activated Carbon

E300 Practice for Sampling Industrial Chemicals

3. Terminology

3.1 *Definitions:*

3.1.1 *breakthrough*—the appearance in the effluent of a specified concentration of an adsorbate of interest.

3.1.2 Other terms relating to this guide are defined in Terminology D2652.

¹ This guide is under the jurisdiction of ASTM Committee D28 on Activated Carbon and is the direct responsibility of Subcommittee D28.04 on Gas Phase Evaluation Tests.

Current edition approved Aug. 1, 2008. Published September 2008. Originally approved in 1991. Last previous edition approved in 2003 as D5160 – 95 (2003). DOI: 10.1520/D5160-95R08.

² For referenced ASTM standards, visit the ASTM website, www.astm.org, or contact ASTM Customer Service at service@astm.org. For *Annual Book of ASTM Standards* volume information, refer to the standard's Document Summary page on the ASTM website.

4. Summary of Guide

4.1 An activated carbon bed that contains a known amount of carbon is challenged with an adsorbate in a gas stream under conditions of flow rate, adsorbate concentration, temperature, pressure, and relative humidity set by the user. The time to breakthrough of a specified concentration of adsorbate is measured. The measurement is repeated using the same conditions but varying the amount of carbon in the bed. For many practical systems, a plot of breakthrough time versus amount of carbon is linear. The slope and x -intercept of this line can be used to calculate the dynamic capacity, N_o (expressed as grams adsorbate/grams carbon or grams adsorbate/cm³ carbon) and critical bed depth, d_c , characteristic of the activated carbon under the conditions used in the test.

5. Significance and Use

5.1 Activated carbon is used extensively for removing gases and vapors from air or other gas streams. The physical and chemical characteristics of an activated carbon can strongly influence its suitability for a given application. The procedure in this guide allows the evaluation of the dynamic adsorption characteristics of an activated carbon for a particular adsorbate under conditions chosen by the user. It is necessary that the user choose test conditions that are meaningful for the application (see Section 9).

5.2 This guide can also be used to evaluate activated carbons that have been impregnated with materials to enhance their effectiveness at removing gases otherwise poorly adsorbed on activated carbon.

5.3 The procedure given in this guide is not generally applicable for evaluation of carbons used as catalysts for such purposes as decomposition of low levels of ozone or oxidation of SO₂ to SO₃.

5.4 The procedure given in this guide can be applied to reactivated or regenerated activated carbons.

5.5 Fig. 1 shows the adsorbate concentration profile in an activated carbon bed at breakthrough. The bed has a zone at the inlet in which the adsorbate concentration is equal to the influent concentration. In this region the carbon is at equilibrium with adsorbate. The adsorbate concentration in the remainder of the bed drops until at the outlet it is equal to the breakthrough concentration. The shorter the length of this mass

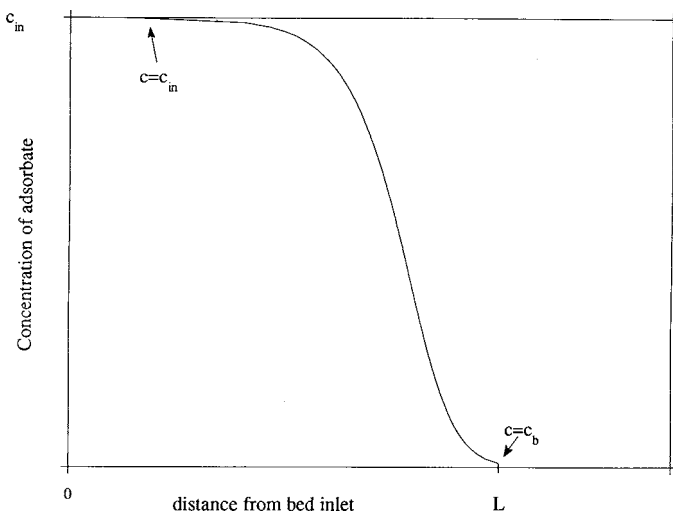

FIG. 1 Concentration Profile of an Activated Carbon Bed at Breakthrough

transfer zone (adsorption zone), the more effectively the carbon in the bed is utilized. A bed whose depth is less than the length of this zone will show immediate appearance of adsorbate in the effluent (breakpoint).

5.6 From the standpoint of best carbon utilization it is desirable to choose a carbon which will give as short a mass transfer zone as possible under use conditions. However, in many applications, high adsorptive capacity is more important than a short mass transfer zone. In almost every application, bed pressure drop is also a primary consideration.

5.7 In a few situations such as respiratory protection against low levels of extremely toxic gases such as radioactive methyl iodide, a short mass transfer zone (that is, high adsorption rate coefficient) is more important than ultimate capacity. In other cases such as solvent recovery, a high dynamic capacity is more important.

5.8 Although the design of adsorber beds is beyond the scope of this guide, the following points should be considered. The bed diameter should be as large as possible in order to lower the pressure drop and to maximize the amount of carbon in the bed. Subject to pressure drop constraints, the deepest possible carbon bed should be used. All else being equal, the use of smaller particle size carbon will shorten the mass transfer zone and improve bed efficiency at the expense of higher pressure drop. If pressure drop considerations are critical, some particle morphologies offer less resistance to flow than others.

5.9 The two parameters obtained by the procedure in this guide can be used as an aid in selecting an activated carbon and in sizing the adsorption bed in which this carbon will be used. The best carbon for most applications should have a high dynamic capacity for the adsorbate N_o coupled with a short mass transfer zone (small d_o) when evaluated under the operating conditions anticipated for the adsorber.

6. Apparatus

6.1 *Sample Tube*—This is often a vertically supported cylindrical glass tube with diameter at least twelve times the

diameter of the largest carbon particles present or 16 times the mean diameter. The lower end of the tube must have a flat support for the carbon bed. Care should be taken to ensure uniformity of flow profile across the bed. The support should contribute as little as possible to the total pressure drop of the bed. For this reason, fritted glass supports are often undesirable. Fine mesh stainless steel screens supported if necessary by heavier screens may be used. Commercially available spunbonded polyester nonwovens having both high strength and very low pressure drop may also be used as very convenient supports for tests in small tubes.

NOTE 1—A test fixture in which the bed is held in place at both top and bottom requires less skill to obtain reproducible results. An 8.8 cm diameter aluminum fixture with a perforated plate that screws down onto the bed from above has been used successfully at bed depths from 1 to 3.5 cm. A diagram of this fixture is shown in Fig. 2.

6.1.1 Flow should be downward through the sample to avoid disturbing the bed. For tests on small amounts of carbon, a ground glass outer joint at the top of the tube allows easy connection and disconnection from the challenge gas without disturbing the bed. It is very easy to disturb the packing of a small bed. Preferably these should not be moved after loading.

6.1.2 The length of the sample tube must be several times greater than the critical bed depth of the activated carbon under the test conditions chosen.

6.2 *Fill Device*—For small beds the sample tube can be loaded using the vibration feed device described in Test Method D2854. The bottom of the delivery funnel should have the same diameter as the sample tube. It is desirable to allow the carbon to fall at least 10 cm from the bottom of the delivery funnel to the top of the bed. For larger beds, the best packing is obtained when the carbon falls through a loading column which contains screens to evenly distribute the carbon across the bed.³ The column should have the same cross section as the bed.

³ British patent 606,867.

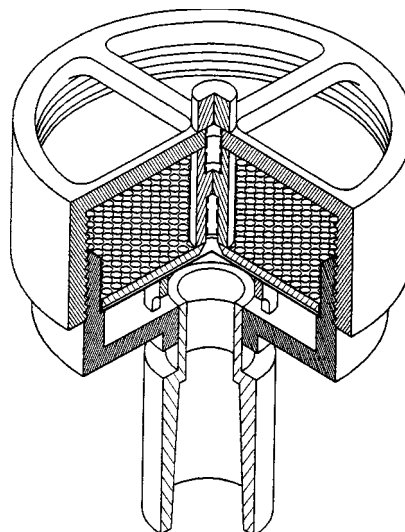

FIG. 2 Test Fixture for Gas-Phase Adsorption Testing of Activated Carbon

7. Hazards

7.1 Carbons containing toxic or radioactive adsorbates should be disposed of in accordance with applicable federal, state, and local regulations.

7.2 Certain gases and vapors have very high heats of reaction as they chemisorb on a carbon surface. At high concentrations, enough heat can be liberated to cause ignition of the carbon bed if oxygen is present. An example is chemisorption of high concentrations of phosphine or arsine on whetlerized carbon.

7.3 Another hazard is encountered when large quantities of easily oxidizable substances such as hydrazines are adsorbed on carbon from an inert gas stream. When these carbons are exposed to air, they often ignite as oxidation rapidly takes place. The same materials adsorbed in low concentrations from an air stream cause no problems since the oxidation occurs slowly during the adsorption process.

7.4 Adsorption of high concentrations of strong oxidizers such as ozone (formation of ozonides), fluorine, hydrogen peroxide, or nitric acid vapors can result in ignition or explosion of the carbon bed.

8. Selection and Preparation of Activated Carbon

8.1 A representative sample should be obtained and prepared for testing in accordance with Practice E300.

8.2 The particle size distribution of the activated carbon must be considered if several different carbons are to be compared using this procedure. All other things being equal, an activated carbon consisting of smaller particles will possess a higher adsorption rate and hence a smaller critical bed depth, d_c , than one consisting of larger particles. Therefore, carbons that have different particle sizes should not be compared against each other using critical bed depth. However, the dynamic capacities, N_o , calculated using this guide are directly comparable regardless of particle size distribution. For many applications, the dynamic capacity is more important than the critical bed depth.

8.3 Since pre-adsorbed water can strongly affect adsorption of both organic vapors and reactive gases, the water content of each carbon sample tested should be determined using Test Method D2867. Impregnated carbons are often sold containing up to about 20 % by weight water to increase their capacity for reactive gases.

8.4 The carbon tetrachloride activity (CTA) determined by Test Method D3467 is often used to qualify activated carbons for a particular use. It should be realized that these activities are a measure of the total micropore volume of an activated carbon sample. They say nothing about the distribution of micropore area among pores of various sizes. At low adsorbate concentrations, the smallest micropores are most effective. Therefore, a carbon with many small pores may have a higher capacity for a low concentration adsorbate than a carbon with greater total micropore volume (higher activity) but fewer very small pores. Fig. 3 shows a situation in which high activity is not favorable. The 57.9 % CTA carbon in this figure is specially activated to have a high proportion of very small micropores.

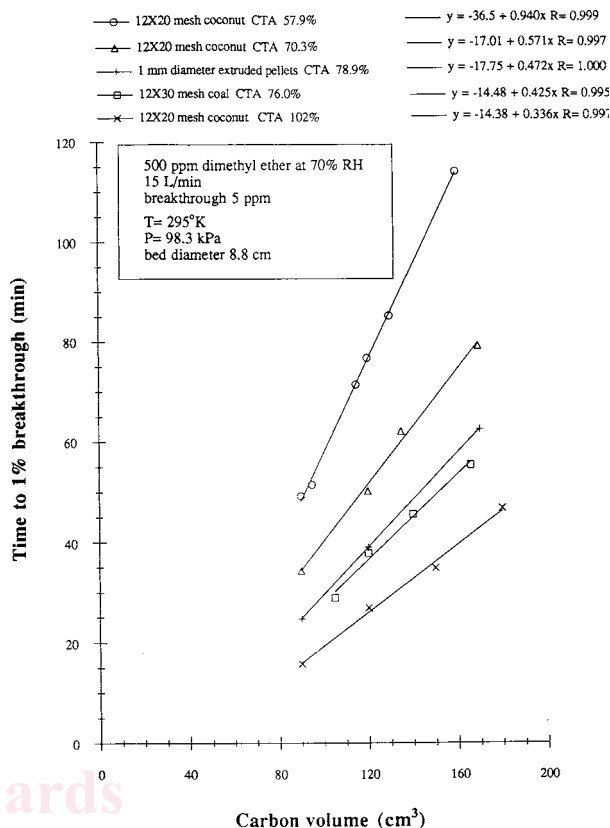

FIG. 3 Time to Breakthrough Versus Volume of Carbon

9. Selection of Test Conditions

9.1 The user of this guide must decide under what experimental conditions to evaluate the activated carbon. The preferred procedure is to use the same adsorbate concentration and same gas stream velocity as will be encountered in the application. Other factors such as relative humidity, temperature, pressure, and breakthrough concentration should also correlate as closely as possible.

9.2 Temperature affects the capacity of the activated carbon through its effects on the adsorption isotherm and on diffusion rates. This is usually not a large effect over narrow ranges of temperature for fairly non-volatile organic vapors (1).⁴ It can be much more significant for chemisorption.

9.3 The relative humidity (RH) of the challenge strongly affects the capacity and adsorption rate of the activated carbon (see Fig. 4). The RH of the challenge entering the carbon bed is the important parameter and should be carefully controlled especially at high relative humidities. As mentioned in 8.3, pre-adsorbed water also strongly influences the adsorption characteristics of the activated carbon. The strong dependence of RH on temperature at high RH values requires good temperature control at the bed when working at high RH. Generally, physical adsorption of organic vapors on dry new carbon shows little RH dependence unless the challenge RH is

⁴ The boldface numbers in parentheses refer to a list of references at the end of the text.