



Designation: C1326 – 08<sup>ε1</sup>

# Standard Test Method for Knoop Indentation Hardness of Advanced Ceramics<sup>1</sup>

This standard is issued under the fixed designation C1326; the number immediately following the designation indicates the year of original adoption or, in the case of revision, the year of last revision. A number in parentheses indicates the year of last reapproval. A superscript epsilon ( $\epsilon$ ) indicates an editorial change since the last revision or reapproval.

<sup>ε1</sup> NOTE—Added research report footnote to Section 14.6.1 editorially in September 2008.

## 1. Scope

1.1 This test method covers the determination of the Knoop indentation hardness of advanced ceramics.

1.2 The values stated in SI units are to be regarded as standard. No other units of measurement are included in this standard.

1.3 *This standard does not purport to address all of the safety concerns, if any, associated with its use. It is the responsibility of the user of this standard to establish appropriate safety and health practices and determine the applicability of regulatory limitations prior to use.*

## 2. Referenced Documents

2.1 *ASTM Standards:*<sup>2</sup>

**C730** Test Method for Knoop Indentation Hardness of Glass

**C849** Test Method for Knoop Indentation Hardness of Ceramic Whitewares

**E4** Practices for Force Verification of Testing Machines

**E177** Practice for Use of the Terms Precision and Bias in ASTM Test Methods

**E384** Test Method for Knoop and Vickers Hardness of Materials

**E691** Practice for Conducting an Interlaboratory Study to Determine the Precision of a Test Method

**IEEE/ASTM SI 10** Standard for Use of the International System of Units (SI) (The Modern Metric System)

<sup>1</sup> This test method is under the jurisdiction of ASTM Committee C28 on Advanced Ceramics and is the direct responsibility of Subcommittee C28.01 on Mechanical Properties and Performance.

Current edition approved Aug. 1, 2008. Published September 2008. Originally approved in 1996. Last previous edition approved in 2003 as C1326 – 03. DOI: 10.1520/C1326-08E01.

<sup>2</sup> For referenced ASTM standards, visit the ASTM website, [www.astm.org](http://www.astm.org), or contact ASTM Customer Service at [service@astm.org](mailto:service@astm.org). For Annual Book of ASTM Standards volume information, refer to the standard's Document Summary page on the ASTM website.

2.2 *European Standard:*

**CEN ENV 843-4** Advanced Technical Ceramics, Monolithic Ceramics, Mechanical Properties at Room Temperature, Part 4: Vickers, Knoop, and Rockwell Superficial Hardness Tests<sup>3</sup>

2.3 *ISO Standard:*

**ISO 9385** Glass and Glass Ceramics—Knoop Hardness Test<sup>4</sup>

## 3. Terminology

3.1 *Definitions:*

3.1.1 *Knoop hardness number (HK), n*—an expression of hardness obtained by dividing the force applied to the Knoop indenter by the projected area of the permanent impression made by the indenter.

3.1.2 *Knoop indenter, n*—a rhombic-based pyramidal-shaped diamond indenter with edge angles of 172° 30' and 130° 00'.

## 4. Summary of Test Method

4.1 This test method describes an indentation hardness test using a calibrated machine to force a pointed, rhombic base, pyramidal diamond indenter having specified face angles, under a predetermined load, into the surface of the material under test and measures the surface projection of the long diagonal of the resulting impression after removal of the load.

NOTE 1—A general description of the Knoop indentation hardness test is given in Test Method E384. The present test method differs from this description only in areas required by the special nature of advanced ceramics.

<sup>3</sup> Available from European Committee for Standardization (CEN), 36 rue de Stassart, B-1050, Brussels, Belgium, <http://www.cenorm.be>.

<sup>4</sup> Available from International Organization for Standardization (ISO), 1, ch. de la Voie-Creuse, Case postale 56, CH-1211, Geneva 20, Switzerland, <http://www.iso.ch>.

NOTE 2—This test method is similar to Test Methods C730 and C849, but differs primarily in the choice of load and the rate of loading. In addition, the length correction factor for the resolution limits of optical microscopes is not utilized.

## 5. Significance and Use

5.1 For advanced ceramics, Knoop indenters are used to create indentations. The surface projection of the long diagonal is measured with optical microscopes.

5.2 The Knoop indentation hardness is one of many properties that is used to characterize advanced ceramics. Attempts have been made to relate Knoop indentation hardness to other hardness scales, but no generally accepted methods are available. Such conversions are limited in scope and should be used with caution, except for special cases where a reliable basis for the conversion has been obtained by comparison tests.

5.3 For advanced ceramics, the Knoop indentation is often preferred to the Vickers indentation since the Knoop long diagonal length is 2.8 times longer than the Vickers diagonal for the same load, and cracking is much less of a problem (1).<sup>5</sup> On the other hand, the long slender tip of the Knoop indentation is more difficult to precisely discern, especially in materials with low contrast. The indentation loads chosen in this test method are designed to produce indentations as large as may be possible with conventional microhardness equipment, yet not so large as to cause cracking.

5.4 The Knoop indentation is shallower than Vickers indentations made at the same load. Knoop indents may be useful in evaluating coating hardnesses.

5.5 Knoop hardness is calculated from the ratio of the applied load divided by the projected indentation area on the specimen surface. It is assumed that the elastic springback of the narrow diagonal is negligible. (Vickers indenters are also used to measure hardness, but Vickers hardness is calculated from the ratio of applied load to the area of contact of the four faces of the undeformed indenter.)

5.6 A full hardness characterization includes measurements over a broad range of indentation loads. Knoop hardness of ceramics usually decreases with increasing indentation size or indentation force (load). The trend is known as the indentation size effect (ISE). Hardness approaches a plateau constant hardness at sufficiently large indentation size or forces (loads). The test forces or loads that are needed to achieve a constant hardness vary with the ceramic. The test force specified in this standard is intended to be sufficiently large that hardness is either close to or on the plateau, but not so large as to introduce excessive cracking. A comprehensive characterization of the ISE is recommended but is beyond the scope of this test method which measures hardness at a single, designated load.

## 6. Interferences

6.1 Cracking from the indentation tips can interfere with interpretation of the exact tip location. The loads chosen for this test method are sufficiently low that tip cracking, if it

<sup>5</sup> The boldface numbers in parentheses refer to the list of references at the end of this test method.

occurs, will cause tiny, rather tight cracks at the indentation tips in advanced ceramics. Such cracks will have a negligible interference on measurements of the long diagonal length (2) (unlike Vickers indentations in ceramics).

6.2 Cracking or spalling from the sides of the Knoop impression may also occur, possibly in a time-dependent manner (minutes or hours) after the impression is made. Small amounts of such lateral cracking have little or no influence upon measured hardness, provided that the tip impressions are still readable and the tips are not dislodged (2).

6.3 Porosity (either on or just below the surface) may interfere with measuring Knoop hardness, especially if the indentation falls directly onto a large pore or if the indentation tip falls in a pore.

6.4 At higher magnifications in the optical microscope, it may be difficult to obtain a sharp contrast between the indentation tip and the polished surface of some advanced ceramics. This may be overcome by careful adjustment of the lighting as discussed in Test Method E384 and Refs (2, 3).

## 7. Apparatus

### 7.1 Testing Machines:

7.1.1 There are two general types of machines available for making this test. One type is a self-contained unit built for this purpose, and the other type is an accessory available for existing microscopes. Usually, this second type is fitted on an inverted-stage microscope. Descriptions of the various machines are available (4–6).

7.1.2 Design of the machine should be such that the loading rate, dwell time, and applied load can be set within the limits set forth in 10.5. It is an advantage to eliminate the human element whenever possible by appropriate machine design. The machine should be designed so that vibrations induced at the beginning of a test will be damped out by the time the indenter touches the sample.

7.1.3 The calibration of the balance beam should be checked monthly or as needed. Indentations in standard reference materials may also be used to check calibration when needed.

### 7.2 Indenter:

7.2.1 The indenter shall meet the specifications for Knoop indenters. See Test Method E384.

7.2.2 Fig. 1 shows the indenter and its maximum usable dimensions. The diagonals have an approximate ratio of 7:1, and the depth of the indentation is approximately 1/30 the length of the long diagonal. A perfect Knoop indenter has the following angles:

7.2.2.1 Included longitudinal angle 172° 30 min 00 s.

7.2.2.2 Included transverse angle 130° 00 min 00 s.

7.2.3 The constant  $C_p$  (defined in 12.2) for a perfect indenter is 0.07028. The specifications require a variation of not more than 1 % from this value.

7.2.4 The offset at the indenter tip shall not exceed 1.0  $\mu\text{m}$ . See Test Method E384.

7.2.5 The four faces of the indenter shall meet at sharp edges.

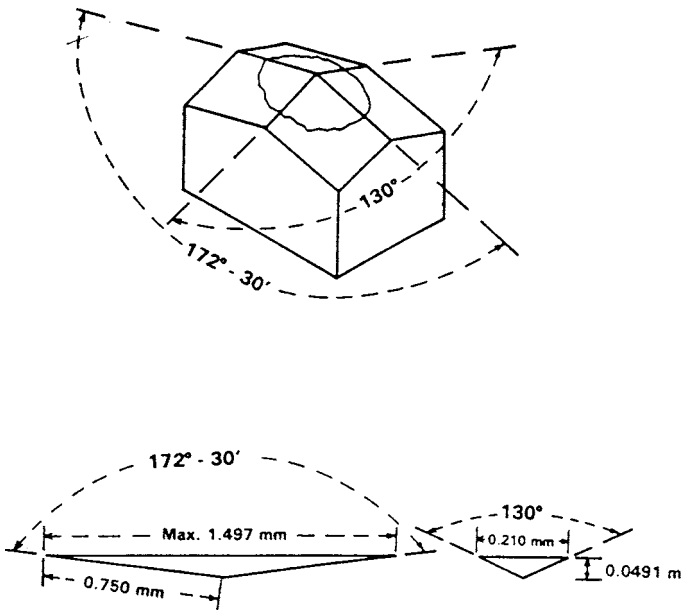

FIG. 1 Knoop Indenter Showing Maximum Usable Dimensions

7.2.6 The diamond should be examined periodically, and if it is loose in the mounting material, chipped, or cracked, it shall be replaced.

NOTE 3—This requirement is from Test Method E384 and is especially pertinent to diamond indenters that are used to measure hardness of ceramics. In addition, these indenters sometimes are used to precrack advanced ceramic specimens at loads higher than customarily used for hardness testing. Such usage can lead to indenter damage. The diamond indenter can be examined with a scanning electron microscope, or indents can be made into soft copper to help determine if a chip or crack is present. Indenters may also be inspected with an optical microscope with at least 500X power, but care should be taken to avoid damaging the microscope lens.

### 7.3 Measuring Microscope:

7.3.1 The measurement system shall be constructed so that the length of the diagonals can be determined with errors not exceeding  $\pm 0.0005$  mm.

NOTE 4—Stage micrometers with uncertainties less than this shall be used to establish calibration constants for the microscope. See Test Method E384. Ordinary stage micrometers which are used for determining the approximate magnification of photographs may be ruled too coarse or may not have the required accuracy and precision.

7.3.2 The numerical aperture (NA) of the objective lens shall be between 0.60 and 0.90.

NOTE 5—The apparent length of a Knoop indentation will increase as the resolving power and NA of a lens increases. The range of NA specified by this test method corresponds to 40 to 100 $\times$  objective lenses. The higher power lenses may have higher resolution, but the contrast between the indentation tips and the polished surface may be less.

7.3.3 A filter may be used to provide monochromatic illumination. Green filters have proved to be useful.

## 8. Test Specimens

8.1 The Knoop indentation hardness test is adaptable to a wide variety of advanced ceramic specimens. In general, the accuracy of the test will depend on the smoothness of the surface and, whenever possible, ground and polished speci-

mens should be used. The back of the specimen shall be fixed so that the specimen cannot rock or shift during the test.

8.1.1 *Thickness*—As long as the specimen is over ten times as thick as the indentation depth, the test will not be affected. In general, if specimens are at least 0.50 mm thick, the hardness will not be affected by variations in the thickness.

8.1.2 *Surface Finish*—Specimens should have a ground and polished surface. The roughness should be less than 0.1  $\mu$ m rms. However, if one is investigating a surface coating or treatment, one cannot grind and polish the specimen.

NOTE 6—This requirement is necessary to ensure that the surface is flat and that the indentation is sharp. Residual stresses from polishing are of less concern for most advanced ceramics than for glasses or metals. References (2) and (7) report that Knoop hardness was insensitive to surface finish for surfaces prepared with 1  $\mu$ m or finer diamond abrasive. Hardness was only affected when the surface finish had an optically resolvable amount of abrasive damage (7). (Extra caution may be appropriate during polishing of transformation toughening ceramics, such as some zirconias, since the effect upon hardness is not known.)

8.1.3 *Radius of Curvature*—Care should be used when relating hardness values obtained on curved surfaces to those obtained on polished, flat surfaces. The hardness values obtained will be affected even when the curvature is only in the direction of the short diagonal.

## 9. Preparation of Apparatus

9.1 *Verification of Load*—Most of the machines available for Knoop hardness testing use a loaded beam. This beam shall be tested for zero load. An indentation should not be visible with zero load, but the indenter should contact the sample. Methods of verifying the load application are given in Practices E4.

9.2 *Separate Verification of Load, Indenter, and Measuring Microscope*—Procedures in Test Method E384, Section 14, may be followed.

9.3 *Verification by Standard Reference Materials*—Standard reference blocks, SRM No. 2830, of silicon nitride that are available from the National Institute of Standards and Technology<sup>6</sup> can be used to verify that an apparatus produces a Knoop hardness within  $\pm 5\%$  of the certified value.

## 10. Procedure

10.1 *Specimen Placement*—Place the specimen on the stage of the machine so the specimen will not rock or shift during the measurement. The specimen shall be clean and free of any grease or film.

### 10.2 Specimen Leveling:

10.2.1 The surface of the specimen being tested shall lie in a plane normal to the axis of the indenter.

10.2.2 If one leg (one half) of the long diagonal is more than 10% longer than the other, or if the ends of the diagonal are not both in the field of focus, the surface of the specimen may not be normal to the axis of the indenter. Align the specimen surface properly, and make another indentation.

<sup>6</sup> Standard Reference Materials Program (NIST) 100 Bureau Drive, Stop 2300 Gaithersburg, MD 20899-2300.

NOTE 7—This tolerance is more stringent than the 20 % that is specified in Test Method E384, but is less stringent than requirements in Test Methods C730 and C849.

10.2.3 Leveling the specimen to meet these specifications is facilitated if one has a leveling device.<sup>7</sup>

10.3 *Magnitude of Test Force*—A test force of either 9.81 N (1 kgf) or 19.61 N (2 kgf) is specified. 19.61 N is preferred. 9.81 N may be used if the higher force is not available on the apparatus, if cracking is a problem, or if preferred for a specific requirement. If cracking is a problem at 9.81 N, lower forces may be used and the reporting procedure of 12.6 shall be used. (The precision might be less and the bias greater with the lower forces.) If additional forces are used (for example to measure the indentation size effect trend), then the reporting procedure of 12.6 shall be used for each data set.

NOTE 8—“Load” and “Force” are used interchangeably in this standard.

10.4 *Clean the Indenter*—The indenter shall be cleaned prior to and during a test series. A cotton swab with ethanol, methanol, or isopropanol may be used. Indenting into soft copper also may help remove debris.

NOTE 9—Ceramic powders or fragments from the ceramic test piece can adhere to the diamond indenter.

10.5 *Application of Test Load:*

10.5.1 Start the machine smoothly. The rate of indenter motion prior to contact with the specimen shall be 0.015 to 0.070 mm/s. If the machine is loaded by an electrical system or a dash-pot lever system, it should be mounted on shock absorbers which damp out all vibrations by the time the indenter touches the specimen.

NOTE 10—This rate of loading is consistent with Test Method E384, but is faster than that prescribed in Test Methods C730 and C849.

10.5.2 The time of application of the full test load shall be 15 s (±2) unless otherwise specified. After the indenter has been in contact with the specimen for this required dwell time, raise it carefully off the sample to avoid a vibration impact.

10.5.3 The operator shall not bump or inadvertently contact the test machine or the associated support (for example, the table) during the period of indenter contact with the specimen.

10.6 *Spacing of Indentations*—Allow a distance of at least one and a half indentation times the long diagonal between the indentations as illustrated in Fig. 2. If there is evidence of interaction between lateral cracking (from the sides of the indentation), then the spacing shall be increased.

10.7 *Acceptability of Indentations*— If there is excessive cracking from the indent sides, the indent shall be rejected for measurement. Fig. 3 provides guidance in this assessment. If this occurs on most indentations, a lower indentation load shall be used. If one or both tips of an indentation fall in a pore, the indentation shall be rejected. If the indentation lies in or on a

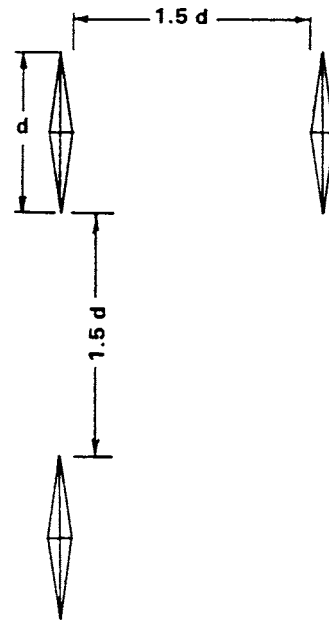

FIG. 2 Closest Permitted Spacing for Knoop Indentations

large pore, the indent shall be rejected. If the impression has an irregularity that indicates the indenter is chipped or cracked, the indent shall be rejected and the indenter shall be replaced. If the indentation is asymmetric as specified in 10.2.2 and Fig. 3, then reject the indentation.

NOTE 11—In many ceramics, porosity may be small and finely distributed. The indentations will intersect some porosity. The measured hardness in such instances properly reflects a diminished hardness relative to the fully dense advanced ceramic. The intent of the restrictions in 10.7 is to rule out obviously unsatisfactory or atypical indentations for measurement purposes.

10.8 *Location of Indentations*—Indentations shall be made in representative areas of the advanced ceramic microstructure. They shall not be restricted to high-density regions if such exist.

10.9 *Number of Indentations*—For homogeneous and fully dense advanced ceramics, at least five and preferably ten acceptable indentations shall be made. If the ceramic is multiphase, not homogeneous, or not fully dense, ten acceptable indentations shall be made.

11. Measurement of Indentation Size

11.1 The accuracy of this test method depends to a very large extent on this measurement since hardness depends upon the inverse square of the diagonal size.

11.1.1 If the measuring system contains a light source, take care to use the system only after it has reached equilibrium temperature. This is because the magnification of a microscope depends on the tube length.

11.1.2 Calibrate the measuring system carefully with a stage micrometer or an optical grating.

11.1.3 Adjust the illumination and focusing conditions carefully as specified in Test Method E384 to obtain the optimum view and clarity of the impression. Proper focus and illumination are critical for accurate and precise readings. Both

<sup>7</sup> The sole source of supply of the apparatus known to the committee at this time is the Tukon Tester leveling device, Catalog No. 85248, available from the Wilson Division of Instron Corp. If you are aware of alternative suppliers, please provide this information to ASTM Headquarters. Your comments will receive careful consideration at a meeting of the responsible technical committee,<sup>1</sup> which you may attend.