Indoor air —

Part 33:

Determination of phthalates with gas chromatography/mass spectrometry (GC/MS)

Air intérieur —

Partie 33: Détermination des phthalates par chromatographie en phase gazeuse/spectrométrie de masse (CPG/SM)

Document Preview

[ISO 16000-33:2017](https://standards.iso.org/iso/16000-33:2017)

<https://standards.iteh.ai/catalog/standards/iso/dd5e9e12-9dab-42ab-8566-b939612f7697/iso-16000-33-2017>



iTeh Standards
(<https://standards.iteh.ai>)
Document Preview

[ISO 16000-33:2017](https://standards.iteh.ai/catalog/standards/iso/dd5e9e12-9dab-42ab-8566-b939612f7697/iso-16000-33-2017)

<https://standards.iteh.ai/catalog/standards/iso/dd5e9e12-9dab-42ab-8566-b939612f7697/iso-16000-33-2017>



COPYRIGHT PROTECTED DOCUMENT

© ISO 2017, Published in Switzerland

All rights reserved. Unless otherwise specified, no part of this publication may be reproduced or utilized otherwise in any form or by any means, electronic or mechanical, including photocopying, or posting on the internet or an intranet, without prior written permission. Permission can be requested from either ISO at the address below or ISO's member body in the country of the requester.

ISO copyright office
Ch. de Blandonnet 8 • CP 401
CH-1214 Vernier, Geneva, Switzerland
Tel. +41 22 749 01 11
Fax +41 22 749 09 47
copyright@iso.org
www.iso.org

Contents

	Page
Foreword.....	v
Introduction.....	vi
1 Scope.....	1
2 Normative references.....	1
3 Terms and definitions.....	1
4 Sampling methods and analytical apparatus.....	2
4.1 General.....	2
4.2 Sampling by adsorption with subsequent thermal desorption.....	2
4.2.1 Apparatus, operating materials and chemicals.....	2
4.2.2 Preparation of the thermal desorption tube.....	3
4.2.3 Sampling.....	3
4.3 Sampling by adsorption and subsequent solvent extraction.....	4
4.3.1 Apparatus, operating materials and chemicals.....	4
4.3.2 Preparation of Florisil® ²⁾ and the adsorption tubes.....	5
4.3.3 Hints to the application of Florisil® ²⁾	6
4.3.4 Sampling.....	6
4.3.5 Sample conditioning.....	7
5 Calibration.....	7
5.1 General.....	7
5.2 Calibration of the thermal desorption method.....	8
5.3 Calibration of the solvent extraction method.....	8
6 Identification and quantification.....	8
6.1 Mass spectrometric analysis.....	8
7 Establishment of calibration curves and calculation of the analyte mass.....	14
7.1 Establishment of calibration curves.....	14
7.2 Calculation of the analyte mass.....	14
8 Calculation of indoor air concentrations.....	15
9 Performance characteristics.....	16
9.1 Detection limit.....	16
9.2 Quantification limit and problems related to the blank values.....	16
9.3 Reproducibility standard deviation and repeatability standard deviation.....	17
10 Quality assurance.....	19
10.1 Method verification and determination of blanks.....	19
10.1.1 Field blank value of the indoor air.....	19
10.1.2 Analytical laboratory blank value.....	19
10.2 Measures for blank value minimization.....	19
10.3 Documents.....	20
11 Interferences.....	20
Annex A (informative) General information on phthalates.....	21
Annex B (informative) Screening phthalates in solvent wipe tests.....	24
Annex C (informative) Screening phthalates in house dust.....	27
Annex D (informative) Practical example for the calibration of the thermal desorption method.....	31
Annex E (informative) Practical example for the calibration of the solvent extraction method using Florisil®²⁾.....	33
Annex F (informative) Practical example for the gas chromatography with thermal desorption.....	35

Annex G (informative) Practical example for the gas chromatography following solvent extraction	36
Annex H (informative) Problems related to the blank values	37
Annex I (informative) Example of a sampling protocol	38
Bibliography	39

iTeh Standards
(<https://standards.itih.ai>)
Document Preview

[ISO 16000-33:2017](https://standards.itih.ai/catalog/standards/iso/dd5e9e12-9dab-42ab-8566-b939612f7697/iso-16000-33-2017)

<https://standards.itih.ai/catalog/standards/iso/dd5e9e12-9dab-42ab-8566-b939612f7697/iso-16000-33-2017>

Foreword

ISO (the International Organization for Standardization) is a worldwide federation of national standards bodies (ISO member bodies). The work of preparing International Standards is normally carried out through ISO technical committees. Each member body interested in a subject for which a technical committee has been established has the right to be represented on that committee. International organizations, governmental and non-governmental, in liaison with ISO, also take part in the work. ISO collaborates closely with the International Electrotechnical Commission (IEC) on all matters of electrotechnical standardization.

The procedures used to develop this document and those intended for its further maintenance are described in the ISO/IEC Directives, Part 1. In particular the different approval criteria needed for the different types of ISO documents should be noted. This document was drafted in accordance with the editorial rules of the ISO/IEC Directives, Part 2 (see www.iso.org/directives).

Attention is drawn to the possibility that some of the elements of this document may be the subject of patent rights. ISO shall not be held responsible for identifying any or all such patent rights. Details of any patent rights identified during the development of the document will be in the Introduction and/or on the ISO list of patent declarations received (see www.iso.org/patents).

Any trade name used in this document is information given for the convenience of users and does not constitute an endorsement.

For an explanation on the voluntary nature of standards, the meaning of ISO specific terms and expressions related to conformity assessment, as well as information about ISO's adherence to the World Trade Organization (WTO) principles in the Technical Barriers to Trade (TBT) see the following URL: www.iso.org/iso/foreword.html.

This document was prepared by Technical Committee ISO/TC 146, *Air quality*, Subcommittee SC 6, *Indoor air*.

A list of all parts in the ISO 16000 series can be found on the ISO website.

[ISO 16000-33:2017](http://www.iso.org/iso/16000-33:2017)

<https://standards.iteh.ai/catalog/standards/iso/dd5e9e12-9dab-42ab-8566-b939612f7697/iso-16000-33-2017>

Introduction

The different parts of ISO 16000 describe general requirements relating to the measurement of indoor air pollutants and the important conditions to be observed before or during the sampling of individual pollutants or groups of pollutants, as well as the measurement procedures themselves (see Foreword).

The definition of indoor environment is given by ISO 16000-1. Dwellings [living rooms, bedrooms, do-it-yourself (DIY) rooms, sports rooms and cellars, kitchens and bathrooms], workrooms or workplaces in buildings which are not subject to health and safety inspections with respect to air pollutants (e.g. offices, salesrooms), public buildings (e.g. restaurants, theatres, cinemas and other meeting rooms) and passenger cabins of motor vehicles and public transport are among the most important types of indoor environment.

Phthalates, the diesters of the ortho-phthalic acid (1,2-benzene dicarbon acid), are emitted into the indoor air primarily from articles of daily use made of soft polyvinyl chloride (PVC). Typically, phthalates are used as plasticizers in soft PVC. The five most frequently used phthalates are diisodecylphthalate (DiDP), diisononylphthalate (DiNP), di(2-ethylhexyl)-phthalate (DEHP), di-*n*-butyl-phthalate (DBP), and benzyl-*n*-butyl-phthalate (BBP). An overview of the most important phthalates, their acronyms and several relevant substance properties can be found in [Table A.1](#). These phthalates can be determined in indoor environments by means of the analytical methods incorporating gas chromatography/mass spectrometry specified in this document.

iTeh Standards (<https://standards.iteh.ai>) Document Preview

[ISO 16000-33:2017](#)

<https://standards.iteh.ai/catalog/standards/iso/dd5e9e12-9dab-42ab-8566-b939612f7697/iso-16000-33-2017>

Indoor air —

Part 33:

Determination of phthalates with gas chromatography/ mass spectrometry (GC/MS)

1 Scope

This document specifies the sampling and analysis of phthalates in indoor air and describes the sampling and analysis of phthalates in house dust and in solvent wipe samples of surfaces by means of gas chromatography/mass spectrometry.

Two alternative sampling and processing methods, whose comparability has been proven in a round robin test, are specified for indoor air^[4]. Sampling can take place using sorbent tubes with subsequent thermal desorption and GC-MS analysis. Alternatively, sampling can take on other types of sorbent tubes that are subsequently analysed by solvent extraction with GC-MS.

Depending on the sampling method, the compounds dimethyl phthalate to diisoundecylphthalate can be analysed in house dust as described in [Annex C](#)^[8]. The investigation of house dust samples is only appropriate as a screening method. This investigation only results in indicative values and is not acceptable for a final assessment of a potential need for action.

Dimethyl phthalate to diisoundecylphthalate can be analysed in solvent wipe samples as described in [Annex B](#). Solvent wipe samples are suitable for non-quantitative source identification.

NOTE In principle, the method is also suitable for the analysis of other phthalates, adipates and cyclohexane dicarboxylic acid esters, but this is confirmed by determination of the performance characteristics in each case.

<https://standards.iteh.ai/DocumentPreview/ISO-16000-33:2017/42ab-8566-b939612f7697/iso-16000-33-2017>
<https://www.iso.org/obp/GeneralInformationOnPhthalates> are given in [Annex A](#).

2 Normative references

The following documents are referred to in the text in such a way that some or all of their content constitutes requirements of this document. For dated references, only the edition cited applies. For undated references, the latest edition of the referenced document (including any amendments) applies.

ISO 16000-6:2011, *Indoor air — Part 6: Determination of volatile organic compounds in indoor and test chamber air by active sampling on Tenax TA sorbent, thermal desorption and gas chromatography using MS or MS-FID*

3 Terms and definitions

No terms and definitions are listed in this document.

ISO and IEC maintain terminological databases for use in standardization at the following addresses:

- ISO Online browsing platform: available at <https://www.iso.org/obp>
- IEC Electropedia: available at <http://www.electropedia.org/>

4 Sampling methods and analytical apparatus

4.1 General

Sampling of indoor air takes place either by adsorption on a thermal desorption tube filled with quartz wool and Tenax® TA¹⁾ or on adsorbents such as Florisil®²⁾ with subsequent solvent extraction^{[4][5]}. The quantity of solvent used for solvent extraction procedures should be minimized in order to minimize blank values. All apparatus and reagents used should be clean, i.e. without detectable quantities of the compounds of interest.

The experiences from the round robin test have indicated that significant blank value differences can also be introduced by the solvent. Each new bottle of solvent shall therefore be tested for phthalate contamination before use^[4].

NOTE The experiences from the round robin test have indicated that rinsing with clean solvent (no detectable phthalates) is sufficient to remove contamination from the apparatus and that a sterilization by heating with subsequent deactivation of the heated glass apparatus is not mandatory.

The ubiquitous distribution of phthalates shall be considered during sampling of indoor air in order to avoid contamination of the sample. The measures to be considered for blank value minimization, as well as the advantages and disadvantages of the individual methods, are described in detail in the respective clauses. Further hints to quality assurance and problems related to blank values that shall be considered are listed in [Clause 10](#).

4.2 Sampling by adsorption with subsequent thermal desorption

Use the apparatus, reagents and materials described in ISO 16000-6 (including the informative annex on semi-volatile compounds) with the following additional specific requirements:

4.2.1 Apparatus, operating materials and chemicals

4.2.1.1 Thermal desorption tube, stainless steel, inert-coated steel or glass tube filled with a 1 cm loosely packed plug of non-friable quartz wool backed up by at least 200 mg of adsorbent, e.g. Tenax® TA¹⁾ 20/35 (see ISO 16000-6:2011, Annex D).

4.2.1.2 Sampling system, according to [Figure 1](#).

4.2.1.3 Pump, suitable for a volume flow in the range 50 ml/min to 200 ml/min under the sampling conditions; recommended sampling volume of approximately 20 l to approximately 70 l.

4.2.1.4 Gas volume meter, the maximal measurement inaccuracy shall not exceed 5 %.

4.2.1.5 Laboratory sampling facilities, hygrometer, thermometer, barometer.

4.2.1.6 Internal standards, required as quality control measure of the whole analytical process including sampling; suitable examples include: the ring-deuterated compounds D4-DMP, D4-DEP, D4-DBP, D4-BBP, D4-DEHP, D4-DOP as well as the non-deuterated diallyl phthalate (DAIP), see [Clause 5](#) and [Table 3](#). Standards shall be prepared in phthalate-free methanol, as described in ISO 16000-6, at a level such that a maximum 1 µl injection introduces approximately the same mass of analyte onto the sampling end of the tubes as is expected to be collected during sampling.

1) Tenax® TA is the trade name of a product supplied by Buchem. This information is given for the convenience of the users of this document and does not constitute an endorsement by ISO of the product named. Equivalent products may be used if they can be shown to lead to the same results.

2) Florisil® is the trade name of product supplied by U.S. Silica. This information is given for the convenience of the users of this document and does not constitute an endorsement by ISO of the product named. Equivalent products may be used if they can be shown to lead to the same results.

4.2.1.7 Thermal desorption unit, coupled to GC-MS for the two-stage thermal desorption of the sorbent tubes and transfer of desorbed vapours via an inert gas flow into a gas chromatographic (GC) system, fitted with a mass spectrometric (MS) detector.

NOTE Deactivated (silanised) glass wool or quartz wool can also be used as adsorbent after an appropriate method validation.

4.2.2 Preparation of the thermal desorption tube

The use of a tube packed with quartz wool and Tenax® TA¹) presupposes knowledge of ISO 16000-6. Prepacked and preconditioned sorbent tubes are available commercially or can be prepared in the laboratory as follows:

A plug of non-friable quartz wool, usually supported by a stainless steel mesh, is inserted at the sampling end of the tube. The required mass of sorbent is poured into the tube behind the quartz wool plug. The far end of the sorbent bed is typically supported by a second plug of quartz wool or a stainless steel mesh.

A minimum of 200 mg sorbent shall be used per tube in order to guarantee the sorption capacity.

NOTE Determination of the breakthrough volume is described in ISO 16017-1:2000, Annex B. The breakthrough volumes are proportional to the dimensions and masses of the sorbents. The rule of the thumb is that the guaranteed sample volume doubles itself when the sorbent bed length is doubled (while retaining the tube diameter).

After filling of the thermal desorption tubes (e.g. with Tenax® TA¹), the tubes are conditioned for approximately 8 h at 280 °C followed by approximately 30 min at 300 °C in an inert gas flow (100 ml/min). The purified sorption tubes are closed and stored at room temperature and in the dark in a container that prevents sample contamination.

Analyse a representative number of conditioned tubes for blank value, using routine analytical parameters, to ensure that thermal desorption blank is sufficiently small (see ISO 16000-6:2011, 7.1).

Sampling should take place as soon as possible after conditioning. If sampling is not possible within approximately 14 days after conditioning, then the tube shall be reconditioned for 15 min at approximately 300 °C before sampling. In order to avoid contamination, the thermal desorption tubes should be touched only with cotton gloves. In addition, labelling shall be omitted.

The thermal desorption device should ensure that any contamination from external tube surfaces is excluded from the analytical sample flow path. If the selected analytical system does not do this, tubes shall only be handled using clean cotton gloves, in the field and laboratory, to minimize contamination.

Tubes should be indelibly and individually labelled but without attaching adhesive labels which might jam or discolour during thermal desorption.

4.2.3 Sampling

Prior to sampling, the conditioned tubes are spiked with a maximum of 1 µl internal standard solution in methanol (e.g. 20 ng/µl for a sampling volume of 50 l; the absolute mass of the additionally spiked standard depends on the sampling volume and the operating range of the method). The standard solution is usually applied on the sampling end of the sorbent tube.

The sampling equipment is assembled according to [Figure 1](#) and shall be free of leaks. The pump is connected to the non-sampling end of the sorbent tube by means of polyethylene or polytetrafluoroethylene (PTFE) connectors and is switched on. If the breakthrough volume of the analysed phthalates is unknown, then two sorption tubes shall be connected in series. The tubes shall be connected with a phthalate-free coupling.

The volume flow, as well as the temperature, the absolute air pressure and the relative air humidity, shall be recorded. The suitable sampling volume flows are within the range of 50 ml/min to 200 ml/min. This corresponds to a recommended sampling volume of approximately 20 l to 70 l for a sampling

duration of approximately 2 h to 24 h. After sampling, the sorption tube is removed from the sampling equipment; both ends of the sorption tube shall be closed.

A duplicate sampling of the indoor air is recommended.

Sampled tubes shall be transported to the laboratory and analysed as soon as possible.

4.3 Sampling by adsorption and subsequent solvent extraction

4.3.1 Apparatus, operating materials and chemicals

4.3.1.1 **Sampling system**, according to [Figure 1](#).

4.3.1.2 **Pump**, suitable for a volume flow of approximately 2 l/min under the conditions of the sampling, recommended sampling volume of approximately 1 m³ to 3 m³ in 8 h to 24 h.

4.3.1.3 **Gas volume meter**, the maximal measurement inaccuracy shall not exceed 5 %.

4.3.1.4 **Muffle furnace**.

4.3.1.5 **Flat, heat resistant evaporating dish**, for heating Florisil®²).

4.3.1.6 **Florisil®²**, 60 to 100 mesh.

4.3.1.7 **Glass wool**, silanized.

4.3.1.8 **Glass flask**, with screw-cap and polytetrafluoroethylene (PTFE) sealing, 50 ml.

4.3.1.9 **Adsorption tubes**, glass tube, approximately 200 mm long, internal diameter approximately 10 mm to 12 mm.

<https://standards.iteh.ai/catalog/standards/iso/dd5e9e12-9dab-42ab-8566-b939612f7697/iso-16000-33-2017>

4.3.1.10 **Laboratory sampling facilities**, hygrometer, thermometer, barometer.

4.3.1.11 **Solvent**, e.g. tertiary butyl methyl ether (TBME) or toluene, free of blank values (solvent shall be tested for the absence of phthalate blank values).

4.3.1.12 **Internal standards**, suitable are, e.g. the ring-deuterated compounds D4-DMP, D4-DEP, D4-DBP, D4-BBP, D4-DEHP, D4-DOP as well as the non-deuterated diallyl phthalate (DAIP); see [Clause 5](#) and [Table 3](#).

4.3.1.13 GC-MS, gas chromatographic (GC) system, fitted with a mass spectrometric (MS) detector.

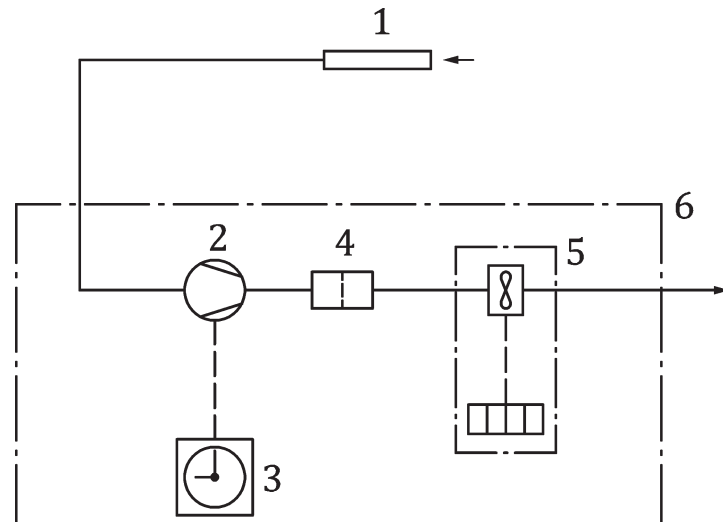

Key

- 1 sampling tube
- 2 membrane vacuum pump
- 3 timer switch (optional)
- 4 anti-abrasion filter
- 5 volume measuring device or mass flow controller
- 6 protective housing

Figure 1 — Schematic diagram of the sampling equipment

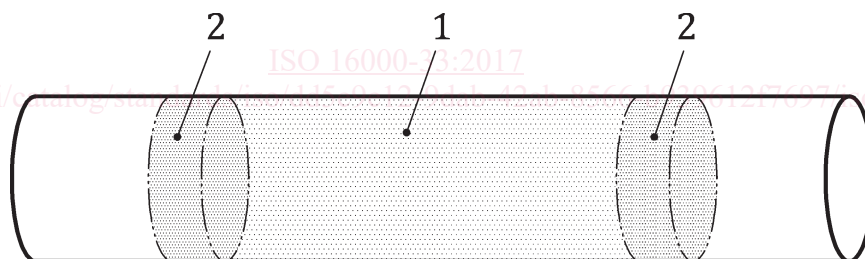

Figure 2 — Filling of the glass tube

Key

- 1 Florisil®²⁾
- 2 glass wool

4.3.2 Preparation of Florisil®²⁾ and the adsorption tubes

Florisil®²⁾ is spread out in a thin layer (approximately 3 cm to 4 cm) on an evaporation dish and heated at 800 °C for 6 h. After cooling down in the desiccator it is deactivated with bi-distilled water (3 % proportion by mass). To this end, 5 g Florisil®²⁾ and 150 µl water are given to a 50 ml glass flask with a screw-cap and polytetrafluoroethylene (PTFE) sealing. After closing the flask, Florisil®²⁾ shall be mixed for approximately 45 min until a uniformly flowing powder has formed again. The deactivated Florisil®²⁾ is then filled into an adsorption tube (see [Figure 2](#)). The filling height should be

approximately 10 cm to 13 cm. The ends of the Florisil®²⁾ filling are closed with silanised glass wool. The filled tubes are stored in the desiccator over silica gel until air sampling.

NOTE The geometry of the tube is based on the DFG³⁾ method^[15].

4.3.3 Hints to the application of Florisil®²⁾

Each charge of Florisil®²⁾ newly heated and deactivated according to 4.3.2 shall be examined for blank values. Charges where high phthalate blank values are still measured after such treatment shall be heated and deactivated anew.

As long as the prepared tubes are stored in the desiccator, they are suitable for storage and use within up to six months. After expiration of this period, unused tubes shall be emptied and the Florisil®²⁾ shall be treated again according to 4.3.2.

Other adsorbents such as Chromosorb 106 or comparable carrier materials can be utilized as adsorption agents. Adsorbent preparation and sampling shall then be modified accordingly, and the suitability shall be proven by a determination of the performance characteristics.

4.3.4 Sampling

A defined volume (e.g. 10 µl) of the internal standard solution (e.g. 100 mg/l, this corresponds to an absolute mass of the internal standard of 1 µg) shall be added prior to sampling. The preparation of the solutions of the internal standards is described in Annex D (for thermal desorption method) and in Annex E (for solvent extraction method using Florisil®²⁾).

The internal standard is added (typically) by means of a microlitre syringe. The standard solution is usually placed on the adsorbent on the side oriented towards the flow. The amount to be added for the anticipated operating ranges from 0,05 µg/m³ to 10 µg/m³ is listed in Table 1. The compounds listed in Clause 5 are suitable as internal standards.

Table 1 — Operating range for determination of phthalates with contents from 0,05 µg/m³ to 10 µg/m³ in an air sample

Concentration of the reduced sampling solution mg/l	Corresponds to a concentration in the air µg/m ³
0,05	0,05
0,1	0,1
0,5	0,5
1,0	1,0
2,5	2,5
5,0	5,0
10,0	10,0

The data concerning the calculated concentrations in the air are tentative. The actual detection and quantification limits of the method shall be determined by the test laboratory based on the calibration under consideration of the blank value.

NOTE The data given in Table 1 are valid for an air volume of 1 m³ and a sample processing as described in 4.3.5.

The sampling equipment is assembled according to Figure 1 and a leak test is performed. The volume flow, as well as the temperature, the absolute air pressure and the relative air humidity, shall be recorded. Sampling takes place by means of a pump, and the sampling volume amounts to 1 m³ to

3) DFG stands for Deutsche Forschungsgemeinschaft, i.e. the German Research Foundation.