

iTeh STANDARD PREVIEW
(standards.iteh.ai)

SIST EN 16842-4:2019

<https://standards.iteh.ai/catalog/standards/sist/fa2fed82-5e73-45e2-b451-bd3141b43be8/sist-en-16842-4-2019>

EUROPEAN STANDARD

EN 16842-4

NORME EUROPÉENNE

EUROPÄISCHE NORM

March 2019

ICS 53.060

English Version

Powered industrial trucks- Visibility - Test methods and verification - Part 4 : Industrial variable reach trucks up to and including 10 000 kg capacity

Chariots de manutention automoteurs - Visibilité -
Méthodes d'essai et vérification - Partie 4 : Chariots de
manutention à portée variable ayant une capacité
allant jusqu'à 10 000 kg inclus

Kraftbetriebene Flurförderzeuge - Sichtverhältnisse -
Prüfverfahren und Verifikation - Teil 4:
Flurförderzeuge mit veränderlicher Reichweite bis zu
und einschließlich einer Nenntragfähigkeit von
10 000 kg

This European Standard was approved by CEN on 22 May 2018.

CEN members are bound to comply with the CEN/CENELEC Internal Regulations which stipulate the conditions for giving this European Standard the status of a national standard without any alteration. Up-to-date lists and bibliographical references concerning such national standards may be obtained on application to the CEN-CENELEC Management Centre or to any CEN member.

(standards.iteh.ai)

This European Standard exists in three official versions (English, French, German). A version in any other language made by translation under the responsibility of a CEN member into its own language and notified to the CEN-CENELEC Management Centre has the same status as the official versions.

<https://standards.iteh.ai/catalog/standards/sist/fa2fed82-5e73-45e2-b451-sist/en-16842-4:2019>

CEN members are the national standards bodies of Austria, Belgium, Bulgaria, Croatia, Cyprus, Czech Republic, Denmark, Estonia, Finland, Former Yugoslav Republic of Macedonia, France, Germany, Greece, Hungary, Iceland, Ireland, Italy, Latvia, Lithuania, Luxembourg, Malta, Netherlands, Norway, Poland, Portugal, Romania, Serbia, Slovakia, Slovenia, Spain, Sweden, Switzerland, Turkey and United Kingdom.



EUROPEAN COMMITTEE FOR STANDARDIZATION
COMITÉ EUROPÉEN DE NORMALISATION
EUROPÄISCHES KOMITEE FÜR NORMUNG

CEN-CENELEC Management Centre: Rue de la Science 23, B-1040 Brussels

Contents	Page
European foreword.....	3
Introduction	5
1 Scope.....	6
2 Normative references.....	6
3 Terms and definitions	6
4 Truck configuration	6
4.1 General.....	6
4.2 Fork arm dimensions.....	6
5 Test equipment.....	7
6 Test procedures for direct visibility.....	7
6.1 Lighting equipment position.....	7
6.1.1 General.....	7
6.1.2 Sit-on operator	7
6.2 Test paths.....	8
6.3 Measurement procedure.....	9
6.4 Test procedure for indirect visibility.....	9
7 Acceptance criteria.....	9
7.1 General.....	9
7.2 Direct visibility.....	9
7.2.1 General.....	9
7.2.2 Travelling visibility	9
7.2.3 Manoeuvring visibility	9
7.2.4 Fork arms.....	9
7.3 Indirect visibility.....	9
7.4 Criteria for industrial variable-reach trucks $\leq 10\ 000$ kg rated capacity.....	10
8 Test report.....	11
9 Information for use	11
Bibliography.....	12

European foreword

This document (EN 16842-4:2019) has been prepared by Technical Committee CEN/TC 150 "Industrial trucks - Safety", the secretariat of which is held by BSI.

This European Standard shall be given the status of a national standard, either by publication of an identical text or by endorsement, at the latest by September 2019, and conflicting national standards shall be withdrawn at the latest by September 2019.

Attention is drawn to the possibility that some of the elements of this document may be the subject of patent rights. CEN shall not be held responsible for identifying any or all such patent rights.

This European Standard is intended to be used in combination with the requirements in EN 16842-1.

EN 16842 consists of the following parts under the general title *Powered industrial trucks – Visibility – Test methods and verification*:

- *Part 1: General requirements;*
- *Part 2: Sit-on counterbalance trucks and rough terrain masted trucks up to and including 10 000 kg capacity;*
- *Part 3: Reach trucks up to and including 10 000 kg capacity;*
- *Part 4: Industrial variable-reach trucks up to and including 10 000 kg capacity;*
- *Part 5: Industrial variable-reach trucks greater than 10 000 kg capacity*
- *Part 6: Sit-on counterbalance trucks and rough terrain masted trucks greater than 10 000 kg capacity;*
- *Part 7: Variable-reach and masted container trucks handling freight containers of 6 m (20 ft) length and longer;*
- *Part 8: Stand on counterbalance trucks up to and including 10 000 kg capacity (in preparation);*
- *Part 9: Order-picking, lateral- and front-stacking trucks with elevating operator position*
- *Part 10: Towing and pushing tractors and burden carrier;*

It is intended to develop additional parts related to the following machinery:

- Pallet stacking trucks (rider controlled);
- Single side loader;
- Multi-directional forklift truck;
- Articulated counterbalance lift truck;
- Non-stacking low lift straddle carriers (as defined in ISO 5053-1:2015, 3.18);
- Stacking high lift straddle carriers (as defined in ISO 5053-1:2015, 3.19).

EN 16842-4:2019 (E)

According to the CEN-CENELEC Internal Regulations, the national standards organisations of the following countries are bound to implement this European Standard: Austria, Belgium, Bulgaria, Croatia, Cyprus, Czech Republic, Denmark, Estonia, Finland, Former Yugoslav Republic of Macedonia, France, Germany, Greece, Hungary, Iceland, Ireland, Italy, Latvia, Lithuania, Luxembourg, Malta, Netherlands, Norway, Poland, Portugal, Romania, Serbia, Slovakia, Slovenia, Spain, Sweden, Switzerland, Turkey and the United Kingdom.

**iTeh STANDARD PREVIEW
(standards.iteh.ai)**

SIST EN 16842-4:2019

<https://standards.iteh.ai/catalog/standards/sist/fa2fed82-5e73-45e2-b451-bd3141b43be8/sist-en-16842-4-2019>

Introduction

This document is a type-C standard as stated in EN ISO 12100.

This document is of relevance, in particular, for the following stakeholder groups representing the market players with regard to machinery safety:

- machine manufacturers (small, medium and large enterprises);
- health and safety bodies (regulators, accident prevention organizations, market surveillance, etc.).

Others can be affected by the level of machinery safety achieved with the means of the document by the above-mentioned stakeholder groups:

- machine users/employers (small, medium and large enterprises);
- machine users/employees (e.g. trade unions, organizations for people with special needs);
- service providers, e.g. for maintenance (small, medium and large enterprises);
- consumers (in case of machinery intended for use by consumers).

The above-mentioned stakeholder groups have been given the possibility to participate at the drafting process of this document.

The machinery concerned and the extent to which hazards, hazardous situations or hazardous events are covered are indicated in the Scope of this document.

When requirements of this type-C standard are different from those which are stated in type-A or type-B standards, the requirements of this type-C standard take precedence over the requirements of the other standards for machines that have been designed and built according to the requirements of this type-C standard.

EN 16842-4:2019 (E)**1 Scope**

This document specifies the requirements and test procedures for 360° visibility of sit-on self-propelled industrial variable-reach trucks (herein after referred to as trucks) without a load, with a capacity up to and including 10 000 kg in accordance with ISO 5053-1 and it is intended be used in conjunction with EN 16842-1.

Where specific requirements in this part are modified from the general requirements in EN 16842-1, the requirements of this part are truck specific and to be used for sit-on self-propelled industrial variable-reach trucks with a capacity up to and including 10 000 kg.

This part of EN 16842 deals with all significant hazards, hazardous situations or hazardous events, relevant to the visibility of the operator for applicable machines when used as intended and under conditions of misuse which are reasonably foreseeable by the manufacturer.

This document does not apply to rough-terrain variable-reach trucks (see EN 15830).

2 Normative references

The following documents are referred to in the text in such a way that some or all of their content constitutes requirements of this document. For dated references, only the edition cited applies. For undated references, the latest edition of the referenced document (including any amendments) applies.

EN 16842-1:2018, *Powered industrial trucks — Visibility — Test methods and verification — Part 1: General requirements*

EN ISO 3691-2:2016, *Industrial trucks — Safety requirements and verification — Part 2: Self-propelled variable-reach trucks (ISO 3691-2:2016)*

ISO 5053-1, *Industrial trucks — Terminology and classification — Part 1: Types of industrial trucks*

3 Terms and definitions

For the purposes of this document, the terms and definitions given in EN 16842-1, ISO 5053-1 and EN ISO 3691-2 apply.

ISO and IEC maintain terminological databases for use in standardization at the following addresses:

- IEC Electropedia: available at <http://www.electropedia.org/>
- ISO Online browsing platform: available at <http://www.iso.org/obp>

4 Truck configuration**4.1 General**

For truck test configuration, EN 16842-1:2018, Clause 4 shall apply.

4.2 Fork arm dimensions

The test truck shall be equipped with fork arms of the following nominal lengths:

- Truck < 1 000 kg rated capacity: 800 mm,
- Truck \geq 1 000 kg and < 5 000 kg rated capacity: 1 000 mm, and
- Truck \geq 5 000 kg and \leq 10 000 kg rated capacity: 1 200 mm.

Other fork arm lengths shall be tested if these adversely affect visibility (e.g. shorter fork arms, etc.).

Lengths of forks arms shall be noted in the test report in accordance with EN 16842-1:2018, 8.2 i).

NOTE Fork arm lengths in millimetres are given as two times the length of the standard load centre distance as defined in EN ISO 3691-2:2016, A.3.1.

5 Test equipment

For test equipment EN 16842-1:2018, Clause 5 shall apply.

6 Test procedures for direct visibility

6.1 Lighting equipment position

6.1.1 General

The visibility from the truck shall be determined from the operating position with light sources and a test body or screen. The lighting equipment simulates the range of eye positions of the operator. The test body simulates an obstacle to be seen.

6.1.2 Sit-on operator

The lighting equipment shall be positioned relative to the seat index point (SIP). The seat shall be placed at the closest adjustment position to the mid-point of horizontal and vertical adjustment and the mid-point of the suspension height, if so equipped (see Figure 1).

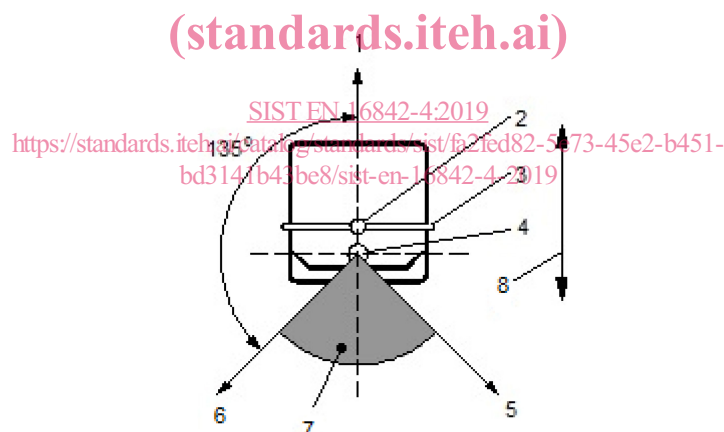

Sit-on truck where the operator is facing the line of travel

Key

1	0° seat direction	5	+135° test direction
2	SIP	6	-135° test direction
3	row of lights	7	the row of lights cannot be turned to this area for tests
4	row of lights axis of rotation	8	forward and rearward truck direction for all seat positions shown

Figure 1 — Seat position and test direction