

ETSI ES 202 706-1 V1.7.1 (2022-08)



**Environmental Engineering (EE);
Metrics and measurement method for energy efficiency
of wireless access network equipment;
Part 1: Power consumption - static measurement method**

[ETSI ES 202 706-1 V1.7.1 \(2022-08\)](https://standards.iteh.ai/catalog/standards/sist/7af0b787-a3ae-4c5e-aac2-0d341f444364/etsi-es-202-706-1-v1-7-1-2022-08)

<https://standards.iteh.ai/catalog/standards/sist/7af0b787-a3ae-4c5e-aac2-0d341f444364/etsi-es-202-706-1-v1-7-1-2022-08>

Reference

RES/EE-EEPS52

Keywordsenergy efficiency, GSM, LTE, NR,
power measurement, WCDMA**ETSI**650 Route des Lucioles
F-06921 Sophia Antipolis Cedex - FRANCE

Tel.: +33 4 92 94 42 00 Fax: +33 4 93 65 47 16

Siret N° 348 623 562 00017 - APE 7112B
Association à but non lucratif enregistrée à la
Sous-Préfecture de Grasse (06) N° w061004871

Important noticeThe present document can be downloaded from:
<http://www.etsi.org/standards-search>

The present document may be made available in electronic versions and/or in print. The content of any electronic and/or print versions of the present document shall not be modified without the prior written authorization of ETSI. In case of any existing or perceived difference in contents between such versions and/or in print, the prevailing version of an ETSI deliverable is the one made publicly available in PDF format at www.etsi.org/deliver.

Users of the present document should be aware that the document may be subject to revision or change of status. Information on the current status of this and other ETSI documents is available at <https://portal.etsi.org/TB/ETSIDeliverableStatus.aspx>

If you find errors in the present document, please send your comment to one of the following services:
<https://standards-portal.etsi.org/People/CommitteeSupportStaff.aspx>

If you find a security vulnerability in the present document, please report it through our Coordinated Vulnerability Disclosure Program:
<https://www.etsi.org/standards/coordinated-vulnerability-disclosure>

Notice of disclaimer & limitation of liability

The information provided in the present deliverable is directed solely to professionals who have the appropriate degree of experience to understand and interpret its content in accordance with generally accepted engineering or other professional standard and applicable regulations.

No recommendation as to products and services or vendors is made or should be implied.

No representation or warranty is made that this deliverable is technically accurate or sufficient or conforms to any law and/or governmental rule and/or regulation and further, no representation or warranty is made of merchantability or fitness for any particular purpose or against infringement of intellectual property rights.

In no event shall ETSI be held liable for loss of profits or any other incidental or consequential damages.

Any software contained in this deliverable is provided "AS IS" with no warranties, express or implied, including but not limited to, the warranties of merchantability, fitness for a particular purpose and non-infringement of intellectual property rights and ETSI shall not be held liable in any event for any damages whatsoever (including, without limitation, damages for loss of profits, business interruption, loss of information, or any other pecuniary loss) arising out of or related to the use of or inability to use the software.

Copyright Notification

No part may be reproduced or utilized in any form or by any means, electronic or mechanical, including photocopying and microfilm except as authorized by written permission of ETSI.

The content of the PDF version shall not be modified without the written authorization of ETSI.
The copyright and the foregoing restriction extend to reproduction in all media.

© ETSI 2022.
All rights reserved.

Contents

Intellectual Property Rights	5
Foreword.....	5
Modal verbs terminology.....	5
Introduction	5
1 Scope	7
2 References	7
2.1 Normative references	7
2.2 Informative references.....	8
3 Definition of terms, symbols and abbreviations.....	9
3.1 Terms.....	9
3.2 Symbols.....	10
3.3 Abbreviations	10
4 Assessment method	12
5 Reference configurations and Measurement conditions.....	12
5.0 Introduction	12
5.1 Reference configurations.....	12
5.2 Measurement and test equipment requirements	14
5.2.0 Introduction.....	14
5.2.1 BS Configuration.....	15
5.2.2 RF output (transmit) power/signal	15
5.2.3 Environmental conditions.....	15
5.2.4 Power supply	16
6 Static Power Measurement.....	16
6.0 Introduction	16
6.1 Measurement methods.....	16
6.1.0 Introduction.....	16
6.1.1 Test setup for conducted power measurement.....	17
6.1.2 Test setup for radiated power measurement.....	18
6.1.3 Power measurement procedure	19
6.1.4 Power measurement in RF sharing mode	19
6.1.5 Power measurement of multi-band configurations	20
6.1.5.0 Introduction.....	20
6.1.5.1 Configuration of a multi-band BS	20
6.1.5.2 Specific configurations for dual band GSM.....	20
6.1.5.3 Specific configurations for dual band LTE (LTE-A).....	20
6.1.5.4 Specific configurations for dual band and dual technology	21
6.2 Uncertainty	21
7 Calculation results	21
7.1 Load distribution profile.....	21
7.2 Integrated base station	21
7.2.0 Introduction.....	21
7.2.1 Calculation of average power consumption of integrated BS.....	22
7.2.2 Calculation of daily energy consumption of integrated BS	22
7.3 Distributed base station	22
7.3.0 Introduction.....	22
7.3.1 Calculation of average power consumption of distributed BS.....	22
7.3.2 Calculation of daily energy consumption of distributed BS	23
8 Measurement report.....	23
Annex A (normative): Test Reports	24
A.1 General information to be reported	24

A.2	Static measurement report	25
Annex B (normative):	Reference parameters for GSM/EDGE system.....	27
Annex C (normative):	Reference parameters for WCDMA/HSDPA system	29
Annex D (normative):	Reference parameters for LTE system	30
Annex E (normative):	Reference parameters for NR system	34
Annex F (normative):	Reference parameters for multi-standard system.....	36
Annex G (normative):	Uncertainty assessment	38
G.0	Introduction	38
G.1	General requirements	38
G.2	Components contributing to uncertainty	39
G.2.0	Introduction	39
G.2.1	Contribution of the measurement system	39
G.2.1.1	Measurement equipment.....	39
G.2.1.2	Attenuators, cables.....	39
G.2.2	Contribution of physical parameters.....	39
G.2.2.1	Impact of environmental parameters.....	39
G.2.3	Variance of device under test	39
G.3	Uncertainty assessment	40
G.3.1	Combined and expanded uncertainties	40
G.3.2	Cross correlation of uncertainty factors.....	40
G.3.3	Maximum expanded uncertainty	40
Annex H (informative):	Example assessment.....	41
Annex I (informative):	Interpolation method.....	43
Annex J (informative):	Load placement examples	44
Annex K (informative):	Bibliography.....	47
History	48

Intellectual Property Rights

Essential patents

IPRs essential or potentially essential to normative deliverables may have been declared to ETSI. The declarations pertaining to these essential IPRs, if any, are publicly available for **ETSI members and non-members**, and can be found in ETSI SR 000 314: "*Intellectual Property Rights (IPRs); Essential, or potentially Essential, IPRs notified to ETSI in respect of ETSI standards*", which is available from the ETSI Secretariat. Latest updates are available on the ETSI Web server (<https://ipr.etsi.org/>).

Pursuant to the ETSI Directives including the ETSI IPR Policy, no investigation regarding the essentiality of IPRs, including IPR searches, has been carried out by ETSI. No guarantee can be given as to the existence of other IPRs not referenced in ETSI SR 000 314 (or the updates on the ETSI Web server) which are, or may be, or may become, essential to the present document.

Trademarks

The present document may include trademarks and/or tradenames which are asserted and/or registered by their owners. ETSI claims no ownership of these except for any which are indicated as being the property of ETSI, and conveys no right to use or reproduce any trademark and/or tradename. Mention of those trademarks in the present document does not constitute an endorsement by ETSI of products, services or organizations associated with those trademarks.

DECT™, **PLUGTESTS™**, **UMTS™** and the ETSI logo are trademarks of ETSI registered for the benefit of its Members. **3GPP™** and **LTE™** are trademarks of ETSI registered for the benefit of its Members and of the 3GPP Organizational Partners. **oneM2M™** logo is a trademark of ETSI registered for the benefit of its Members and of the oneM2M Partners. **GSM®** and the GSM logo are trademarks registered and owned by the GSM Association.

Foreword

This ETSI Standard (ES) has been produced by ETSI Technical Committee Environmental Engineering (EE).

The present document is part 1 of a multi-part deliverable covering the metrics and measurement method for energy efficiency of wireless access network equipment, as identified below:

ETSI ES 202 706-1: "Power consumption - static measurement method";

ETSI TS 102 706-2: "Energy Efficiency - dynamic measurement method".

Modal verbs terminology

In the present document "**shall**", "**shall not**", "**should**", "**should not**", "**may**", "**need not**", "**will**", "**will not**", "**can**" and "**cannot**" are to be interpreted as described in clause 3.2 of the [ETSI Drafting Rules](#) (Verbal forms for the expression of provisions).

"**must**" and "**must not**" are **NOT** allowed in ETSI deliverables except when used in direct citation.

Introduction

Energy efficiency is one of the critical factors of the modern telecommunication systems. The energy consumption of the access network is the dominating part of the wireless telecom network energy consumption. Therefore the core network and the service network are not considered in the present document. In the radio access network, the energy consumption of the Base Station is dominating (depending on technology often also referred to as BTS, NodeB, eNodeB, gNodeB, etc. and in the present document denoted as BS).

The present document, ETSI ES 202 706-1, defines the measurement method for the evaluation of base station power consumption and energy consumption with static load:

- Average power consumption of BS equipment under static test conditions: the BS average power consumption is based on measured BS power consumption data under static condition when the BS is loaded artificially in a lab for three different loads, low, medium and busy hour under given reference configuration.
- Daily average energy consumption.

ETSI TS 102 706-2 [i.8] defines energy efficiency measurement of the LTE base station with dynamic load, and ETSI TS 103 786 [i.10] defines energy efficiency measurement of the NR base station with dynamic load.

i T E h S T A N D A R D P R E
(s t a n d a r d s . i t

E T S I E S 2 0 2 . 7 0 6 - 1
h t t p s : / / s t a n d a r d s . i t e h . :
0 d 3 4 1 f 4 4 4 3 6 4 / e t s i - e

1 Scope

The present document version covers base stations with the following radio access technologies:

- GSM.
- WCDMA.
- LTE.
- NR.

The methodology described in the present document is to measure base station static power consumption and RF output power. Within the present document it is referred to as static measurements.

The results based on "static" measurements provide power and energy consumption figures for BS under static load.

Energy consumption of terminal (end-user) equipment is outside the scope of the present document.

The scope of the present document is not to define target values for the BS power and energy consumption.

The results should only be used to assess and compare the power and energy consumption of complete base stations.

Wide Area Base Stations and Medium Range Base Stations (as defined in ETSI TS 125 104 [2], ETSI TS 136 104 [12], and ETSI TS 138 104 [15]) are covered in the present document.

2 References

2.1 Normative references

References are either specific (identified by date of publication and/or edition number or version number) or non-specific. For specific references, only the cited version applies. For non-specific references, the latest version of the referenced document (including any amendments) applies.

Referenced documents which are not found to be publicly available in the expected location might be found at <https://docbox.etsi.org/Reference/>.

NOTE: While any hyperlinks included in this clause were valid at the time of publication, ETSI cannot guarantee their long term validity.

The following referenced documents are necessary for the application of the present document.

- | | |
|-----|------------------------------------------------------------------------------------------------------------------------------------------------------------------------------------------|
| [1] | Void. |
| [2] | ETSI TS 125 104: "Universal Mobile Telecommunications System (UMTS); Base Station (BS) radio transmission and reception (FDD) (3GPP TS 25.104)". |
| [3] | ETSI EN 300 132-1: "Environmental Engineering (EE); Power supply interface at the input to Information and Communication Technology (ICT) equipment; Part 1: Alternating Current (AC)". |
| [4] | ETSI EN 300 132-2: "Environmental Engineering (EE); Power supply interface at the input of Information and Communication Technology (ICT) equipment; Part 2: -48 V Direct Current (DC)". |
| [5] | Void. |
| [6] | Void. |
| [7] | ETSI TS 125 141: "Universal Mobile Telecommunications System (UMTS); Base Station (BS) conformance testing (FDD) (3GPP TS 25.141)". |
| [8] | Void. |

- [9] Void.
- [10] ETSI TS 136 211: "LTE; Evolved Universal Terrestrial Radio Access (E-UTRA); Physical channels and modulation (3GPP TS 36.211)".
- [11] ETSI TS 136 141: "LTE; Evolved Universal Terrestrial Radio Access (E-UTRA); Base Station (BS) conformance testing (3GPP TS 36.141)".
- [12] ETSI TS 136 104: "LTE; Evolved Universal Terrestrial Radio Access (E-UTRA); Base Station (BS) radio transmission and reception (3GPP TS 36.104)".
- [13] Void.
- [14] ETSI EN 300 132-3: "Environmental Engineering (EE); Power supply interface at the input of Information and Communication Technology (ICT) equipment; Part 3: Up to 400 V Direct Current (DC)".
- [15] ETSI TS 138 104: "5G; NR; Base Station (BS) radio transmission and reception (3GPP TS 38.104)".
- [16] ETSI TS 138 141-1: "5G; NR; Base Station (BS) conformance testing Part 1: Conducted conformance testing (3GPP TS 38.141-1)".
- [17] ETSI TS 138 141-2: "5G; NR; Base Station (BS) conformance testing Part 2: Radiated conformance testing (3GPP TS 38.141-2)".
- [18] ETSI TS 138 211: "5G; NR; Physical channels and modulation (3GPP TS 38.211)".

2.2 Informative references

References are either specific (identified by date of publication and/or edition number or version number) or non-specific. For specific references, only the cited version applies. For non-specific references, the latest version of the referenced document (including any amendments) applies.

NOTE: While any hyperlinks included in this clause were valid at the time of publication, ETSI cannot guarantee their long term validity.

The following referenced documents are not necessary for the application of the present document but they assist the user with regard to a particular subject area.

- [i.1] Void.
- [i.2] IEC/ISO Guide 98-3:2008: "Evaluation of measurement data - Guide to the expression of uncertainty in measurement" 2008 or equivalent GUM:2008/JCGM 100:2008.
- [i.3] ETSI TS 145 005: "Digital cellular telecommunications system (Phase 2+) (GSM); GSM/EDGE Radio transmission and reception (3GPP TS 45.005)".
- [i.4] ISO/IEC 17025: "General requirements for the competence of testing and calibration laboratories".
- [i.5] ETSI TS 151 021: "Digital cellular telecommunications system (Phase 2+) (GSM); Base Station System (BSS) equipment specification; Radio aspects (3GPP TS 51.021)".
- [i.6] IEC 62018: "Power consumption of information technology equipment - Measurement methods".

NOTE: Equivalent to EN 62018 (produced by CENELEC).

- [i.7] Void.
- [i.8] ETSI TS 102 706-2: "Environmental Engineering (EE); Metrics and Measurement Method for Energy Efficiency of Wireless Access Network Equipment; Part 2: Energy Efficiency - dynamic measurement method".
- [i.9] ETSI TR 103 117: "Environmental Engineering (EE); Principles for Mobile Network level energy efficiency".

- [i.10] ETSI TS 103 786: "Environmental Engineering (EE); Measurement method for energy efficiency of wireless access network equipment; Dynamic energy performance measurement method of 5G Base Station (BS)".

3 Definition of terms, symbols and abbreviations

3.1 Terms

For the purposes of the present document, the following terms apply:

Base Station (BS): radio access network component which serves one or more radio cells and interfaces the user terminal (through air interface) and a wireless network infrastructure

BS test control unit: unit which can be used to control and manage BS locally in a lab

BS type 1-C: NR BS operating at FR1, with a conducted interface (antenna connectors available)

BS type 1-H: NR BS operating at FR1, with both a conducted (TAB connectors) and a radiated interface

BS type 1-O: NR BS operating at FR1, with only a radiated interface (no antenna connectors available)

BS type 2-O: NR BS operating at FR2, with only a radiated interface (no antenna connectors available)

busy hour: period during which occurs the maximum total load in a given 24-hour period

busy hour load: the highest measurement level of radio resource configuration

distributed BS: BS architecture which contains remote radio heads (i.e. RRH) close to antenna element and a central element connecting BS to network infrastructure

efficiency: relation between the useful output (telecom service, etc.) and energy consumption

energy consumption: integral of power consumption over time

full load: operating mode including all radio resources and 100 % traffic conditions

integrated BS: BS architecture in which all BS elements are located close to each other; for example in one single cabinet

NOTE: The integrated BS architecture may include Tower Mount Amplifier (TMA) close to antenna.

low load: lowest measurement level of radio resource configuration

medium load: medium measurement level of radio resource configuration

medium range BS: Base Station that is characterized by a rated output power (PRAT) above 24 dBm and less than or equal to 38 dBm

NOTE 1: According to ETSI TS 136 104 [12], ETSI TS 125 104 [2] and ETSI TS 138 104 [15].

NOTE 2: For BS type 1-O and BS type 2-O specific definitions apply according to ETSI TS 138 104 [15].

multi-band base station: configuration which allows the simultaneous operation on at least two different frequency bands

power saving feature: software/hardware feature in a BS which contributes to decrease power consumption

radiated interface boundary: reference where the radiated requirements apply for BS type 1-O and 2-O

NOTE: For requirements based on EIRP, the *radiated interface boundary* is associated to the far-field region.

rated output power: mean power level per carrier that the manufacturer has declared to be available at the antenna connector

NOTE: For FDD BS, rated output power is the mean power level per carrier that the manufacturer has declared to be available at the antenna connector. For TDD BS rated output power is the mean power level per carrier over an active timeslot that the manufacturer has declared to be available at the antenna connector.

site correction factor: scaling factor to scale the BS equipment power consumption for reference site configuration taking into account different power supply solutions, different cooling solutions and power supply losses

static measurement: power consumption measurement performed with different radio resource configurations with pre-defined and fixed load levels

transceiver array boundary: conducted interface between the transceiver unit array and the composite antenna for BS type 1-H

wide area BS: Base Station that is characterized by a Rated output Power (PRAT) greater than 38 dBm

NOTE 1: According to ETSI TS 136 104 [12], ETSI TS 125 104 [2], and ETSI TS 138 104 [15].

NOTE 2: For BS type 1-O and BS type 2-O specific definitions apply according to ETSI TS 138 104 [15].

3.2 Symbols

Void.

3.3 Abbreviations

For the purposes of the present document, the following abbreviations apply:

AAS	Active Antenna System
AAU	Active Antenna Unit
AC	Alternating Current
BCCH	Broadcast Control CHannel
BH	Busy Hour
BS	Base Station
BSC	Base Station Controller
BTS	Base Transceiver Station
CA	Carrier Aggregation
CATR	Compact Antenna Test Range
CCE	Control Channel Element
CCH	Common CHannel
CCPCH	Common Control Physical CHannel
CP	Cyclic Prefix
CPICH	Common Pilot CHannel
CS	Circuit Switched
DC	Direct Current
DL	DownLink
DPCH	Dedicated Physical CHannel
DUT	Device Under Test
EDGE	Enhanced Data rate GSM Evolution
EIRP	Equivalent Isotropically Radiated Power
EPRE	Emitted Power per Resource Element
FDD	Frequency Division Duplex
FL	Full Load
FR1	Frequency Range 1 (450 - 6 000 MHz), defined for NR
FR2	Frequency Range 2 (24 250 - 52 600 MHz), defined for NR
GERAN	GSM/EDGE Radio Access Network
GP	Guard Period
GSM	Global System for Mobile communication
GUM	Guide to the expression of Uncertainty in Measurement

HSPA	High Speed Packet Access
HW	HardWare
JCGM	Joint Committee for Guides in Metrology
LTE	Long Term Evolution
LTE-A	Long Term Evolution Advanced
MCPA	Multi Carrier Power Amplifier
MIMO	Multiple Input Multiple Output
MNO	Mobile Network Operator
MU-MIMO	Multi-User MIMO
NA	Not Applicable
NIST	National Institute of Standards and Technology
NR	New Radio
OFDM	Orthogonal Frequency Division Multiplex
OTA	Over The Air
PBCH	Physical Broadcast Control CHannel
PC	Power for Central Part
P_{cell}	Primary cell
PCFICH	Physical Control Format Indicator CHannel
PCH	Paging CHannel
PCM	Pulse Code Modulation
PDCCH	Physical Downlink Control CHannel
PDF	Probability Density Function
PDSCH	Physical Downlink Shared CHannel
PHICH	Physical Hybrid ARQ Indicator CHannel
PICH	Paging Indicator CHannel
PRAT	Rated output Power
PRB	Physical Resource Block
PRRH	Power for Remote Radio Head
PSS	Primary Synchronization Signal
RE	Resource Element
REG	Resource Element Group
RF	Radio Frequency
RIB	Radiated Interface Boundary
RMSI	Remaining Minimum System Information
RNC	Radio Network Controller
RRH	Remote Radio Head
RS	Reference Signals
RX	Receiver
SA	Subframe Assignment
S_{cell}	Secondary cell
SCH	Synchronization Channel
SCS	Sub-Carrier Spacing
SDH	Synchronous Digital Hierarchy
SF	Spreading Factor
SIB1	System Information Block 1
SIMO	Single Input Multiple Output
SS	Synchronization Signal
SSB	Synchronization Signal Block
SSS	Secondary Synchronization Signal
SW	SoftWare
TAB	Transceiver Array Boundary
TDD	Time Division Duplex
TMA	Tower Mount Amplifier
TRX	Transceiver
TS	Time Slot
TTI	Transmission Time Interval
TX	Transmitter
UE	User Equipment
UL	UpLink
UTRA	Universal Terrestrial Radio Access
WCDMA	Wideband Code Division Multiple Access

4 Assessment method

The assessment method is covering the BS equipment average power and energy consumption for which the present document defines reference BS equipment configurations and reference load levels to be used when measuring BS RF output power, power consumption and calculating daily average energy consumption.

The assessment procedure contains the following tasks:

- 1) Identification of equipment under test (clause A.1):
 - 1.1) Identify BS basic parameters.
 - 1.2) List BS configuration and traffic load(s) for measurements (annexes B, C, D and E).
 - 1.3) List used power saving features.
- 2) Measure BS RF output power and corresponding equipment power consumption for required load levels (clauses 5 and 6).
- 3) Calculate average power consumption and daily energy consumption (clause 7).
- 4) Collect and report the measurement and calculation results (clause A.2).

5 Reference configurations and Measurement conditions

5.0 Introduction (standards.iteh.ai)

The BS equipment is a network component which serves one or more cells and interfaces the mobile station (through air interface) and a wireless network infrastructure (such as BSC or RNC, [i.3] and [2]).

5.1 Reference configurations

Reference configurations are defined for the different technologies (GSM/EDGE, WCDMA/HSPA, LTE, NR) in the corresponding annexes (annexes B to E).

These configurations include integrated BS (Figure 1) and distributed BS (Figure 2), mast head amplifiers, remote radio heads, RF feeder cables, number of carriers, number of sectors, power range per sector, frequency range, diversity, MIMO.

With Active Antenna Systems (AAS), used in NR, more BS types are defined ETSI TS 138 104 [15]:

- BS type 1-C: NR BS operating at FR1, with a conducted interface (antenna connectors available). This corresponds to legacy integrated BS and distributed BS, illustrated in Figures 1 and 2, respectively.
- BS type 1-H: Distributed NR BS operating at FR1, with both a conducted (at TAB connectors) and a radiated interface at the RIB.
- BS type 1-O and 2-O: Distributed NR BS operating at FR1 or FR2, respectively, with only a radiated interface at the RIB.

The BS shall be tested with its intended commercially available configuration at temperatures defined in clause 5.2.3 "Environmental conditions". It shall be clearly reported in the measurement report if the BS cannot be operated without additional air-conditioning at the defined temperatures.

Appropriate transmission e.g. a transport function for E1/T1/Gbit Ethernet or other providing capacity corresponding to the BS capacity, shall be included in the BS configuration during testing. The configurations include:

- 1) UL diversity (This is a standard feature in all BS. Therefore it is considered sufficient that the test is performed on the main RX antenna only. The diversity RX shall be active during the measurement without connection to the test signal).
- 2) DL diversity (Not considered in WCDMA and HSPA. LTE: Transmission mode 3 "Open loop spatial multiplexing" shall be according to ETSI TS 136 211 [10] (2×2 DL MIMO). NR: Rank 1, single layer transmission, (MU-MIMO)).

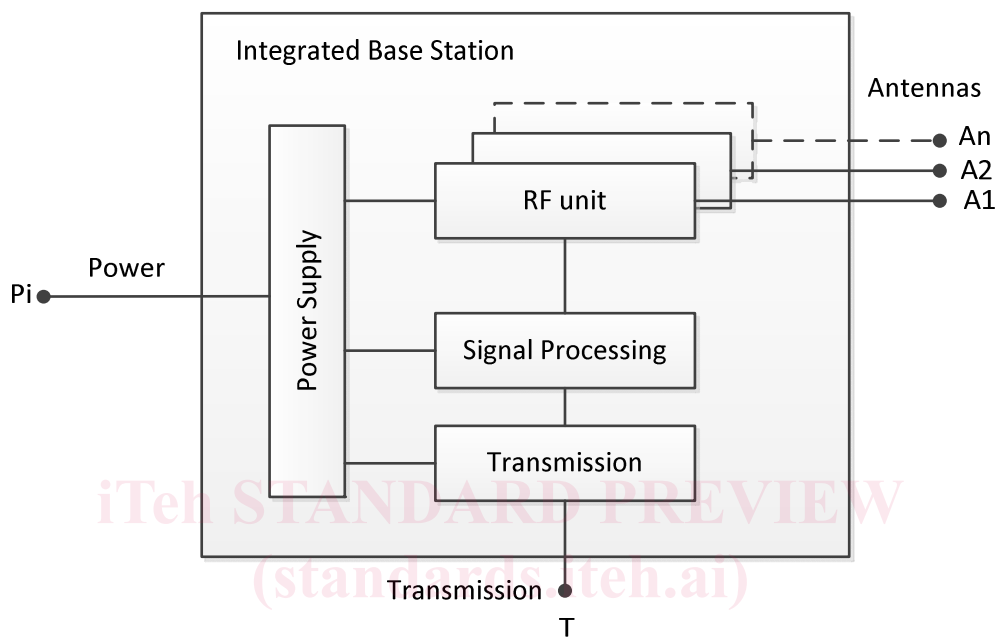

Figure 1: Integrated BS model (example)