



SLOVENSKI STANDARD

SIST EN 301 002-4 V1.1.3:2005

01-julij-2005

8 [[]HJbc`ca fYy`Y`n`]bH[f]fUb]a]glcf]hj Ua]fG8 BŁ!`Dcghcd_]j Ufcj UbY[UcfcX`U
fG9 HŁ!`Dfclc_c`X][]HJbY`bUfc b]y_Y`g][bU]nUW]Y`yh`r`%f8 GG%Ł!`("XY.`5 VglfU`fb]
dfYg_i yUb]b]n`f5 HGL]b`XcXUrbU]bZ`fa UW]UnUdfYg_i yUb`Y`XY`bY]nj YXVY
dfclc_c`UfD`L`#Ł!`DfcZ`fa UgdYW]Z`UW]UnUi dcfUvb]_U

Integrated Services Digital Network (ISDN); Security tools (SET) procedures; Digital Subscriber Signalling System No. one (DSS1) protocol; Part 4: Abstract Test Suite (ATS) and partial Protocol Implementation eXtra Information for Testing (PIXIT) proforma specification for the user

[SIST EN 301 002-4 V1.1.3:2005](https://standards.iteh.ai/catalog/standards/sist/2cb79201-b1e0-42f4-924b-92cb004aa592/sist-en-301-002-4-v1-1-3-2005)

<https://standards.iteh.ai/catalog/standards/sist/2cb79201-b1e0-42f4-924b-92cb004aa592/sist-en-301-002-4-v1-1-3-2005>

Ta slovenski standard je istoveten z: EN 301 002-4 Version 1.1.3

ICS:

33.080	Digitalno omrežje z integriranimi storitvami (ISDN)	Integrated Services Digital Network (ISDN)
--------	---	--

SIST EN 301 002-4 V1.1.3:2005 en

iTeh STANDARD PREVIEW
(standards.iteh.ai)

SIST EN 301 002-4 V1.1.3:2005

<https://standards.iteh.ai/catalog/standards/sist/2cb79201-b1e0-42f4-924b-92cb004aa592/sist-en-301-002-4-v1-1-3-2005>

ETSI EN 301 002-4 V1.1.3 (2000-05)

European Standard (Telecommunications series)

**Integrated Services Digital Network (ISDN);
Security tools (SET) procedures;
Digital Subscriber Signalling System No. one (DSS1) protocol;
Part 4: Abstract Test Suite (ATS) and partial Protocol
Implementation eXtra Information for Testing (PIXIT)
proforma specification for the user**

**iTeh STANDARD PREVIEW
(standards.iteh.ai)**

[SIST EN 301 002-4 V1.1.3:2005](https://standards.iteh.ai/catalog/standards/sist/2cb79201-b1e0-42f4-924b-92cb004aa592/sist-en-301-002-4-v1-1-3-2005)

<https://standards.iteh.ai/catalog/standards/sist/2cb79201-b1e0-42f4-924b-92cb004aa592/sist-en-301-002-4-v1-1-3-2005>



Reference

DEN/SPS-05141-4

KeywordsATS, DSS1, ISDN, PIXIT, security,
supplementary service, user**ETSI**650 Route des Lucioles
F-06921 Sophia Antipolis Cedex - FRANCE

Tel.: +33 4 92 94 42 00 Fax: +33 4 93 65 47 16

Siret N° 348 623 562 00017 - NAF 742 C
Association à but non lucratif enregistrée à la
Sous-Préfecture de Grasse (06) N° 7803/88

iTeh STANDARD PREVIEW
(standards.iteh.ai)

SIST EN 301 002-4 V1.1.3:2005<https://standards.iteh.ai/catalog/standards/sist/2cb79201-b1e0-42f4-924b-92cb004aa592/sist-en-301-002-4-v1-1-3-2005>

Important notice

Individual copies of the present document can be downloaded from:

<http://www.etsi.org>

The present document may be made available in more than one electronic version or in print. In any case of existing or perceived difference in contents between such versions, the reference version is the Portable Document Format (PDF).

In case of dispute, the reference shall be the printing on ETSI printers of the PDF version kept on a specific network drive within ETSI Secretariat.

Users of the present document should be aware that the document may be subject to revision or change of status.

Information on the current status of this and other ETSI documents is available at <http://www.etsi.org/tb/status/>

If you find errors in the present document, send your comment to:
editor@etsi.fr

Copyright Notification

No part may be reproduced except as authorized by written permission.
The copyright and the foregoing restriction extend to reproduction in all media.

© European Telecommunications Standards Institute 2000.
All rights reserved.

Contents

Intellectual Property Rights.....	5
Foreword	5
1 Scope.....	6
2 References.....	6
3 Definitions and abbreviations	7
3.1 Definitions	7
3.2 Abbreviations	7
4 Abstract Test Method.....	7
5 Untestable test purposes.....	8
6 ATS conventions.....	8
6.1 Version of TTCN used	8
6.2 Use of ASN.1	8
6.2.1 Situations where ASN.1 is used.....	8
6.2.2 Specification of encoding rules.....	8
7 ATS to TP map.....	9
8 PCTR conformance.....	9
9 PIXIT conformance.....	10
10 ATS conformance	10
Annex A (normative): Protocol Conformance Test Report (PCTR) proforma.....	11
A.1 Identification summary	11
A.1.1 Protocol conformance test report.....	11
A.1.2 IUT identification.....	11
A.1.3 Testing environment.....	11
A.1.4 Limits and reservations.....	12
A.1.5 Comments.....	12
A.2 IUT conformance status	12
A.3 Static conformance summary	12
A.4 Dynamic conformance summary.....	12
A.5 Static conformance review report	13
A.6 Test campaign report.....	13
A.7 Observations.....	14
Annex B (normative): Partial PIXIT proforma.....	15
B.1 Identification summary	15
B.2 Abstract test suite summary	15
B.3 Test laboratory	15
B.4 Client (of the test laboratory).....	16
B.5 System Under Test (SUT).....	16
B.6 Protocol information	17
B.6.1 Protocol identification.....	17
B.6.2 IUT information	17

iTech STANDARD PREVIEW
(standards.itech.ai)

[SIST EN 301 002-4 V1.1.3:2005](https://standards.itech.ai/catalog/standards/sist/2cb79201-b1e0-4244-924b-92cb004aa592/sist-en-301-002-4-v1-1-3-2005)

<https://standards.itech.ai/catalog/standards/sist/2cb79201-b1e0-4244-924b-92cb004aa592/sist-en-301-002-4-v1-1-3-2005>

B.6.2.1	Parameter values	17
B.6.2.2	Configuration of IUT	17
B.6.2.3	Timer values	17
B.7	Basic call PIXIT items	18
B.7.1	Parameter values - information element codings	18
Annex C (normative):	Abstract Test Suite (ATS).....	19
C.1	The TTCN Graphical form (TTCN.GR).....	19
C.2	The TTCN Machine Processable form (TTCN.MP)	19
	Bibliography	20
	History	21

iTeh STANDARD PREVIEW (standards.iteh.ai)

[SIST EN 301 002-4 V1.1.3:2005](https://standards.iteh.ai/catalog/standards/sist/2cb79201-b1e0-42f4-924b-92cb004aa592/sist-en-301-002-4-v1-1-3-2005)

<https://standards.iteh.ai/catalog/standards/sist/2cb79201-b1e0-42f4-924b-92cb004aa592/sist-en-301-002-4-v1-1-3-2005>

Intellectual Property Rights

IPRs essential or potentially essential to the present document may have been declared to ETSI. The information pertaining to these essential IPRs, if any, is publicly available for **ETSI members and non-members**, and can be found in SR 000 314: "*Intellectual Property Rights (IPRs); Essential, or potentially Essential, IPRs notified to ETSI in respect of ETSI standards*", which is available from the ETSI Secretariat. Latest updates are available on the ETSI Web server (<http://www.etsi.org/ipr>).

Pursuant to the ETSI IPR Policy, no investigation, including IPR searches, has been carried out by ETSI. No guarantee can be given as to the existence of other IPRs not referenced in SR 000 314 (or the updates on the ETSI Web server) which are, or may be, or may become, essential to the present document.

Foreword

This European Standard (Telecommunications series) has been produced by ETSI Technical Committee Services and Protocols for Advanced Networks (SPAN).

The present document is part 4 of a multi-part EN covering the Integrated Services Digital Network (ISDN); Security tools (SET) procedures; Digital Subscriber Signalling System No. one (DSS1) protocol, as identified below:

- Part 1: "Protocol specification";
- Part 2: "Protocol Implementation Conformance Statement (PICS) proforma specification";
- Part 3: "Test Suite Structure and Test Purposes (TSS&TP) specification for the user";
- Part 4: "Abstract Test Suite (ATS) and partial Protocol Implementation eXtra Information for Testing (PIXIT) proforma specification for the user";**
- Part 5: "Test Suite Structure and Test Purposes (TSS&TP) specification for the network";
- Part 6: "Abstract Test Suite (ATS) and partial Protocol Implementation eXtra Information for Testing (PIXIT) proforma specification for the network".

National transposition dates

Date of adoption of this EN:	28 April 2000
Date of latest announcement of this EN (doa):	31 July 2000
Date of latest publication of new National Standard or endorsement of this EN (dop/e):	31 January 2001
Date of withdrawal of any conflicting National Standard (dow):	31 January 2001

1 Scope

The present document specifies the Abstract Test Suite (ATS) and partial Protocol Implementation eXtra Information for Testing (PIXIT) proforma for the User side of the T reference point or coincident S and T reference point of implementations conforming to the stage three standard for the Security Tools (SET) supplementary service for the pan-European Integrated Services Digital Network (ISDN) by means of the Digital Subscriber Signalling System No. one (DSS1) protocol, EN 301 002-1 [1].

EN 301 002-3 [3] specifies the Test Suite Structure and Test Purposes (TSS&TP) related to this ATS and partial PIXIT proforma specification. Other parts specify the TSS&TP and the ATS and partial PIXIT proforma for the User side of the T reference point or coincident S and T reference point of implementations conforming to EN 301 002-1 [1].

2 References

The following documents contain provisions which, through reference in this text, constitute provisions of the present document.

- References are either specific (identified by date of publication, edition number, version number, etc.) or non-specific.
- For a specific reference, subsequent revisions do not apply.
- For a non-specific reference, subsequent revisions do apply.
- A non-specific reference to an ETS shall also be taken to refer to later versions published as an EN with the same number.

- ITC STANDARD PREVIEW
(standards.iteh.ai)
- [1] ETSI EN 301 002-1: "Integrated Services Digital Network (ISDN); Security Tools (SET) procedures; Digital Subscriber Signalling System No. one (DSS1) protocol; Part 1: Protocol specification". [SIST EN 301 002-4 V1.1.3:2005
https://standards.iteh.ai/catalog/standards/sist/2cb79201-b1e0-42f4-924b-6e21b0000000/etsi-en-301-002-4-v1-1-3-2005](https://standards.iteh.ai/catalog/standards/sist/2cb79201-b1e0-42f4-924b-6e21b0000000/etsi-en-301-002-4-v1-1-3-2005)
- [2] ETSI EN 300 196-1: "Integrated Services Digital Network (ISDN); Generic functional protocol for the support of supplementary services; Digital Subscriber Signalling System No. one (DSS1) protocol; Part 1: Protocol specification".
- [3] ETSI EN 301 002-3: "Integrated Services Digital Network (ISDN); Security Tools (SET) procedures; Digital Subscriber Signalling System No. one (DSS1) protocol; Part 3: Test Suite Structure and Test Purposes (TSS&TP) specification for the user".
- [4] ISO/IEC 9646 (all parts): "Information technology - Open Systems Interconnection - Conformance testing methodology and framework".
- [5] ETSI TR 101 101: "Methods for Testing and Specification (MTS); TTCN interim version including ASN.1 1994 support [ISO/IEC 9646-3] (Second Edition Mock-up for JTC1/SC21 Review)".
- [6] ISO/IEC 8825-1: "Information technology - ASN.1 encoding rules: Specification of Basic Encoding Rules (BER), Canonical Encoding Rules (CER) and Distinguished Encoding Rules (DER)" (see also ITU-T Recommendation X.690 1994).
- [7] ETSI EN 301 002-2: "Integrated Services Digital Network (ISDN); Security Tools (SET) procedures; Digital Subscriber Signalling System No. one (DSS1) protocol; Part 2: Protocol Implementation Conformance Statement (PICS) proforma specification".

3 Definitions and abbreviations

3.1 Definitions

For the purposes of the present document, the terms and definitions given in ISO/IEC 9646 [4] apply.

3.2 Abbreviations

For the purposes of the present document, the following abbreviations apply:

ATS	Abstract Test Suite
BER	Basic Encoding Rules
ETS	Executable Test Suite
IUT	Implementation Under Test
LT	Lower Tester
MOT	Means Of Testing
PCO	Point of Control and Observation
PCTR	Protocol Conformance Test Report
PDU	Protocol Data Unit
PICS	Protocol Implementation Conformance Statement
PIXIT	Protocol Implementation eXtra Information for Testing
SET	Security Tools
SUT	System Under Test
TP	Test Purpose
TTCN	Tree and Tabular Combined Notation

Iteh STANDARD PREVIEW
(standards.iteh.ai)

4 Abstract Test Method

The remote test method is applied for the SET user-ATS.

A Point of Control and Observation (PCO) resides at the service access point between layers 2 and 3 in the test system. This PCO is named "L" (for Lower). The L PCO is used to control and observe the behaviour of the Implementation Under Test (IUT) and test case verdicts are assigned depending on the behaviour observed at this PCO.

A second "informal" PCO, called "O" (for Operator) is used to specify control but not observation above the IUT; events at this PCO are never used to generate test case verdicts. Messages sent by the tester at this PCO explicitly indicate to the operator actions which are to be performed on the SUT. This is regarded as a preferred alternative to the use of the implicit send event.

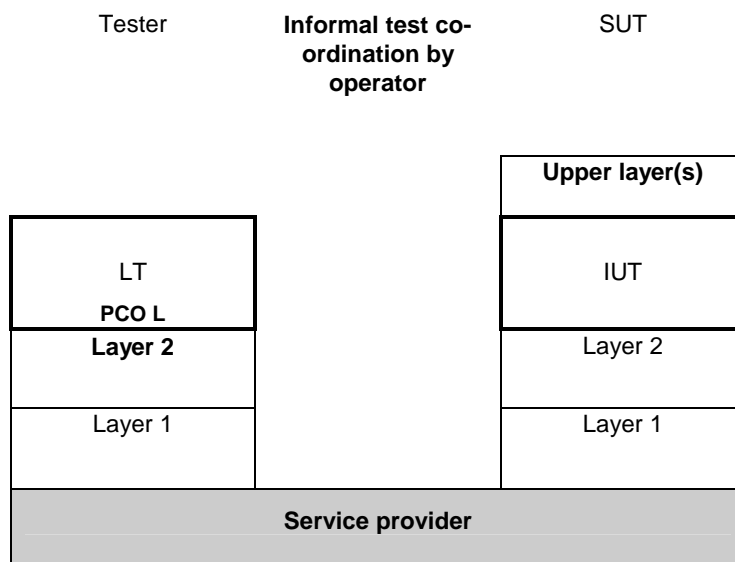

Figure 1: Remote test method with PCO O for test co-ordination

5 Untestable test purposes

There are no untestable test purposes associated with this ATS.

iTeh STANDARD PREVIEW

6 ATS conventions

(standards.iteh.ai)

6.1 Version of TTCN used

SIST EN 301 002-4 V1.1.3:2005

<http://standards.iteh.ai/en/standards/sist/2cb79201-b1e0-42f4-924b-92cb004aa592/sist-en-301-002-4-v1-1-3-2005>

The version of TTCN used is that defined in TR 101 101 [5].

6.2 Use of ASN.1

6.2.1 Situations where ASN.1 is used

ASN.1 has been used for three major reasons. First, types defined in ASN.1 can model problems that "pure" TTCN cannot. For instance, data structures modelling ordered or unordered sequences of data are preferably defined in ASN.1. Second, ASN.1 provides a better restriction mechanism for type definitions by using sub-type definitions. Third, it is necessary to use ASN.1 to reproduce the type definitions for remote operation components specified in the base standards in ASN.1.

The possibility to use TTCN and ASN.1 in combination is used, i.e. referring to an ASN.1 type from a TTCN type.

6.2.2 Specification of encoding rules

There is a variation in the encoding rules applied to ASN.1 types and constraints specified in this ATS and therefore a mechanism is needed to differentiate the encoding rules. However the mechanism specified in ISO/IEC 9646-3/AM2 [4] and in TR 101 101 [5] does not facilitate definition of the encoding rules as needed for this ATS. A solution is therefore used which is broadly in the spirit of ISO/IEC 9646-3/AM2 [4] in which comment fields have been used as a means of encoding rules.

For ASN.1 used in this ATS, two variations of encoding rules are used. One is the commonly known Basic Encoding Rules (BER) as specified in ISO/IEC 8825-1 [6]. In the second case the encoding is according to ISDN, i.e. the ASN.1 data types are a representation of structures contained within the ISDN specification (basic call, Generic functional protocol or individual supplementary service). For example, if octets of an information element are specified in ASN.1 as a SEQUENCE then this should be encoded in an Executable Test Suite (ETS) as any other ISDN information element specified using tabular TTCN. This ISDN encoding variation is the default encoding rule for this ATS. This means that all ASN.1 constraint tables are encoded using ISDN (non-BER) encoding unless stated otherwise. BER encoding should never be applied to an ASN.1 constraint where BER encoding has not been specified. This encoding rule is sometimes named "Direct Encoding".

For BER encoding, an indication is given in the comments field of the table header. For this ATS such indications appear in the ASN.1 type constraint declaration tables only. In the first line of the table header comment field, the notation "ASN1_Encoding: *BER*" is used.

NOTE: Within BER, there are a number of variations for the encoding of lengths of fields. According to EN 300 196-1 [2], an IUT should be able to interpret all length forms within BER for received PDUs. When sending PDUs containing BER encoding, EN 300 196-1 [2] gives guidelines but makes no restrictions on the length forms within BER which an IUT may apply.

In this particular ATS all ASN.1 type constraints which are of type "Component" are to be encoded using BER.

Table 1: ASN.1 type constraint declaration showing use of encoding variation

ASN.1 Type Constraint Declaration	
Constraint Name:	ModifyPinInv1
ASN.1 Type:	Component
Derivation Path:	
Comments:	ASN1_Encoding: BER SET ModifyPin Invoke component
	Description
modifyPin_Components	
modifyPin_InvokeComp	
{ invokeID ?,	SIST EN 301 002-4 V1.1.3:2005
operation_value	https://standards.iteh.ai/catalog/standards/sist/2cb79201-b1e0-42f4-924b-92cb004aa592/sist-en-301-002-4-v1-1-3-2005
globalValue modifyPin,	
argument {	
oldPin ?,	
newPin ?,	
servedUserNr ?	
}	
}	
Detailed comments:	

7 ATS to TP map

The identifiers used for the TPs are reused as test case names (see EN 301 002-3 [3]). Thus there is a straightforward one-to-one mapping.

8 PCTR conformance

A test laboratory, when requested by a client to produce a PCTR, is required, as specified in ISO/IEC 9646-5 [4], to produce a PCTR conformant with the PCTR template given in annex B of ISO/IEC 9646-5 [4].