

ETSI GS MEC 003 V3.2.1 (2024-04)



Multi-access Edge Computing (MEC); Framework and Reference Architecture

(<https://standards.iteh.ai>)

Document Preview

[ETSI GS MEC 003 V3.2.1 \(2024-04\)](https://standards.iteh.ai/catalog/standards/etsi/0f2ef00c-7267-4177-a89d-461610cfd0aa/etsi-gs-mec-003-v3-2-1-2024-04)

<https://standards.iteh.ai/catalog/standards/etsi/0f2ef00c-7267-4177-a89d-461610cfd0aa/etsi-gs-mec-003-v3-2-1-2024-04>

Disclaimer

The present document has been produced and approved by the Multi-access Edge Computing (MEC) ETSI Industry Specification Group (ISG) and represents the views of those members who participated in this ISG. It does not necessarily represent the views of the entire ETSI membership.

Reference

RGS/MEC-0003v321Arch

Keywords

architecture, MEC

ETSI

650 Route des Lucioles
F-06921 Sophia Antipolis Cedex - FRANCE

Tel.: +33 4 92 94 42 00 Fax: +33 4 93 65 47 16

Siret N° 348 623 562 00017 - APE 7112B
Association à but non lucratif enregistrée à la
Sous-Préfecture de Grasse (06) N° w061004871

Important notice

The present document can be downloaded from:
<https://www.etsi.org/standards-search>

The present document may be made available in electronic versions and/or in print. The content of any electronic and/or print versions of the present document shall not be modified without the prior written authorization of ETSI. In case of any existing or perceived difference in contents between such versions and/or in print, the prevailing version of an ETSI deliverable is the one made publicly available in PDF format at www.etsi.org/deliver.

Users of the present document should be aware that the document may be subject to revision or change of status. Information on the current status of this and other ETSI documents is available at <https://portal.etsi.org/TB/ETSIDeliverableStatus.aspx>

If you find errors in the present document, please send your comment to one of the following services:
<https://portal.etsi.org/People/CommitteeSupportStaff.aspx>

If you find a security vulnerability in the present document, please report it through our Coordinated Vulnerability Disclosure Program:
<https://www.etsi.org/standards/coordinated-vulnerability-disclosure>

Notice of disclaimer & limitation of liability

The information provided in the present deliverable is directed solely to professionals who have the appropriate degree of experience to understand and interpret its content in accordance with generally accepted engineering or other professional standard and applicable regulations.

No recommendation as to products and services or vendors is made or should be implied.

No representation or warranty is made that this deliverable is technically accurate or sufficient or conforms to any law and/or governmental rule and/or regulation and further, no representation or warranty is made of merchantability or fitness for any particular purpose or against infringement of intellectual property rights.

In no event shall ETSI be held liable for loss of profits or any other incidental or consequential damages.

Any software contained in this deliverable is provided "AS IS" with no warranties, express or implied, including but not limited to, the warranties of merchantability, fitness for a particular purpose and non-infringement of intellectual property rights and ETSI shall not be held liable in any event for any damages whatsoever (including, without limitation, damages for loss of profits, business interruption, loss of information, or any other pecuniary loss) arising out of or related to the use of or inability to use the software.

Copyright Notification

No part may be reproduced or utilized in any form or by any means, electronic or mechanical, including photocopying and microfilm except as authorized by written permission of ETSI.

The content of the PDF version shall not be modified without the written authorization of ETSI.
The copyright and the foregoing restriction extend to reproduction in all media.

© ETSI 2024.
All rights reserved.

Contents

Intellectual Property Rights	5
Foreword.....	5
Modal verbs terminology.....	5
1 Scope	6
2 References	6
2.1 Normative references	6
2.2 Informative references.....	6
3 Definition of terms, symbols and abbreviations.....	7
3.1 Terms.....	7
3.2 Symbols.....	7
3.3 Abbreviations	7
4 Overview	7
5 Multi-access Edge Computing framework.....	8
6 Reference architecture.....	9
6.1 Generic reference architecture.....	9
6.2 Reference architecture variant for MEC in NFV.....	10
6.2.1 Description.....	10
6.2.2 Architecture diagram	10
6.3 Reference architecture variant for MEC federation.....	11
6.3.1 Description.....	11
6.3.2 Architecture diagram	12
7 Functional elements and reference points	12
7.1 Functional elements.....	12
7.1.1 MEC host.....	12
7.1.2 MEC platform.....	12
7.1.3 MEC application.....	13
7.1.4 MEC system level management.....	13
7.1.4.1 MEC orchestrator.....	13
7.1.4.2 Operations Support System (OSS).....	13
7.1.4.3 User application lifecycle management proxy	14
7.1.5 MEC host level management.....	14
7.1.5.1 MEC platform manager.....	14
7.1.5.2 Virtualisation infrastructure manager.....	14
7.1.6 Device application	14
7.1.7 Customer facing service portal	15
7.1.8 Specific functional elements in the MEC in NFV architecture variant.....	15
7.1.8.1 Overview	15
7.1.8.2 MEC application orchestrator	15
7.1.8.3 MEC platform manager - NFV	15
7.1.8.4 NFVO.....	15
7.1.8.5 VNFM (MEC platform LCM).....	15
7.1.8.6 VNFM (MEC application LCM).....	15
7.1.9 MEC federator	15
7.2 Reference points	16
7.2.1 Reference points related to the MEC platform	16
7.2.2 Reference points related to the MEC management.....	16
7.2.3 Reference points related to external entities	17
7.2.4 Reference points related to the MEC in NFV architecture variant	17
7.2.5 Reference points related to the MEC federation architecture variant	17
8 MEC services	18
8.1 General	18
8.2 Radio Network Information	18

8.3	Location.....	18
8.4	Traffic Management Services.....	18
9	Other considerations.....	19
9.1	Inter-MEC system communication.....	19
9.2	Security of the Mp3 reference point.....	19
Annex A (informative): Key concepts.....		20
A.1	MEC host selection	20
A.2	DNS support.....	20
A.3	Application traffic filtering and routing	21
A.4	Support of application and UE mobility.....	21
A.4.1	Background: UE mobility	21
A.4.2	MEC application scenarios for UE mobility	21
A.4.2.1	MEC applications not sensitive to UE mobility.....	21
A.4.2.2	MEC applications sensitive to UE mobility.....	21
A.4.2.2.1	Maintaining connectivity between UE and MEC application instance	21
A.4.2.2.2	Application state relocation.....	21
A.4.2.2.3	Application instance relocation within the MEC system	22
A.4.2.2.4	Application instance relocation between the MEC system and an external cloud environment	22
A.5	Void.....	22
A.6	Data Plane	22
A.7	API gateway support.....	22
Annex B (informative): Relationship with 3GPP SA6 EDGEAPP architecture		23
B.1	Introduction	23
B.2	Edge Enabler Server (EES)	23
Annex C (informative): Relationship with GSMA OP architecture.....		25
C.1	Introduction	25
C.2	E/WBI.....	26
C.3	NBI.....	26
Annex D (informative): Relationship with both 3GPP SA6 EDGEAPP and GSMA OP reference points.....		27
History		29

Intellectual Property Rights

Essential patents

IPRs essential or potentially essential to normative deliverables may have been declared to ETSI. The declarations pertaining to these essential IPRs, if any, are publicly available for **ETSI members and non-members**, and can be found in ETSI SR 000 314: "*Intellectual Property Rights (IPRs); Essential, or potentially Essential, IPRs notified to ETSI in respect of ETSI standards*", which is available from the ETSI Secretariat. Latest updates are available on the ETSI Web server (<https://ipr.etsi.org/>).

Pursuant to the ETSI Directives including the ETSI IPR Policy, no investigation regarding the essentiality of IPRs, including IPR searches, has been carried out by ETSI. No guarantee can be given as to the existence of other IPRs not referenced in ETSI SR 000 314 (or the updates on the ETSI Web server) which are, or may be, or may become, essential to the present document.

Trademarks

The present document may include trademarks and/or tradenames which are asserted and/or registered by their owners. ETSI claims no ownership of these except for any which are indicated as being the property of ETSI, and conveys no right to use or reproduce any trademark and/or tradename. Mention of those trademarks in the present document does not constitute an endorsement by ETSI of products, services or organizations associated with those trademarks.

DECT™, **PLUGTESTS™**, **UMTS™** and the ETSI logo are trademarks of ETSI registered for the benefit of its Members. **3GPP™** and **LTE™** are trademarks of ETSI registered for the benefit of its Members and of the 3GPP Organizational Partners. **oneM2M™** logo is a trademark of ETSI registered for the benefit of its Members and of the oneM2M Partners. **GSM®** and the GSM logo are trademarks registered and owned by the GSM Association.

Foreword

This Group Specification (GS) has been produced by ETSI Industry Specification Group (ISG) Multi-access Edge Computing (MEC).

Modal verbs terminology

In the present document "**shall**", "**shall not**", "**should**", "**should not**", "**may**", "**need not**", "**will**", "**will not**", "**can**" and "**cannot**" are to be interpreted as described in clause 3.2 of the [ETSI Drafting Rules](#) (Verbal forms for the expression of provisions).

"**must**" and "**must not**" are **NOT** allowed in ETSI deliverables except when used in direct citation.

1 Scope

The present document provides a framework and reference architecture for Multi-access Edge Computing that describes a MEC system that enables MEC applications to run efficiently and seamlessly in a multi-access network. The present document also describes the functional elements and the reference points between them, and a number of MEC services that comprise the solution. It finally presents a number of key concepts related to the multi-access edge architecture.

2 References

2.1 Normative references

References are either specific (identified by date of publication and/or edition number or version number) or non-specific. For specific references, only the cited version applies. For non-specific references, the latest version of the referenced document (including any amendments) applies.

Referenced documents which are not found to be publicly available in the expected location might be found at <https://docbox.etsi.org/Reference/>.

NOTE: While any hyperlinks included in this clause were valid at the time of publication, ETSI cannot guarantee their long term validity.

The following referenced documents are necessary for the application of the present document.

- [1] [ETSI GS MEC 002](#): "Multi-access Edge Computing (MEC); Use Cases and Requirements".
- [2] [ETSI GS NFV 002](#): "Network Functions Virtualisation (NFV); Architectural Framework".
- [3] [ETSI GS NFV-IFA 013](#): "Network Functions Virtualisation (NFV); Management and Orchestration; Os-Ma-nfvo reference point - Interface and Information Model Specification".
- [4] [ETSI GS NFV-IFA 008](#): "Network Functions Virtualisation (NFV); Management and Orchestration; Ve-Vnfm reference point - Interface and Information Model Specification".
- [5] [ETSI GS MEC 009](#): "Multi-access Edge Computing (MEC); General principles, patterns and common aspects of MEC Service APIs".
- [6] [ETSI GS MEC 040](#): "Multi-access Edge Computing (MEC); Federation enablement APIs".

2.2 Informative references

References are either specific (identified by date of publication and/or edition number or version number) or non-specific. For specific references, only the cited version applies. For non-specific references, the latest version of the referenced document (including any amendments) applies.

NOTE: While any hyperlinks included in this clause were valid at the time of publication, ETSI cannot guarantee their long term validity.

The following referenced documents are not necessary for the application of the present document but they assist the user with regard to a particular subject area.

- [i.1] ETSI GR MEC 001: "Multi-access Edge Computing (MEC); Terminology".
- [i.2] Void.
- [i.3] OpenStack®: "[OpenStack++ for Cloudlet Deployment](#)".

NOTE: The OpenStack® Word Mark and OpenStack Logo are either registered trademarks/service marks or trademarks/service marks of the OpenStack Foundation, in the United States and other countries and are used with the OpenStack Foundation's permission. ETSI is not affiliated with, endorsed or sponsored by the OpenStack Foundation, or the OpenStack community.

- [i.4] Void.
- [i.5] ETSI GR MEC 017: "Mobile Edge Computing (MEC); Deployment of Mobile Edge Computing in an NFV environment".
- [i.6] ETSI TS 123 501: "5G; System architecture for the 5G System (5GS) (3GPP TS 23.501 Release 17)".
- [i.7] ETSI GR MEC 035: "Multi-access Edge Computing (MEC); Study on Inter-MEC systems and MEC-Cloud systems coordination".
- [i.8] [GSMA Official Document OPG.02](#): "Operator Platform: Requirements and Architecture", v6.0, February 2024.
- [i.9] ETSI TS 123 558: "5G; Architecture for enabling Edge Applications (3GPP TS 23.558 Release 17)".
- [i.10] ETSI TS 133 310: "Universal Mobile Telecommunications System (UMTS); LTE; 5G; Network Domain Security (NDS); Authentication Framework (AF) (3GPP TS 33.310 Release 17)".

3 Definition of terms, symbols and abbreviations

3.1 Terms

For the purposes of the present document, the terms given in ETSI GR MEC 001 [i.1] apply.

3.2 Symbols

Void.

3.3 Abbreviations

For the purposes of the present document, the abbreviations given in ETSI GR MEC 001 [i.1] and the following apply:

CFS	Customer Facing Service
-----	-------------------------

4 Overview

The present document presents a framework and a reference architecture to support the requirements defined for Multi-access Edge Computing in ETSI GS MEC 002 [1].

The framework described in clause 5 shows the structure of the Multi-access Edge Computing environment.

The reference architecture described in clause 6 shows the functional elements that compose the multi-access edge system, including the MEC platform and the MEC management, as well as the reference points between them.

The functional elements and reference points listed in clause 7 describe the high-level functionality of the different functional elements and reference points.

Clause 8 describes the high-level functionality of a number of MEC services, comprising the solution for Multi-access Edge Computing.

Annex A describes at a high-level a number of key concepts that underlie the principles used to develop the framework and reference architecture described in the present document.

5 Multi-access Edge Computing framework

Multi-access Edge Computing enables the implementation of MEC applications as software-only entities that run on top of a Virtualisation infrastructure, which is located in or close to the network edge. The Multi-access Edge Computing framework shows the general entities involved. These can be grouped into system level, host level and network level entities.

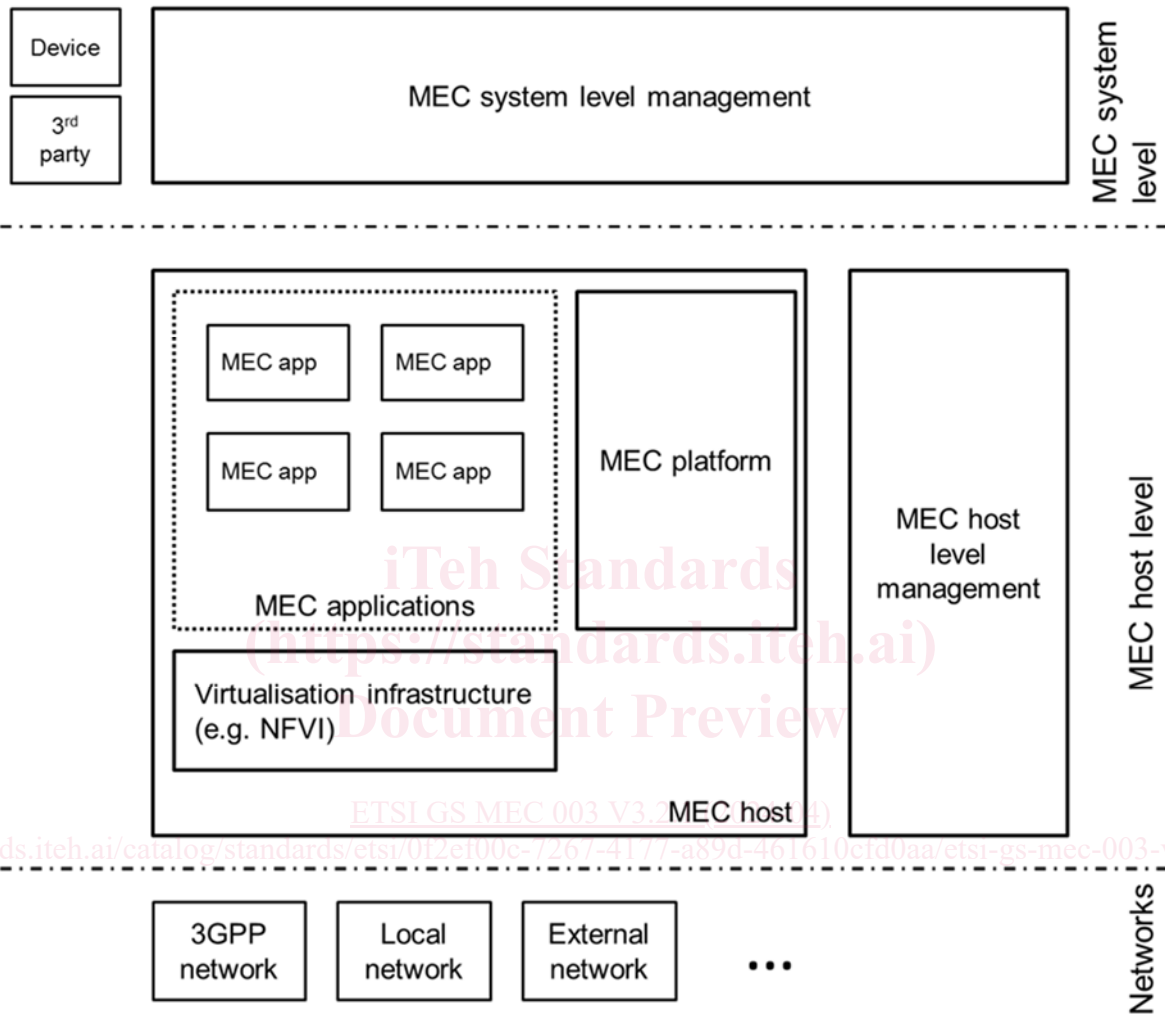

Figure 5-1: Multi-access Edge Computing framework

Figure 5-1 illustrates the framework for Multi-access Edge Computing consisting of the following entities:

- MEC host, including the following:
 - MEC platform;
 - MEC applications;
 - virtualisation infrastructure;
- MEC system level management;
- MEC host level management;
- external related entities, i.e. network level entities.

6 Reference architecture

6.1 Generic reference architecture

The reference architecture shows the functional elements that comprise the multi-access edge system and the reference points between them.

Figure 6-1 depicts the generic multi-access edge system reference architecture. There are three groups of reference points defined between the system entities:

- reference points regarding the MEC platform functionality (Mp);
- management reference points (Mm); and
- reference points connecting to external entities (Mx).

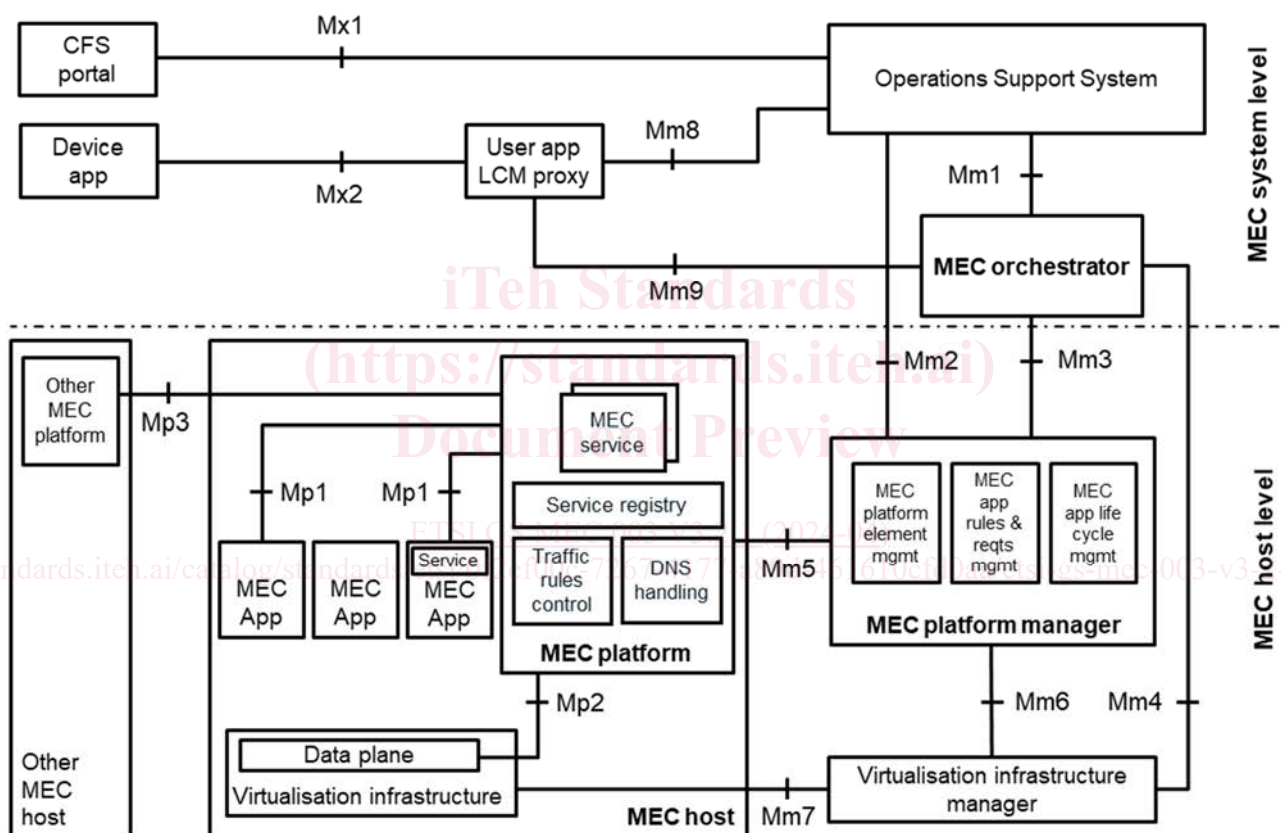

Figure 6-1: Multi-access edge system reference architecture

The multi-access edge system consists of the MEC hosts and the MEC management necessary to run MEC applications within an operator network or a subset of an operator network.

The **MEC host** is an entity that contains a MEC platform and a Virtualisation infrastructure which provides compute, storage, and network resources, for the purpose of running MEC applications. The MEC host is further described in clause 7.1.1.

The **MEC platform** is the collection of essential functionality required to run MEC applications on a particular Virtualisation infrastructure and enable them to provide and consume MEC services. The MEC platform can also provide services. The MEC platform is further described in clause 7.1.2.

MEC applications are instantiated and run on the Virtualisation infrastructure based on configuration or based on requests validated by the MEC management. MEC applications are further described in clause 7.1.3.

The MEC management comprises the MEC system level management and the MEC host level management.

The MEC system level management includes the **MEC orchestrator** as its core component, which has an overview of the complete MEC system. The MEC system level management is further described in clause 7.1.4.

The MEC host level management comprises the **MEC platform manager** and the **Virtualisation infrastructure manager**, and handles the management of the MEC specific functionality of a particular MEC host and the applications running on it. The MEC host level management is further described in clause 7.1.5.

6.2 Reference architecture variant for MEC in NFV

6.2.1 Description

MEC and Network Functions Virtualisation (NFV) are complementary concepts. The MEC architecture has been designed in such a way that a number of different deployment options of MEC systems are possible. A dedicated Group Report, ETSI GR MEC 017 [i.5], provides an analysis of solution details of the deployment of MEC in an NFV environment.

In clauses 6.2.2, 7.1.8 and 7.2.4 of the present document, a MEC architecture variant is specified that allows to instantiate MEC applications and NFV virtualised network functions on the same Virtualisation infrastructure, and to re-use ETSI NFV MANO components to fulfil a part of the MEC management and orchestration tasks.

6.2.2 Architecture diagram

Figure 6-2 depicts a variant of the multi-access edge system reference architecture for the deployment in an NFV environment [2].

In addition to the definitions for the generic reference architecture in clause 6.1, the following new architectural assumptions apply:

- The MEC platform is deployed as a VNF.
- The MEC applications appear as VNFs towards the ETSI NFV MANO components.
- The Virtualisation infrastructure is deployed as an NFVI and is managed by a VIM as defined by ETSI GS NFV 002 [2].
- The MEC Platform Manager (MEPM) is replaced by a MEC platform manager - NFV (MEPM-V) that delegates the VNF lifecycle management to one or more VNF Managers (VNFMs).
- The MEC Orchestrator (MEO) is replaced by a MEC Application Orchestrator (MEAO) that relies on the NFV Orchestrator (NFVO) for resource orchestration and for orchestration of the set of MEC application VNFs as one or more NFV Network Services (NSs).

The new reference points shown in figure 6-2 are further described in clause 7.2.4.