



Designation: ~~D2113-06~~ Designation: D 2113 – 08

## Standard Practice for Rock Core Drilling and Sampling of Rock for Site Investigation<sup>1</sup>

This standard is issued under the fixed designation D 2113; the number immediately following the designation indicates the year of original adoption or, in the case of revision, the year of last revision. A number in parentheses indicates the year of last reapproval. A superscript epsilon ( $\epsilon$ ) indicates an editorial change since the last revision or reapproval.

*This standard has been approved for use by agencies of the Department of Defense.*

### 1. Scope\*

1.1 This practice covers the guidelines, requirements, and procedures for core drilling, coring, and sampling of rock for the purposes of site investigation. The borehole could be vertical, horizontal, or angled.

1.2 This practice is described in the context of obtaining data for the design, construction, or maintenance of structures, and applies to surface drilling and drilling from adits and exploratory tunnels.

1.3 This practice applies to core drilling in hard and soft rock.

1.4 This practice does not address considerations for core drilling for geo-environmental site characterization and installation of water quality monitoring devices (see Guides D 5782 and D 5783).

~~1.5 The values stated in inch-pound units are to be regarded as standard. The SI values given in parentheses are provided for information purposes only.~~

1.5 The values stated in inch-pound units are to be regarded as standard. The values given in parentheses are mathematical conversions to SI units that are provided for information only and are not considered standard.

1.6 This practice does not purport to comprehensively address all of the methods and the issues associated with coring and sampling of rock. Users should seek qualified professionals for decisions as to the proper equipment and methods that would be most successful for their site investigation. Other methods may be available for drilling and sampling of rock, and qualified professionals should have flexibility to exercise judgment as to possible alternatives not covered in this practice. This practice is current at the time of issue, but new alternative methods may become available prior to revisions; therefore, users should consult with manufacturers or producers prior to specifying program requirements. *This practice offers a set of instructions for performing one or more specific operations. This document cannot replace education or experience and should be used in conjunction with professional judgment. Not all aspects of this practice may be applicable in all circumstances. This ASTM standard is not intended to represent or replace the standard of care by which the adequacy of a given professional service must be judged, nor should this document be applied without consideration of a project's many unique aspects. The word "Standard" in the title of this document means only that the document has been approved through the ASTM consensus process.* [344951ba63/astm-d2113-08](https://doi.org/10.1520/344951ba63/astm-d2113-08)

1.7 *This standard does not purport to address all of the safety concerns, if any, associated with its use. It is the responsibility of the user of this standard to establish appropriate safety and health practices and determine the applicability of regulatory limitations prior to use.* Also, the user must comply with prevalent regulatory codes, such as OSHA (Occupational Health and Safety Administration) guidelines, while using this practice. For good safety practice, consult applicable OSHA regulations and other safety guides on drilling (1) .

### 2. Referenced Documents

#### 2.1 ASTM Standards:<sup>2</sup>

D 420 Guide to Site Characterization for Engineering Design and Construction Purposes

D 653 Terminology Relating to Soil, Rock, and Contained Fluids

D 4380 Test Method for Density of Bentonitic Slurries

D 4630 Test Method for Determining Transmissivity and Storage Coefficient of Low-Permeability Rocks by In Situ Measurements Using the Constant Head Injection Test

D 5079 Practices for Preserving and Transporting Rock Core Samples

<sup>1</sup> This Practice is under the jurisdiction of ASTM Committee D18 on Soil and Rock and is the direct responsibility of Subcommittee D18.02 on Sampling and Related Field Testing for Soil Evaluations.

Current edition approved May 1, 2006. Published June 2006. Originally approved in 1962. Last previous edition approved in 1999 as D2113-99.

Current edition approved Oct. 1, 2008. Published October 2008. Originally approved in 1962. Last previous edition approved in 2006 as D 2113 – 06.

<sup>2</sup> For referenced ASTM standards, visit the ASTM website, [www.astm.org](http://www.astm.org), or contact ASTM Customer Service at [service@astm.org](mailto:service@astm.org). For *Annual Book of ASTM Standards* volume information, refer to the standard's Document Summary page on the ASTM website.

\*A Summary of Changes section appears at the end of this standard.

- D 5434 Guide for Field Logging of Subsurface Explorations of Soil and Rock
- D 5782 Guide for Use of Direct Air-Rotary Drilling for Geoenvironmental Exploration and the Installation of Subsurface Water-Quality Monitoring Devices
- D 5783 Guide for Use of Direct Rotary Drilling with Water-Based Drilling Fluid for Geoenvironmental Exploration and the Installation of Subsurface Water-Quality Monitoring Devices
- D 5876 Guide for Use of Direct Rotary Wireline Casing Advancement Drilling Methods for Geoenvironmental Exploration and Installation of Subsurface Water-Quality Monitoring Devices
- D 6032 Test Method for Determining Rock Quality Designation (RQD) of Rock Core
- D 6151 Practice for Using Hollow-Stem Augers for Geotechnical Exploration and Soil Sampling
- 2.2 *American Petroleum Institute Standard:*<sup>3</sup>
- API RP 13B Recommended Practice Standard Procedure for Testing Drilling Fluids
- 2.3 *NSF Standard:*<sup>4</sup>
- NSF 60-1988 Drinking Water Treatment Chemicals-Health Effects

### 3. Terminology

- 3.1 For common definitions of terms in this standard, refer to Terminology D 653.
- 3.2 *Definitions:*
- 3.2.1 *blind hole, n*—borehole that yields no fluid recovery of the drilling fluids.
- 3.2.2 *casing, n*—hollow tubes of steel used to support borehole walls or where fluid losses must be stopped.
- 3.2.3 *caving hole, n*—borehole whose walls or bottom are unstable and cave or collapse into the drilled borehole.
- 3.2.4 *core barrel, n*—hollow tube of steel used to collect cores of drilled rock.
- 3.2.5 *core bit, n*—a drill bit that cuts cylindrical rock samples and consists of one of the following: a drill bit with surface set of diamonds or impregnated diamonds in a tungsten carbide mix of hardened steel, polycrystalline bit, or tungsten carbide (TC) inserts mounted on a cylindrical bit that cuts out cylindrical rock samples.
- 3.2.6 *drill rig, n*—includes drilling power unit, mast or derrick, circulating pumps, and mounting platform.
- 3.2.7 *drill rod, n*—hollow steel tubes that are connected to the drill bit or core barrel and to the rotary head of the drilling power unit.
- 3.2.8 *drill platform, n*—a platform for a drilling rig.
- 3.2.9 *overshot, n*—a latching mechanism at the end of the hoisting line, specially designed to latch onto or release pilot bit or core barrel assemblies when using *wireline drilling*. **(D 5876)**
- 3.2.10 *pilot bit assembly, n*—designed to lock into the end section of drill rod for *wireline drilling* without sampling. The pilot bit can be either drag, roller cone, or diamond plug types. The bit can be set to protrude from the rod coring bit depending on the formation being drilled. **(D 5876)**
- 3.2.11 *squeezing hole, n*—borehole whose walls move into the drilled opening and squeeze on the drill rods.
- 3.2.12 *wireline, n*—a cable made of steel strands connected to a drum hoist, used to raise and lower the core barrel, drill rods, or other equipment as needed in the drill hole.
- 3.2.13 *wireline drilling, n*—a rotary drilling process using special enlarged inside diameter drilling rods with special latching pilot bits or core barrels raised or lowered inside the rods with a wireline and overshot latching mechanism. **(D 5876)**

### 4. Summary of Practice

#### 4.1 *Drilling:*

4.1.1 Drilling is accomplished by circulating a drilling medium through the drill bit while rotating and lowering or advancing the string of drill rods as downward force is applied to a cutting bit. The bit cuts and breaks up the material as it penetrates the formation, and the drilling medium picks up the cuttings generated by the cutting action of the bit. The drilling medium, with cuttings, then flows outward through the annular space between the drill rods and drill hole, and carries the cuttings to the ground surface, thus cleaning the hole. The string of drill rods and bit is advanced downward, deepening the hole as the operation proceeds.

4.1.1.1 Fluid drilling is accomplished by circulating water or a water-based fluid with additives. Additives such as bentonite or polymers are frequently added to water to lubricate and cool the bit and to circulate (transport) cuttings to the surface. Drill fluid can also act to prevent cave or collapse of the drill hole. After the drilling fluid reaches the surface, it flows to a ditch or effluent pipe and into a settling pit where the cuttings settle to the bottom. Cuttings are sometimes run through a shaker to remove the larger particles. From the settling pit, the drilling fluid overflows into the main pit, from which it is picked up by the suction line of the mud pump and recirculated through the drill string.

NOTE 1—The decrease of mud velocity upon entering the mud pit may cause gelling of the mud and prevent cuttings from settling. Agitation of the mud in the pit can remedy the problem.

<sup>2</sup> Available from American Petroleum Institute, 2101 L St. NW, Washington, DC

<sup>3</sup> Available from American Petroleum Institute (API), 1220 L. St., NW, Washington, DC 20005-4070, <http://www.api.org>.

<sup>4</sup> Available from NSF International, P.O. Box 130140, Ann Arbor, MI 48113-0140.

<sup>4</sup> Available from NSF International, P.O. Box 130140, 789 N. Dixboro Rd., Ann Arbor, MI 48113-0140, <http://www.nsf.org>.

4.1.1.2 Air drilling is performed where introduction of fluids is undesirable. Air rotary drilling requires use of an air compressor with volume displacement large enough to develop sufficient air velocity to remove cuttings. Cuttings can be collected at the surface in cyclone separators. Sometimes a small amount of water or foam may be added to the air to enhance return of cuttings. Air drilling may not be satisfactory in unconsolidated and cohesionless soils under the ground water table.

4.2 *Coring:*

4.2.1 Coring is the process of recovering cylindrical cores of rock by means of rotating a hollow steel tube (core barrel) equipped with a coring bit. The drilled core is carefully collected in the core barrel as the drilling progresses.

4.3 *Sampling:*

4.3.1 Once the core has been cut and the core barrel is full, the drill rods or overshot assembly are pulled and the core retrieved. Samples are packaged and shipped for testing (see Practices D 5079).

5. Significance and Use

5.1 Rock cores are samples of record of the existing subsurface conditions at given borehole locations. The samples are expected to yield significant indications about the geological, physical, and engineering nature of the subsurface for use in the design and construction of an engineered structure (see Guide D 420). The core samples need to be preserved using specific procedures for a stipulated time (Practices D 5079). The period of storage depends upon the nature and significance of the engineered structure.

5.2 Rock cores always need to be handled such that their properties are not altered in any way due to mechanical damage or changes in ambient conditions of moisture and temperature or other environmental factors.

6. Apparatus

6.1 *General*—Fig. 1 shows the schematic of a typical rock core drill setup (2). Essential components of the drilling equipment include the drilling rig with rotary power, hoisting systems, casing, rods, core barrels, including bits and liners, and pumps with circulating system. In addition, equipment should include necessary tools for hoisting and coupling and uncoupling the drill string and other miscellaneous items such as prefabricated mud pits and racks for rod stacking and layout. Normally, a drilling platform of planking is built up around the drilling site.

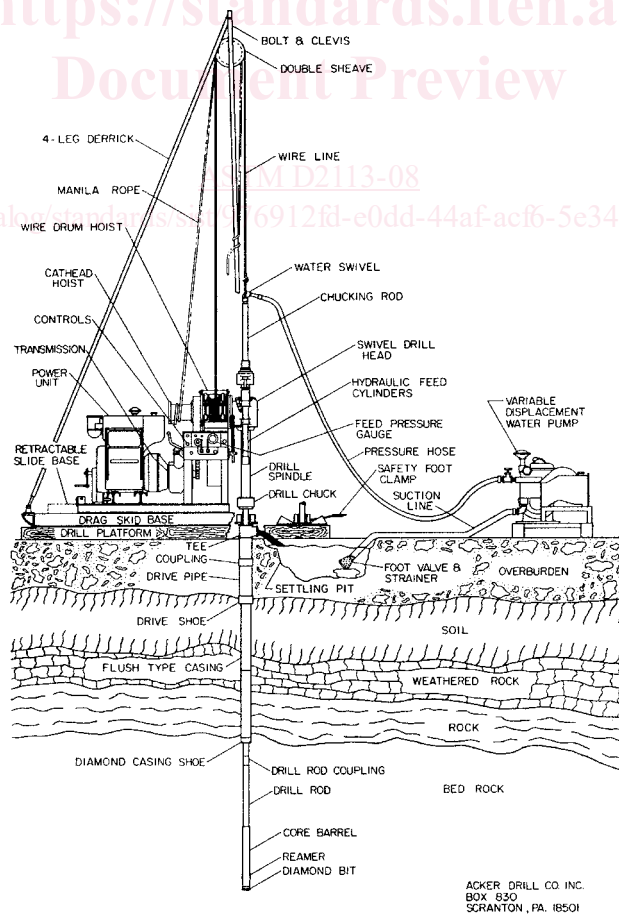

FIG. 1 Schematic of Typical Diamond Core Drill Set-up (2)

6.1.1 Rock coring operations can proceed at high rotation rates. It is imperative the drill rig, rods, and core barrels are straight and have a balanced center of gravity to avoid whipping and resulting damage to cores and expensive bits.

6.2 *Drilling Rig*— The drill rig provides the rotary power and downward (or advance) force or hold-back force on the core barrel to core the rock. The preferred diamond drill coring equipments are designs with hydraulic or gear-driven variable speed hollow spindle rotary drill heads, although some core rigs are manufactured with gear or chain pulldown/retract systems. Precise control over bit pressure can best be accomplished by a variable setting hydraulic pulldown/retract system. Hydraulic systems are often equipped with a detent valve, which allows downfeed (or advance) rate to be set at a certain speed regardless of tool weight or down pressure exerted on the coring bit. Hydraulic feed drill rigs should be supplied with a hydraulic pressure gauge that can be related to bit pressures. Deep hole drill rigs should be equipped with hydraulic hold-back control so, if required, the full weight of the drill rods is not exerted on the bit when drilling downward. Diamond drill rigs can apply high rotation rates as high as 1000 rpm as opposed to normal rotary drills operating at 60 to 120 rpm (3). Most diamond core drills are equipped with a mast and powered hoist for hoisting heavy drill strings. A second wireline hoist is helpful for wireline drilling.

6.2.1 The drill rig frame is either skid or truck mounted and should be equipped with a slide base for ease in working around the drill hole. In special cases, the drilling rig may be mounted on a trailer, barge (for overwater drilling), or columns (for underground work). Some drill rigs are designed to be broken down into several pieces for transport into remote areas. The drilling rig power unit may be powered by hydraulics, air, electricity, gas, or diesel. Most surface skid or truck mounted rigs are diesel or gas powered.

6.2.2 Drilling directions are rarely vertical in underground applications, and smaller rigs are frequently equipped with swivel heads to accommodate drilling at angles. Special accommodations must be made for holding and breaking rods when drilling at high angles into crowns of adits. Either top drive drill or column mount machines with hydraulic or pneumatic rod jacks are equipped to handle up holes. For confined space drilling operations, drills are column mounted or mounted on small skids. Special power sources may be required for underground work due to air quality considerations. Remote power pack stations usually electric, hydraulic, compressed air, or a combination of the three. Electrically powered hydraulic systems are most common in underground use today.

6.2.3 The platform may need to be constructed at the drilling site to provide a firm base upon which the drill rig is then placed. Platforms are also constructed in the vicinity of the drill hole for workers to hold equipment, serve as a datum, and to allow safe operations.

### 6.3 *Fluid or Air Circulation Systems* :

6.3.1 *Selection of Drill Media*—The two primary methods for circulating drill cuttings are water or water-based fluids or air with or without additives. The predominant method of drilling is water-based fluids. Water-based drilling is effective in a wide range of conditions both above and below the water table. Air drilling is selected when water-sensitive soils such as swelling clays or low density collapsible soils are encountered. Air drilling may also be required above the water table if special testing is required in the unsaturated zone. Air drilling is also convenient in highly fractured igneous rocks and porous formations where water-based fluid losses are unacceptable. The primary functions of the drill fluid are:

- 6.3.1.1 Remove drill cuttings,
- 6.3.1.2 Stabilize the borehole,
- 6.3.1.3 Cool and lubricate the bit,
- 6.3.1.4 Control fluid loss,
- 6.3.1.5 Drop cuttings into a settling pit,
- 6.3.1.6 Facilitate logging of the borehole, and
- 6.3.1.7 Suspend cuttings in the drill hole during coring.

6.3.1.8 No single drill fluid mixture can satisfy all of the above requirements perfectly. In the sections below, considerations for materials that could be used in drilling medium are given.

6.3.2 The pressure hose conducts the drilling fluid or air from the circulation pump or compressor to the swivel.

6.3.3 The swivel directs the drilling fluid or air to a rotating kelly or drill-rod column.

#### 6.3.4 *Rotary Drilling with Water-based Drilling Fluids:*

6.3.4.1 The mud pit is a reservoir for the drilling fluid, and, if properly designed and used, provides sufficient flow velocity reduction to allow separation of drill cuttings from the fluid before recirculation. The mud pit can be a shallow, open metal tank with baffles or an excavated pit with some type of liner, and designed to prevent loss of drilling fluid. The mud pit can be used as a mixing reservoir for the initial quantity of drilling fluid, and, in some circumstances, for adding water and additives to the drilling fluid as drilling progresses. It may be necessary to have additional storage tanks for preparing fluids while drilling progresses.

6.3.4.2 The suction line, sometimes equipped with a foot valve or strainer, or both, conducts the drilling fluid from the mud pit to the fluid circulation pump.

6.3.4.3 The fluid circulation pump must be able to lift the drilling fluid from the mud pit and move it through the system against variable pumping heads at a flow rate to provide an annular velocity that is adequate to transport drill cuttings out of the drill hole.

6.3.4.4 *Water-based Drilling Fluids* —The four main classes of water-based drilling fluids are: (1) clean, fresh water, (2) water with clay (bentonite) additives, (3) water with polymeric additives, and (4) water with both clay and polymer additives. For

commonly used materials added to water-based fluid, see Section 7 on Materials.

(1) Clean fresh water alone is often not acceptable for core drilling due to poor bit lubrication, erosion due to high velocities required for lifting cuttings, and excessive water loss. In water-sensitive soils, it is desirable to use drill additives to form drill hole wall cakes and prevent moisture penetration. In some cases, water may be required for piezometer installations where other fluid additives are not acceptable, but often newer synthetic polymer materials are acceptable for piezometer and well installations.

(2) Bentonitic drill muds are often used in rotary drilling applications. The bentonite should be added to water with vigorous mixing and recirculation to ensure uniform properties and to reach a dispersed deflocculated state. For diamond core drilling, low viscosity is usually required due to small clearances. The viscosity of a fluid-mud mixture is related to the solids content and particle shapes and alignments of the additives. During the high speed rotary drilling process, solids have a tendency to spin out and collect inside drill rods. For diamond drilling, low solids content is desirable. If mass is required to balance high hydrostatic pressures, additives such as barite or ilmenite (see 7.1.8) can be added to keep solids contents low.

(3) The need for low solids contents and good lubrication properties point to the use of polymer drill fluids. Natural or synthetic polymer fluids are the best additives for diamond core drilling. Polymer chains such as those from guar gum exhibit flow thinning characteristics in high velocity and shear conditions. Polymer fluids can be weighted with salts to balance hydrostatic pressures. Detergents or deflocculating agents can be added to discharge lines to assist in dropping cuttings to maintain fluid properties.

(4) Fluid management requires considerable experience for successful drilling and sampling. Important fluid parameters include viscosity and density, and these parameters can be tested to improve fluid properties. Test Method D 4380 and American Petroleum Institute (API) test procedures are available for testing drill fluids. Fluid design can be improved by consultation with manufacturers, suppliers, and by review of literature (2-8). Because of a large number of suppliers, varying grades of drill fluid products, and varying requirements of each project, providing an exact procedure for design and mixing of drill fluids, is impossible.

#### 6.3.5 Rotary Drilling Using Air As the Circulation Medium:

6.3.5.1 The air compressor should provide an adequate volume of air, without significant contamination, for removal of cuttings. Air requirements depend upon the drill rod and bit type, character of the material penetrated, depth of drilling below ground water level, and total depth of drilling. Airflow rate requirements are usually based on an annulus upflow (or outflow) air velocity of about 3000 to 4000 ft/min (1000 to 1300 m/min) although air upflow (or outflow) rates of less than 3000 ft/min (1000 m/min) are often adequate for cuttings transport. Special reaming shells may be required to maintain air circulation between the annulus of the hole wall and large diameter drill rods (9). For some geologic conditions, air-blast erosion may increase the borehole diameter in easily eroded materials such that the 1000 m/min (3000 ft/min) circulation rate may not be appropriate for cuttings transport.

6.3.5.2 Compressed air alone often can transport cuttings from the borehole and cool the bit. Pure air alone does not work well in very moist soils. In moist, clayey matrices, mud rings and bit balling may occur. For some geologic conditions, water injected into the air stream will help control dust or break down “mud rings” that can form on the drill rods. If water is injected, the depth(s) of water injection should be documented. In these cases, adding water and a foaming agent to make a misting mixture is desirable (3). Under other circumstances, for example if the borehole starts to produce water, injection of a foaming agent may be required. The depth at which a foaming agent is added should also be recorded. If water infiltration into the borehole impedes circulation, the use of stiffer foams or slurries may be needed (3). Air drilling may not be satisfactory in unconsolidated or cohesionless soils under the ground water table, and fluid drilling systems may be required.

6.3.5.3 The dust collector conducts air and cuttings from the borehole annulus past the drill rod column to an air cleaning device (cyclone separator).

6.3.5.4 The air cleaning device (cyclone separator) separates cuttings from the air returning from the borehole via the dust collector. A properly sized cyclone separator can remove practically all of the cuttings from the return air. A small quantity of fine particles is usually discharged to the atmosphere with the “cleaned” air. Some air cleaning devices consist of a cyclone separator alone and others use a cyclone separator combined with a power blower and sample collection filters. When foaming agents are used, a cyclone-type cuttings separator is not used and foam discharge is accumulated near the top of the borehole.

6.4 Hole Diameters— Selection of hole diameter and core size is the most important consideration when planning a coring program. Most rock coring operations are performed with casings and core barrels whose sizes have been standardized by the Diamond Core Drill Manufacturers Association (DCDMA) (5,10). Table 1 provides a summary of nomenclature used for drill hole sizing. For each size of hole, there is a family of casings, core barrels, bits, casing bits, and drill rods with the same primary letter symbol (A through Z) whose design is compatible. Furthermore, the size steps are such that the next smaller size letter equipment can be used inside the next larger group. This nesting of casings, barrels, and rods allows for tapering or telescoping of a drill hole through difficult formations. Since the core barrel must pass through the casings selected, anticipating the necessity for telescoping the hole is important so a large enough diameter is selected at the start.

NOTE 2—Inclusion of the following tables and use of letter symbols in the foregoing text is not intended to limit the practice to use of DCDMA tools. The table and the text references are included as a convenience to the user since the majority of tools in use do meet the DCDMA dimensional standards. Similar equipment of approximately equal size on the metric standard system is acceptable unless otherwise stipulated by the engineer or geologist.

6.4.1 Core diameter, barrel design, bit design, and drilling method have a direct influence on sample quality. Usually when drilling in delicate formations, larger diameter samples provide higher quality samples. Often, obtaining samples of the weaker seams or joints in the rock is critical to design. A larger diameter core barrel can often reduce shearing stresses imparted to a seam

**TABLE 1 Diamond Core Drill Manufacturers Association Casing Specifications (10)**

NOTE 1—W series casing is known as “flush-coupled casing”. W series casing has flush inside diameter throughout, while X series casing has upset diameter with coupling inside diameter equal to flush wall inside diameter.

DCDMA Casing Design										
Size	Outside Diameter		Inside Diameter W Series		Inside Diameter X Series		Gallons Per 100 ft	Mass Per ft	Threads Per Inch	
	in.	mm	in.	mm	in.	mm			W series	X series
RW, RX	1.44	36.5	1.20	30.5	1.20	302.0	5.7	1.8	5	8
EW, EX	1.81	46.0	1.50	38.1	1.63	41.3	9.2	2.8	4	8
AW, AX	2.25	57.2	1.91	48.1	2.00	50.8	14.8	3.8	4	8
BW, BX	2.88	73.0	2.38	60.3	2.56	65.1	23.9	7.0	4	8
NW, NX	3.50	88.9	3.00	76.2	3.19	81.0	36.7	8.6	4	8
HW, HX	4.50	114.3	4.00	100.0	4.13	104.8	65.3	11.3	4	5
PW, PX	5.50	139.7	5.00	127.0	5.13	130.2		14.0	3	5
SW, SX	6.63	168.3	6.00	152.4	6.25	158.8		16.0	3	5
UW, UX	7.63	193.7	7.00	177.8	7.19	182.6			2	4
ZW, ZX	8.63	219.1	8.00	203.2	8.19	208.0			2	4

or joint in the core and thus reduce mechanical breakage. For core operations related to most surface drilling project investigations, the minimum core size would correspond to “N” sized borings.

6.4.2 In concrete coring operations, the primary consideration for selecting a core diameter is the maximum size aggregate. For interface shear strength determinations on lift lines, the core diameter should be 2½ to 3 times the maximum size aggregate (11).

6.4.3 In underground hard rock drilling, smaller cores may be used for ease of operation.

6.5 *Casing*—For most coring operations, setting casings in overburden materials will be necessary, especially near the surface to control drill fluid circulation. Typically, water-sensitive soils and loose overburden soils are protected by casings that are set in competent bedrock or to firm seating at an elevation below the water-sensitive formation. The casing used should allow for unobstructed passage of the largest core barrel to be used, and should be free of upsets in inside diameter. A listing of DCDMA casing sizes is shown in Table 1. For rock coring operations, the flush inside diameter “W” series casing is used to allow for use of the matching core barrel. In some cases, flush coupled drive pipe can be used to support the hole. Drive pipe is available in thickness schedules 40, 80, and 160.

6.5.1 Casing and drill rod selection should be based on uphole (or outflow) velocity of the circulation system selected. Uphole (or outflow) velocity should be sufficient to bring up all drill cuttings.

6.5.2 Casing or temporary drill hole support can be accomplished through several methods. One casing advancement technique is to drill incrementally ahead of the casing and then drive the casing to the previous depth. Driven casings should be equipped with a hardened shoe to protect end threads. The inside diameter of the shoe should be flush with the casing inside diameter to avoid hang-ups of the core barrel. In some cases, water-sensitive zones may require cementing for stabilization. Casing can be equipped with diamond casing shoes that allow the casing to be advanced with rotary drilling. The casing shoe should have the same inside diameter as the casing. Casing “shoes” should not be confused with casing “bits” (10). Casing bits are only acceptable for temporary, rotary installation of casing where coring operations are not required, such as temporary installation of a large diameter telescoped casing. Casing “bits” have an inside diameter that is not large enough to pass a core barrel of the same nominal hole size. Hollowstem augers may be used as casing through overburden soils. Liners may be used inside large diameter casings or augers to increase fluid circulation velocity and optimize cuttings return. If liners are used, they should not be driven and care should be taken to maintain true hole alignment.

6.6 *Drill Rods*—Drill rod selection should be based on consideration of the uphole (or outflow) velocity of the circulating fluids for the circulation system selected. Uphole velocity should be sufficient to bring up all drill cuttings. Most drilling operations are done with DCDMA drilling rods conforming to the dimensions given in Table 2. Drill rods are normally constructed of tubular steel and have a flush outside wall diameter. Drill rod sections usually have threaded female connections machined in each end. The rods are connected by either removable or welded pins (in one end) strengthened by addition of material at the inside walls. Some drill rod pins are constructed of high strength steel because the joints are a weak link and are subject to failure. Some larger rods are composed of composite materials to reduce weight. Nonmagnetic rods are available for drill holes requiring use of magnetic surveying equipment.

6.6.1 Tables 3 and 4 lists dimensions of wireline and API drill rods that also can be used. Wireline drill rod dimensions are not standardized and are specific to individual manufacturers. The API internal flush joint rods have upset walls on the outside joint and should not be used in air drilling, as air erosion of the formation could occur at the joints.

6.7 *Conventional Core Barrels*—Many types of core barrels are available. A conventional core barrel is attached to the drilling rods (see 6.6) and the complete set of connected rods and barrel must be removed from the hole at the end of each core run. Torque is applied to the drill rods while the circulating fluid is pumped through the center of the drill rods to the bit. Fluid returns along the annulus between the borehole wall and barrel and drill rods. Conventional barrels are used in smaller drilling operations, such as short underground holes, or when intermittent sampling is to be performed. Most continuous high production coring today is performed with wireline equipment.

**TABLE 2 Diamond Core Drill Manufacturers Association Drill Rod Specifications (10)**

Drill Rods, W Series Drill Rod									
Rod Type	Outside Diameter		Inside Diameter		Coupling Identification		Mass Per Foot, lbm	Threads Per Inch	Thread Type
	in.	mm	in.	mm	in.	mm			
RW	1.094	27.8	0.719	18.3	0.406	10.3	1.4	4	Regular
EW	1.375	34.9	0.938	22.2	0.437	12.7	2.7	3	Regular
AW	1.750	44.4	1.250	31.0	0.625	15.9	4.2	3	Regular
BW	2.125	54.0	1.500	44.5	0.750	19.0	6.1	3	Regular
NW	2.625	66.7	2.000	57.4	1.38	34.9	7.8	3	Regular
HW	3.500	88.9	3.062	77.8	2.375	60.3	9.5	3	Regular
WJ Series Drill Rod									
AWJ	1.75	44.5	1.43	36.4	0.63	16.1	3.6	5	Taper
BWJ	2.13	54.0	1.81	46.0	0.75	19.3	5.0	5	Taper
NWJ	2.63	66.7	2.25	57.0	1.13	28.8	6.0	4	Taper
KWJ	2.88	73.0	2.44	61.9	1.38	34.9	...	4	Taper
HWJ	3.50	88.9	2.88	73.1	1.75	44.5	...	4	Taper
Old Standard									
E	1.313	33.3	0.844	21.4	0.438	11.1	...	3	Regular
A	1.625	41.3	1.266	28.6	0.563	14.3	...	3	Regular
B	1.906	48.4	1.406	35.7	0.625	15.9	...	5	Regular
N	2.375	60.3	2.000	50.8	1.000	25.4	...	4	Regular

**TABLE 3 Wireline Drill Rod Dimensions**

Wireline Drill Rods								
Rod Type	Outside Diameter		Inside Diameter		Gallons Per 100 ft	Weight Per lbm	Threads Per Inch	Thread Type
	in.	mm	in.	mm				
AQWL <sup>A</sup>	1.750	44.5	1.375	34.9	7.7	3.3	4	Taper
AXWL <sup>B</sup>	1.813	46.0	1.500	38.1	9.18	2.8	4	Regular
BQWL <sup>A</sup>	2.188	55.6	1.812	46.0	13.4	4.0	3	Taper
BXWL <sup>B</sup>	2.250	57.2	1.906	48.4	14.82	3.8	4	Regular
NQWL <sup>A</sup>	2.750	69.9	2.375	60.3	23.0	5.2	3	Taper
NXWL <sup>B</sup>	2.875	73.0	2.391	60.7	23.30	6.8	3	Regular
HQWL <sup>A</sup>	3.500	88.9	3.062	77.8	38.2	7.7	3	Taper
HXWL <sup>B</sup>	3.500	88.9	3.000	76.2	36.72	8.7	3	Regular
PQWL <sup>A</sup>	4.625	117.5	4.062	103.2	...	...	...	...
CPWL <sup>B</sup>	4.625	117.5	4.000	101.6	...	...	...	...

<sup>A</sup>Q Series rods are specific manufacturer's design.

<sup>B</sup>X Series rods are specific manufacturer's design.

**TABLE 4 American Petroleum Institute Drill Rod Dimensions (12)**

API Tool Joints—Regular External Flush (in.-lb System)				
Type/size	Rod o.d. (in.)	Rod o.d. (mm)	Rod i.d. (in.)	Rod i.d. (mm)
API 2-3/8	3.125	79.4	1	25.4
API 2-7/8	3.75	95.3	1.25	31.8
API 3-1/2	4.25	108.0	1.5	38.1
API 4	5.25	133.4	1.75	44.5
API 4-1/2	5.75	146.1	2.25	57.2
API 5 1/2	6.75	171.5	2.75	69.9
API 6 5/8	7.75	196.9	3.5	88.9
API 7 5/8	8.88	225.6	4.0	101.6
API 8 5/8	10.0	25.4	4.75	120.7
API Tool Joints—Regular Internal Flush				
Type/size	Rod o.d. (in.)	Rod o.d. (mm)	Rod i.d. (in.)	Rod i.d. (mm)
API 2-3/8	3.375	85.7	1.75	44.5
API 2-7/8	4.125	104.8	2.125	54.0
API 3-1/2	4.75	120.7	2.687	68.3
API 4	5.75	146.1	3.25	82.6
API 4-1/2	6.125	155.6	3.75	95.3

6.7.1 Several series of conventional core barrels have standardized dimensions set by the DCDMA (10) in North America. Other organizations such as the British Standards Institute have adopted DCDMA size conventions, while others have different standard dimensions such as metric or Swedish (Craelius) (4). The DCDMA WG, WM, WT series of barrels have standard dimensions as shown in Table 5. Most manufacturers make core barrels fitting the dimensional requirements of one of these series, but there may

**TABLE 5 Approximated Core and Hole Diameters for Core Barrels**

<sup>A</sup> Core barrel type/group	Set bit dimension inside diameter = core diameter		Set reaming shell = hole diameter	
	in.	mm	in.	mm
Conventional Core Barrels <sup>B</sup>				
RWT (d)	0.735	18.7	1.175	29.8
EWD <sub>3</sub>	0.835	21.2	1.485	37.7
EWG (s.d.), EWM (d)	0.845	21.5	1.485	37.7
EWT (d)	0.905	23.0	1.485	37.7
AWD <sub>3</sub> , AWD <sub>4</sub>	1.136	28.9	1.890	48.0
AWG (s.d.), AWM (d)	1.185	30.1	1.890	48.0
AWT (d)	1.281	32.5	1.890	48.0
BWD <sub>3</sub> , BWD <sub>4</sub>	1.615	41.0	2.360	59.9
BWG (s.d.), BWM (d)	1.655	42.0	2.360	59.9
BWT (s.d.)	1.750	44.4	2.360	59.9
NWD <sub>3</sub> , NWD <sub>4</sub>	2.060	52.3	2.980	75.7
NWG (s.d.), NWM (d)	2.155	54.7	2.980	75.7
NWT (s.d.)	2.313	58.8	2.980	75.7
HWD <sub>3</sub> , HWD <sub>4</sub>	2.400	61.1	3.650	92.7
HWG (s.d.)	3.000	76.2	3.907	99.2
HWT (s.d.)	3.187	80.9	3.907	99.2
DCDMA Large Diameter—Double-Tube Swivel—Core Barrels				
2¾ × 3⅞	2.690	68.3	3.875	98.4
4 × 5½	3.970	100.8	5.495	139.3
6 × 7¾	5.970	151.6	7.750	196.8
Wireline Core Barrel Systems <sup>C</sup>				
AXWL (joy)	1.016	25.8	1.859	47.2
AQWL	1.065	27.1	1.890	48.0
BXWL	1.437	36.5	2.375	60.3
BQWL	1.432	36.4	2.360	60.0
BQ <sub>3</sub> WL	1.313	33.4	2.360	60.0
NXWL	2.000	50.8	2.984	75.8
NQWL	1.875	47.6	2.980	75.7
NQ <sub>3</sub> WL	1.75	44.4	2.980	75.7
HXWL	2.400	61.0	3.650	92.7
HQWL	2.500	63.5	3.790	96.3
HQ <sub>3</sub> WL	2.375	60.3	3.790	96.3
CPWL	3.345	85.0	4.827	122.6
PQWL	3.345	85.0	4.827	122.6
PQ <sub>3</sub> WL	3.25	82.6	4.827	122.6

<sup>A</sup>s = single tube; d = double tube.

<sup>B</sup>Conventional double-tube core barrels are available in either rigid or swivel designs. The swivel design inner barrel is preferred for sampling because it aids in preventing core rotation. In general, smallest core for given hole size results in best recovery in difficult conditions, that is, triple-tube core barrels. Use of double-tube-swivel type barrels with split liners is recommended in geotechnical investigations for best recovery and least sample damage.

<sup>C</sup>Wireline dimensions and designations may vary according to manufacturer.

be variation of other design features such as inner liners, bearings, fluid routing, or core extrusion methods. Some manufacturers make core barrels that do not fit dimensional DCDMA standards for core diameters. An example is the “D<sub>3</sub> and D<sub>4</sub>” series core barrels shown in Table 5. Use of other nonstandardized core barrels is acceptable if the type of barrel is appropriate for the drilling conditions and the type of barrel used is reported.

6.7.2 For most investigations and when rock types are unknown, it is desirable to specify a swivel type, double tube core barrel with a split inner barrel, or solid inner barrel with split liners (also know as “triple tube”). The barrel should be equivalent to, or better than, “M” series design to reduce fluid exposure. If the formation is poorly lithified, and contains soil-like layers such as shales with interbedded clay seams, a large diameter core barrel may be specified to aid in recovery. These desired components are discussed below.

6.7.3 Core barrels generally come in 5- or 10-ft core run lengths. Ten-foot core runs can be performed with good rock conditions. If soft, friable, or highly fractured formations are encountered, it may be necessary to select barrels with 5-ft core runs to reduce the possibility of blockages and improve core recovery.

6.7.4 Important design components of a conventional core barrel are tube type (triple, double, or single), inner tube rotation (rigid or swivel), core bit type, including fluid discharge locations (internal discharge - contacting core, or face discharge and waterway design), core lifter, and reaming shell.

6.7.5 *Single Tube Core Barrel*—The single tube core barrel is the simplest in design (see Fig. 2). The core is subjected to drill fluid circulation over its entire length. Once the core in the barrel is broken from parent material, it will rotate with the assembly.



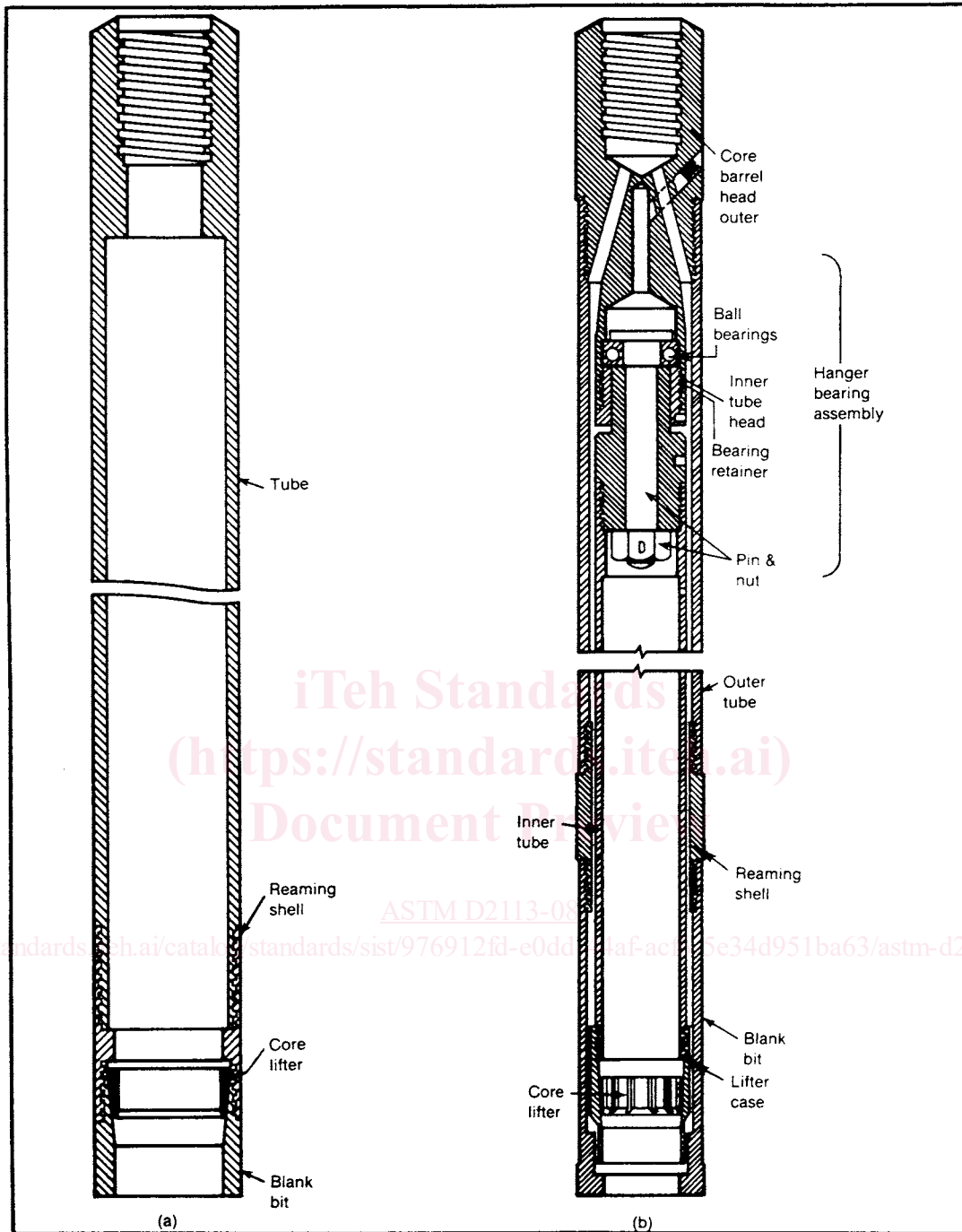

FIG. 2 Diagram of Two Types of Core Barrels: (a) Single Tube and (b) Double Tube

These effects break up all but the most competent core (4, 12). Because of fluid exposure and rotational effects, this barrel should not be used to sample weak, friable, and water-sensitive materials. Additional disadvantages of this core barrel include: poor diamond performance of the cutting bit in fractured or friable formations, frequent core blocking, and severe diamond erosion due to re-drilling of broken fragments. This system is only suitable for sampling massive, hard, competent, homogeneous rock or concrete. Due to these disadvantages, this core barrel type is not recommended for routine investigations.

6.7.5.1 In shallow applications, generally less than 5 ft (2 m) competent concrete or soil cement is cored with single tube masonry core barrels with portable drill rigs (11). If there is evidence of excessive core erosion, breakage, or blocking, use of double tube swivel type barrels should be considered.

6.7.6 *Double Tube Core Barrel*—Double tube core barrels contain an inner barrel that protects the core from contact with drill fluid and from erosion or washing from the circulating fluid. The bottom of the core may be subjected to fluid exposure depending on the locations of fluid discharge. Some barrel designs have fluid discharge near the lifter, near the bit, or on the bit face (see

6.7.7). The advantage of double tube design is greater protection of the core. Washing erosion is reduced and weaker zones can be recovered.

6.7.6.1 The inner barrel of double tube core barrels may be either solid or split. The barrel may be designed to accept split liners. Barrels accepting liners require a special inside diameter bit gauge. Use of a split barrel or inner liners is preferred for easier handling of cores. Sections of the cores containing weak seams are more likely to remain intact. The cores may be rolled onto PVC half rounds. The use of split liners or PVC half rounds aids in placement of core in core boxes and handling of cores that require sealing for moisture preservation. In certain materials, such as expansive shales or blocked high fractured materials, the split liner may spring apart even though it is taped before sampling. In these cases, removing the inner barrel may be difficult. Remedies include use of a shorter core barrel, triple tube design with extruder (see 6.7.7.1), or the solid liner.

6.7.6.2 Double tube core barrels come in two designs, either rigid or swivel type.

(1) *Rigid Double Tube Barrel*—This barrel is rarely used in practice today due to limitations listed below. In the rigid barrel design, the inner barrel is fixed and it spins at the same rate as the outer barrel. Rigid tube barrels have fewer working parts, but suffer from similar disadvantages as single tube barrels. Core recovery is poor and diamond wear in friable and fractured formations is excessive. In softer deposits, there will be rotation of broken core, core blockage, and resulting crushing and grinding, which causes excessive bit wear. This type of design is not preferred for routine investigations where rock conditions are not known, as the equipment is only acceptable in hard competent formations.

(2) *Swivel Type Double Tube Barrels*—In the swivel type barrel (Fig. 3 and Fig. 4 show typical barrels) the inner barrel is connected to the drill string through a bearing that allows the inner barrel to remain stationary during coring. The core is completely protected once it enters the liner. This design reduces rock crushing and grinding and resulting blockages. Depending on the fluid discharge point, the core may be exposed to fluids near the bottom of the barrel and there could be erosion of soft or fractured formations.

(3) Double tube swivel type core barrels are the best selection for drilling rock of varying hardness and fracture. This type of barrel is typically the minimum requirement when drilling investigations are for engineering structures where varying conditions would be encountered.

6.7.7 *Triple Tube Core Barrels*—The triple tube barrel is essentially a double tube barrel with a liner inside the inner tube. The inner liner is made from either split metal half rounds or tubular acrylic. The use of split liners increases efficiency in handling and logging. If the purpose of the investigation is solely for logging of cores, the use of solid acrylic liners may be acceptable.

6.7.7.1 Many manufacturers offer the triple tube option and barrels are available that also have hydraulic core extrusion systems. These systems help with removing the inner liners by use of a piston in the top of the inner barrel. This feature is especially helpful if split liners are bowed apart by lateral expansion of the core. The extrusion systems allow for simple loading and unloading of liners.

6.7.8 *Conventional Barrel Standardized Designs*—DCDMA standardized barrels come in three designs, WG, WM, and WT series.

6.7.8.1 The “G” series barrels are the most simple in design and have a simple pin threaded bit into which the core lifter is inserted. Due to the simplicity of design, these barrels are the most rugged, with fewer parts and less maintenance. The only disadvantage is that the fluid exits above the lifter and the bottom of the core is exposed to fluids during drilling.

6.7.8.2 The “M” design core barrel is the best available tool for recovering of rock cores even in the most friable and caving stratus. The inner barrel is equipped with a lifter case that extends into the bit shank and therefore reduces exposure of the core to fluid during drilling. The fluid only contacts the core near the crown of the bit, and washing or eroding of the core is minimized. Face discharge bits are also available for almost no core exposure to fluids. The DCDMA “M” designs have been modified by individual manufacturers. Barrels such as the D<sub>4</sub> type barrels are equivalent to “M” design barrels.

6.7.8.3 The “T” series design stands for thin walled or thin kerf. This design provides larger core-to-hole size ratio. This barrel style has a thin kerf and requires fewer diamonds and less torque for drilling. It gives good performance in hard, dense, and friable shattered rock formations (4). This type of core barrel is thin and lightweight and must be handled with care.

6.7.9 *Large Diameter, Double Tube, Swivel Design*—The large diameter conventional core barrel is similar in design to the double tube, swivel type, “WM” design, but with the addition of a ball valve in all the three sizes to control fluid flow. A sludge barrel to catch heavy cuttings is also incorporated on the two larger sizes (Fig. 5). The three sizes standardized by DCDMA are 2¾-in. (69.8 mm) by 3⅞-in. (98.4 mm), 4-in. (101.6 mm) by 5½-in. (139.7 mm), and 6-in. (152.4 mm) by 7¾-in. (196.8 mm). Other sizes such as 4⅝-in. (117.5 mm) by 3-in. (76.2 mm), 5¾-in. (146 mm) by 4-in. (101.6 mm), and 8-in. (203.2 mm) by 5⅞-in. (149.2 mm) have been designed by individual manufacturers. The larger barrels with increased annulus are suitable for larger rotary rig mud pumps and air compressors. Options include either conventional or face discharge bits with either conventional core lifter or spring finger basket retainers. Some core barrel systems can be converted to soil coring operations, but require carbide bit and a projecting cutting shoe. Some large diameter barrels are convertible from conventional to wireline coring operation.

6.8 *Wireline Core Barrels*—Wireline drilling for investigation in rock is a principal drilling system used for deep rock coring applications using surface mounted drill rigs (Fig. 6 and Fig. 7). In the wireline system, the drill rods are only removed from the hole to replace the coring bit, to free a stuck inner barrel, or to adjust the headspace of the inner barrel. The inner core barrel can be removed and replaced without removing the drill rods, allowing for continuous coring. The drill rods also act as a casing, and fluid is circulated from the bit through the annulus between the drill hole wall and drill rod. Wireline drill rod dimensions are not