



SLOVENSKI STANDARD

SIST ISO 8528-9:2018

01-julij-2018

Nadomešča:
SIST ISO 8528-9:2002

Agregati za proizvodnjo izmeničnega toka, gnani z batnim motorjem z notranjim zgorevanjem - 9. del: Merjenje in vrednotenje mehanskih vibracij

Reciprocating internal combustion engine driven alternating current generating sets -- Part 9: Measurement and evaluation of mechanical vibrations

iTeh STANDARD PREVIEW
(standards.iteh.ai)

Groupes électrogènes à courant alternatif entraînés par moteurs alternatifs à combustion interne -- Partie 9: Mesurage et évaluation des vibrations mécaniques

<https://standards.iteh.ai/catalog/standards/sist/53904f1b-aefd-4eb3-bd4b-f3caefa78953/sist-iso-8528-9-2018>

Ta slovenski standard je istoveten z: ISO 8528-9:2017

ICS:

17.160	Vibracije, meritve udarcev in vibracij	Vibrations, shock and vibration measurements
27.020	Motorji z notranjim zgorevanjem	Internal combustion engines
29.160.40	Električni agregati	Generating sets

SIST ISO 8528-9:2018

en,fr

iTeh STANDARD PREVIEW
(standards.iteh.ai)

[SIST ISO 8528-9:2018](#)

<https://standards.iteh.ai/catalog/standards/sist/53904f1b-aefd-4eb3-bd4b-f3caefa78953/sist-iso-8528-9-2018>

INTERNATIONAL
STANDARD

ISO
8528-9

Second edition
2017-07

**Reciprocating internal combustion
engine driven alternating current
generating sets —**

**Part 9:
Measurement and evaluation of
mechanical vibrations**

iTeh STANDARD PREVIEW
(standards.iteh.ai)

*Groupes électrogènes à courant alternatif entraînés par moteurs
alternatifs à combustion interne —*

Partie 9: Mesurage et évaluation des vibrations mécaniques

<https://standards.iteh.ai/catalog/standards/sist/53904f1b-aefd-4eb3-bd4b-f3caefa78953/sist-iso-8528-9-2018>



Reference number
ISO 8528-9:2017(E)

© ISO 2017

iTeh STANDARD PREVIEW
(standards.iteh.ai)

SIST ISO 8528-9:2018

<https://standards.iteh.ai/catalog/standards/sist/53904f1b-aefd-4eb3-bd4b-f3caefa78953/sist-iso-8528-9-2018>



COPYRIGHT PROTECTED DOCUMENT

© ISO 2017, Published in Switzerland

All rights reserved. Unless otherwise specified, no part of this publication may be reproduced or utilized otherwise in any form or by any means, electronic or mechanical, including photocopying, or posting on the internet or an intranet, without prior written permission. Permission can be requested from either ISO at the address below or ISO's member body in the country of the requester.

ISO copyright office
Ch. de Blandonnet 8 • CP 401
CH-1214 Vernier, Geneva, Switzerland
Tel. +41 22 749 01 11
Fax +41 22 749 09 47
copyright@iso.org
www.iso.org

Contents

Page

Foreword.....	iv
1 Scope.....	1
2 Normative references.....	1
3 Terms and definitions.....	1
4 Symbols and abbreviated terms.....	1
5 Regulations and additional requirements.....	2
6 Measuring devices.....	2
7 Location of measuring points and direction of measurements.....	3
8 Operating conditions during measurement.....	3
9 Evaluation of results.....	3
10 Test report.....	4
Annex A (informative) Typical generating set configurations.....	5
Annex B (informative) Remarks on the assessment of vibrations of the generating set.....	8
Annex C (informative) Vibration values.....	9
Annex D (informative) Measuring report.....	10
Bibliography.....	12

iteh STANDARD PREVIEW
(standards.iteh.ai)

SIST ISO 8528-9:2018

<https://standards.iteh.ai/catalog/standards/sist/53904f1b-aefd-4eb3-bd4b-f3caefa78953/sist-iso-8528-9-2018>

ISO 8528-9:2017(E)

Foreword

ISO (the International Organization for Standardization) is a worldwide federation of national standards bodies (ISO member bodies). The work of preparing International Standards is normally carried out through ISO technical committees. Each member body interested in a subject for which a technical committee has been established has the right to be represented on that committee. International organizations, governmental and non-governmental, in liaison with ISO, also take part in the work. ISO collaborates closely with the International Electrotechnical Commission (IEC) on all matters of electrotechnical standardization.

The procedures used to develop this document and those intended for its further maintenance are described in the ISO/IEC Directives, Part 1. In particular the different approval criteria needed for the different types of ISO documents should be noted. This document was drafted in accordance with the editorial rules of the ISO/IEC Directives, Part 2 (see www.iso.org/directives).

Attention is drawn to the possibility that some of the elements of this document may be the subject of patent rights. ISO shall not be held responsible for identifying any or all such patent rights. Details of any patent rights identified during the development of the document will be in the Introduction and/or on the ISO list of patent declarations received (see www.iso.org/patents).

Any trade name used in this document is information given for the convenience of users and does not constitute an endorsement.

For an explanation on the voluntary nature of standards, the meaning of ISO specific terms and expressions related to conformity assessment, as well as information about ISO's adherence to the World Trade Organization (WTO) principles in the Technical Barriers to Trade (TBT) see the following URL: www.iso.org/iso/foreword.html. (standards.iteh.ai)

This document was prepared by ISO/TC 70, *Internal combustion engines*.

This second edition cancels and replaces the first edition (ISO 8528-9:1995), which has been technically revised.

A list of all parts in the ISO 8528 series can be found on the ISO website

Reciprocating internal combustion engine driven alternating current generating sets —

Part 9: Measurement and evaluation of mechanical vibrations

1 Scope

This document describes a procedure for measuring and evaluating the external mechanical vibration behaviour of generating sets at the measuring points stated in this document.

It applies to RIC engine driven a.c. generating sets for fixed and mobile installations with rigid and/or resilient mountings. It is applicable for land and marine use, excluding generating sets used on aircraft or those used to propel land vehicles and locomotives.

For some specific applications (essential hospital supplies, high rise buildings, etc.) supplementary requirements may be necessary. The provisions of this document are intended to be regarded as a basis for such applications.

For generating sets driven by other reciprocating-type prime movers (e.g. sewage gas engines, steam engines), the provisions of this document are intended to be regarded as a basis for such applications.

2 Normative references

SIST ISO 8528-9:2018

The following documents are referred to in the text in such a way that some or all of their content constitutes requirements of this document. For dated references, only the edition cited applies. For undated references, the latest edition of the referenced document (including any amendments) applies.

ISO 2041, *Mechanical vibration, shock and condition monitoring — Vocabulary*

ISO 8528-5:2013, *Reciprocating internal combustion engine driven alternating current generating sets — Part 5: Generating sets*

3 Terms and definitions

For the purposes of this document, the terms and definitions given in ISO 2041 and the following apply.

ISO and IEC maintain terminological databases for use in standardization at the following addresses:

— IEC Electropedia: available at <http://www.electropedia.org/>

— ISO Online browsing platform: available at <http://www.iso.org/obp>

3.1

vibration severity

generic term that designates a value or set of values, such as a maximum value, average value or rms value, or other parameter that is descriptive of the vibration

Note 1 to entry: It may refer to instantaneous values or average values.

4 Symbols and abbreviated terms

For the purposes of this document the following symbols apply.

ISO 8528-9:2017(E)

n_r	Declared engine speed
f	Frequency
s	Displacement
t	Time
v	Velocity
w	Angular velocity
x	Axial co-ordinate
y	Transverse co-ordinate
z	Vertical co-ordinate

The following subscripts are used in conjunction with the vibration quantities v and s .

rms	Value of vibration quantity
x	Measured value of vibration quantity in the axial direction
y	Measured value of vibration quantity in the transverse direction
z	Measured value of vibration quantity in the vertical direction
1, 2 ... n	Progressive values

STANDARD PREVIEW
(standards.iteh.ai)

5 Regulations and additional requirements

5.1 For a.c. generating sets used on board ships and offshore installations which are required to comply with rules of a classification society, the additional requirements of the classification society shall be observed. The classification society shall be stated by the customer prior to placing the order.

For a.c. generating sets in unclassified equipment, such additional requirements are in each case subject to agreement between the manufacturer and customer.

5.2 If special requirements from regulations of any other authority, e.g. inspecting and/or legislative authorities, are required to be met, the authority shall be stated by the customer prior to placing the order.

Any further additional requirements shall be subject to agreement between the manufacturer and customer prior to placing the order.

6 Measuring devices

The measuring system shall provide the rms values of displacement and velocity with an accuracy of $\pm 10\%$ over the range 10 Hz to 1 000 Hz and an accuracy of $-20\%/+10\%$ over the range 2 Hz to 10 Hz. These values may be obtained from a single sensor whose signal is either integrated or differentiated, depending on the outcome of the measuring device, to derive the quantities not directly measured, provided the accuracy of the measuring system is not adversely affected.

The accuracy of measurement is also affected by the method of connection between the transducer and the object being measured. Both the frequency response and the measured vibration are affected by the method of attaching the transducer. It is especially important to maintain good attachment between the transducer and the point on the generating set being measured when vibration levels are high.

7 Location of measuring points and direction of measurements

[Figure 1](#) shows the recommended points of vibration measurement in generating sets. The specifications apply as appropriate for other types of design. If possible, measurements shall be taken at these points in the three main directions, defined by x, y and z.

[Figure 1](#) shows the approximate positions of the measuring points which have to be located on the solid engine block and on solid areas of the generator main body in order to avoid measuring local structural vibrations.

If experience with similar sets has shown at which points the maximum vibration severity is to be expected, not all the points given in [Figure 1](#) need necessarily be measured.

The vertical in-line engine shown is given as an example only. Measuring points 1 to 4 are applicable as appropriate for other types of engine, e.g. V-engines, horizontal engines.

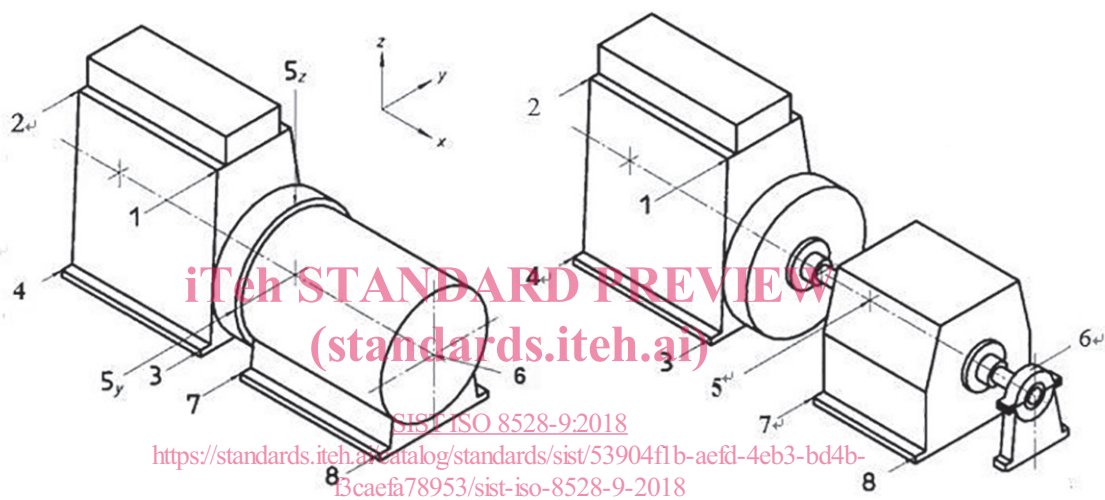

a) Generating set driven by a vertical in-line engine with flange housing coupled generator with integral bearings

b) Generating set driven by a vertical in-line engine and a generator with pedestal bearings

Key

- 1, 2 front end top edge and back end top edge
- 3, 4 front and rear lower edge of engine cylinder block
- 5, 6 generator main bearing housing (5 may also be the flange housing for single bearing machines)
- 7, 8 generator (main body) mounting points

Figure 1 — Arrangement of measuring points

8 Operating conditions during measurement

The measurements shall be taken with the generating set *under steady state conditions* at its operating temperature and rated frequency at rated power. If the rated power of the generating set is not attainable, it should be tested at the maximum power that can be attained.

9 Evaluation of results

The main excitation frequencies of the RIC engine are found in the range 2 Hz to 300 Hz. However, when considering the overall generating set structure and components, a range of 2 Hz to 1 000 Hz is required to evaluate the vibration.