



Designation: ~~D1790-02~~ Designation: D 1790 - 08

Standard Test Method for Brittleness Temperature of Plastic Sheeting by Impact¹

This standard is issued under the fixed designation D 1790; the number immediately following the designation indicates the year of original adoption or, in the case of revision, the year of last revision. A number in parentheses indicates the year of last reappraisal. A superscript epsilon (ϵ) indicates an editorial change since the last revision or reappraisal.

This standard has been approved for use by agencies of the Department of Defense.

1. Scope*

1.1 This test method covers the determination of that temperature at which plastic sheeting 1.00 mm (0.040 in.) or less in thickness exhibits a brittle failure under specified impact conditions.

1.2 The values stated in SI units are to be regarded as the standard. The values given in parentheses are for information only.

NOTE 1—This test method was developed jointly with the Society of the Plastics Industry, primarily for use with plasticized vinyl sheetings. Its applicability to other plastic sheetings must be verified by the user.

1.3 *This standard does not purport to address the safety concerns, if any, associated with its use. It is the responsibility of the user of this standard to establish appropriate safety and health practices and determine the applicability of regulatory limitations prior to use. Specific precautionary statements are given in Note 4.*

NOTE 2—This test method is similar to ISO 8570-1991 in title only. The technical content is significantly different. 2—This test method and ISO 8570 address the same subject matter, but differ in technical content.

2. Referenced Documents

2.1 ASTM Standards:²

D 618 Practice for Conditioning Plastics for Testing

D 883 Terminology Relating to Plastics² Terminology Relating to Plastics

D 5947 Test Methods for Physical Dimensions of Solid Plastics Specimens

D 6988 Guide for Determination of Thickness of Plastic Film Test Specimens

E 691 Practice for Conducting an Interlaboratory Study to Determine the Precision of a Test Method

2.2 ISO Standard:

~~ISO 8570-1991~~ ISO 8570 Plastics—Film and Sheeting—Determination of Cold-Crack Temperature³

3. Terminology

3.1 Definitions:

3.1.1 *brittleness temperature, T_b* — that temperature, derived statistically, where 80 % of the specimens would probably pass 95 % of the time when a stated minimum number are tested by this test method. The 80 %-passing value ~~may be~~ determined by plotting the data on probability graph paper, as described in 9.1.

3.1.2 *General* —Definitions of terms applying to this test method appear in Terminology D 883.

4. Significance and Use

4.1 Data obtained by this test method ~~may have been~~ used to predict the behavior of plastic sheeting at low temperatures only if the conditions of deformation are similar to those specified in this test method. This test method is useful for specification testing and for comparative purposes, but does not necessarily ~~measure~~ determine the lowest use temperature at which the plastic sheeting ~~may be used for a particular plastic.~~

4.2 It has been demonstrated that on calendered sheeting the brittleness temperature is sensitive to the direction of fold. It has also been demonstrated that the brittleness temperature is sensitive to the direction of sampling. Therefore, it is imperative that the procedure for taking specimens and folding be followed explicitly.

¹ This test method is under the jurisdiction of ASTM Committee D20 on Plastics and is the direct responsibility of Subcommittee D20.30 on Thermal Properties. Current edition approved March 10, 2002. Published May 2002. Originally published as D1790-60 T. Last previous edition D1790-99.

Current edition approved Oct. 1, 2008. Published October 2008. Originally approved in 1960. Last previous edition approved in 2002 as D 1790 - 02.

² For referenced ASTM standards, visit the ASTM website, www.astm.org, or contact ASTM Customer Service at service@astm.org. For *Annual Book of ASTM Standards* Vol 08.01 volume information, refer to the standard's Document Summary page on the ASTM website.

³ *Annual Book of ASTM Standards*, Vol 14.02.

³ Available from American National Standards Institute (ANSI), 25 W. 43rd St., 4th Floor, New York, NY 10036, <http://www.ansi.org>.

*A Summary of Changes section appears at the end of this standard.

5. Apparatus

5.1 *Cold Conditioning Chamber*, at least 450 by 450 by 450 mm (18 by 18 by 18 in.). Means (automatic or manual) shall be provided for controlling the temperature of the chamber to within $\pm 2^{\circ}\text{C}$ of the desired value.

5.2 *Impact Tester* shown in Fig. 1 shall be constructed of cold-rolled steel except for the bolts, screws, and rubber stopper. It is recommended that all structural parts (that is, base, anvil, arm, arm supports, and shaft) may be chromium plated to prevent corrosion. The arm, including the rubber stopper and bolt, shall weigh $3.09\text{ kg} \pm 28\text{ g}$ ($6\text{ lb } 13 \pm 1\text{ oz}$).

5.3 *Die*, $50.8 \pm 0.4\text{ mm}$ by $146.1 \pm 0.4\text{ mm}$ ($2 \pm \frac{1}{64}\text{ in.}$ by $5\frac{3}{4} \pm \frac{1}{64}\text{ in.}$) to cut the test specimens from the sample.

5.4 *Stapler*, desk-type, with a stop mounted on the base exactly 12.7 mm ($\frac{1}{2}\text{ in.}$) back of the center of the groove that turns the staple.

5.5 *Index Card Stock*, 50 by 127 mm (2 by 5 in.).

5.6 *Thickness Gauge*—A dead-weight dial or digital micrometer as described in D 5947 or D 6988 as appropriate for the material or specimen geometry being tested.

6. Test Specimens

6.1 The test specimens shall be cut with the die. The length of the test specimen shall be parallel to the transverse direction of the sheeting. The 50-mm (2-in.) ends of each specimen shall be so collected that a gradual, closed loop is formed at room temperatures. The collected ends of the specimen and one end of the 50 by 127-mm (2 by 5-in.) card shall be matched exactly with the body of the loop lying on the card. Two staples shall be crimped through the matched ends of the specimen and card. These staples shall be 13 mm ($\frac{1}{2}\text{ Test Specimens}$)

6.1 The test specimens shall be cut with the die. The length of the test specimen shall be parallel to the transverse direction of the sheeting.

6.2 The test specimens shall be selected so that the thickness is uniform to within 10% of the thickness over the length of the specimen in the case of specimens 0.25 mm (0.010 in.) or less in thickness and to within 5 % in the case of specimens greater than 0.25 mm (0.010 in.) in thickness but do not exceed 1.00 mm (0.040 in.) in thickness.

6.3 The 50-mm (2-in.) ends of each specimen shall be so collected that a gradual, closed loop is formed at room temperatures. The collected ends of the specimen and one end of the 50 by 127-mm (2 by 5-in.) card shall be matched exactly with the body of the loop lying on the card. Two staples shall be crimped through the matched ends of the specimen and card. These staples shall be 13-mm ($\frac{1}{2}\text{ in.}$) from, and parallel to, the 50-mm (2-in.) end of the stack.

6.4 Since it has been demonstrated that this test is sensitive to the direction of fold on calendered sheeting, it is necessary to stipulate that all specimens be folded in the same direction. It is recommended that, for materials with no grain, the specimen be folded so that the surface last in contact with the roll shall be inside the loop following the inherent shape of the specimen; grained materials are to be tested with the grained surface on the inside of the loop.

7. Conditioning

7.1 *Conditioning*—Condition the test specimens at $23 \pm 2^{\circ}\text{C}$ ($73.4 \pm 3.6^{\circ}\text{F}$) and $50 \pm 5\%$ relative humidity for not less than 40 h prior to test in accordance with Procedure A of Practice D 618, for those tests where conditioning is required. In cases of disagreement, the tolerances shall be $\pm 1^{\circ}\text{C}$ ($\pm 1.8^{\circ}\text{F}$) and $\pm 2\%$ relative humidity.

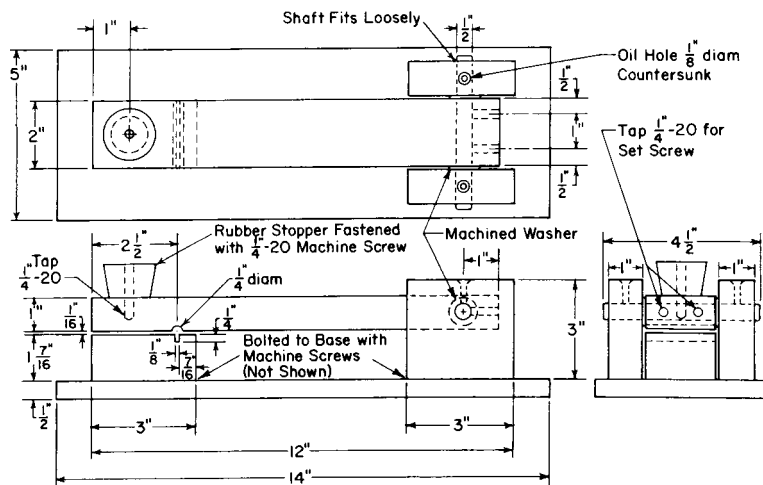

		Metric Equivalents									
in.	1/8	1/4	7/16	1/2	1	2 1/2	3	4 1/2	12	14	
mm	3.2	6.4	11.1	12.7	25.4	64	76	114	305	356	

FIG. 1 Brittleness Temperature Impact Testing Machine