



Designation: ~~F406-08~~ Designation: F 406 – 08a

Standard Consumer Safety Specification for Non-Full-Size Baby Cribs/Play Yards¹

This standard is issued under the fixed designation F 406; the number immediately following the designation indicates the year of original adoption or, in the case of revision, the year of last revision. A number in parentheses indicates the year of last reapproval. A superscript epsilon (ϵ) indicates an editorial change since the last revision or reapproval.

INTRODUCTION

This consumer safety specification addresses incidents associated with non-full-size cribs/play yards that were identified by the U.S. Consumer Product Safety Commission (CPSC).

Incidents identified by the CPSC and addressed in this standard include asphyxiation due to entrapment in mesh drop side units left with a side down, strangulation by entanglement on protruding hardware, strangulation by button entrapment in mesh openings, strangulation due to failure of the center hinge on a top rail, collapse or failure of the locking devices, collapse of the floor or sides, and choking on vinyl bitten from the top rail. This specification also addresses wooden non-full-size crib injuries or deaths due to entanglement on corner post extensions, dislodgment of slats resulting from breakage or failure of glue joints, collapse of mattress support, detachment of screws, dislodgment of teething rails, and entanglement on cords or strings.

This specification is not intended to cover non-full-size cribs/play yards that are either blatantly misused or abused. This specification is written within current state-of-the-art of non-full-size crib/play yard technology and is intended to be updated if substantive information becomes available that necessitates additional requirements or justifies revision of existing requirements.

1. Scope

1.1 This consumer safety specification establishes testing requirements for structural integrity and performance requirements for non-full-size cribs/play yards, both rigid sided and mesh/fabric assemblies. It also provides requirements for labeling and instructional material. The term unit or product will refer to a non-full-size crib/play yard.

1.2 This specification covers a framed enclosure with a floor made for the purpose of providing sleeping and playing accommodations for a child who cannot climb out and is less than 35 in. (890 mm) in height. It also covers bassinet, changing table, or similar attachments to a non-full size crib/play yard. These attachments shall also comply with the applicable requirements of ASTM standards addressing those attachments. For example, a changing table that attaches to a play yard shall also comply with the applicable requirements in Specification F 2388. This specification does not cover inflatable products.

1.3 No product produced after the approval date of this consumer safety specification shall, either by label or other means, indicate compliance with this specification unless it conforms to all applicable requirements contained herein, before and after all testing.

~~1.4 The values stated in inch-pound units are to be regarded as the standard. The SI units given in parentheses are for information only.~~

1.4 The values stated in inch-pound units are to be regarded as standard. The values given in parentheses are mathematical conversions to SI units that are provided for information only and are not considered standard.

1.5 The following safety hazards caveat pertains only to the test method portion, Section 8, of this specification: *This standard does not purport to address all of the safety concerns, if any, associated with its use. It is the responsibility of the user of this standard to establish appropriate safety and health practices and determine the applicability of regulatory limitations prior to use.*

NOTE 1—This consumer safety specification includes the following sections:

Title	Section
Scope	1
Referenced Documents	2
ASTM Standards	2.1

¹ This consumer safety specification is under the jurisdiction of ASTM Committee F15 on Consumer Products and is the direct responsibility of Subcommittee F15.18 on Cribs, Toddler Beds, Play Yards, Bassinets, Cradles and Changing Tables.

Current edition approved Feb. 15, Sept. 1, 2008. Published March/October 2008. Originally approved in 1977. Last previous edition approved in 2007/2008 as F 406 – 078.

Federal Regulations	2.4
Terminology	3
Definitions of Terms Specific to This Standard	3.1
Conspicuous	3.1.2
Cord	3.1.3
Corner Post	3.1.4
Dropside/Dropgate	3.1.5
Dynamic Load	3.1.6
Fabric	3.1.7
Foldable Side or End	3.1.8
Manufacturer's Recommended Use Position	3.1.9
Mattress	3.1.10
Mesh	3.1.11
Mesh/Fabric Crib	3.1.12
Nonpaper Label	3.1.13
Occupant	3.1.14
Paper Label	3.1.15
Protrusion	3.1.16
Rigid Sided Crib	3.1.17
Seam	3.1.18
Static Load	3.1.19
Stationary Side	3.1.20
Structural Failure	3.1.21
Structural Failure	<u>3.1.22</u>
Calibration and Standardization	4
General Requirements	5
Scissoring, Shearing, or Pinching	5.7
Latching and Locking Mechanisms	5.9
Openings	5.10
Protective Components	5.11
Labeling	5.12
Stability	5.13
Cord Length	5.14
Coil Springs	5.15
Mattress	5.17
Protrusions	5.18
Performance Requirements for Rigid Sided Units	6
Vertical Impact Testing	6.2
Mattress Support Testing	6.2.1
Side or End Testing, or Both	6.2.2
Mattress Support System Testing	6.3
Side(s) or End(s) Latch Testing, or Both	6.4
Dropside Latch Testing	6.4.1
Foldable Side or End Latch Testing	6.4.2
Plastic Teething Rail	6.5
Performance Requirements for Mesh/Fabric Units	7
Height of Sides	7.1
Side Deflection and Strength	7.2
Floor Strength	7.3
Top Rail Covering Material	7.4
Mesh Requirements	7.5
Mesh Openings	7.5.1
Mesh Strength	7.5.2
Fabric Material Requirements	7.6
Fabric Strength	7.6.1
Mesh/Fabric Assembly Requirements	7.7
Sewn Assembly	7.7.1
Seam Strength	7.7.2
Mesh/Fabric Attachment Strength	7.7.3
Test Methods	8
Mattress Support Impact Test for Rigid Sided Cribs	8.1
Side or End Impact Test, or Both, for Rigid Sided Cribs	8.2
Dropside Impact Test	8.2.2
Dropside Static Test	8.2.3
Stationary Side or Foldable Side Impact Test	8.2.4

iTeh Standards
 (https://standards.itih.ai)
 Document Preview

ASTM F406-08a

<https://standards.itih.ai/catalog/standards/sist/8b8328e8-3618-48e3-9f68-a3347db5e5c2/astm-f406-08a>

Stationary Side or Foldable Side Static Test	8.2.5
Mattress Support System Test for Rigid Sided Cribs	8.3
Side or End Latch Test, or Both, for Rigid Sided Cribs	8.4
Test Method for Dropline Latch	8.4.2
Procedure for Vertical Dropline Latch Tests	8.4.3
Procedure for Horizontally Hinged Dropline Latch Test	8.4.4
Test Procedure for Latches to Prevent Folding of a Foldable Side or End	8.4.5
Plastic Teething Rail Test for Rigid Sided Cribs	8.5
Procedure for Plastic Teething Rail Test	8.5.2
Side Deflection and Strength Tests for Mesh/Fabric Cribs	8.6
Floor Strength Test for Mesh/Fabric Cribs	8.7
Locking Mechanism Test	8.8
Dropline Locking Device Test Method	8.8.1
Folding Latch Test Method	8.8.2
Mesh Opening Test	8.9
Test for Strength of Mesh and Integrity of Attachment	8.10
Mesh/Fabric Attachment Strength Test Method	8.11
Test for Stability of Product	8.12
Permanency of Labels and Warnings	8.13
Removal of Protective Components	8.16
Torque Test	8.16.3
Tension Test	8.16.4
Vinyl Thickness Measurement	8.17
Test for Attachment of Storage Pouch or Other Parts with Printed Warnings	8.18
Cord Length Test Method	8.19
Protrusions	8.20
Marking and Labeling	9
Labeling	9.1
Warning Statements	9.2
Instructional Literature	10
Warning Statements	10.1.2
Water Mattress Use	10.3.3

iTech Standards
(<https://standards.itih.ai>)
Document Preview

ASTM F406-08a

2. Referenced Documents <https://standards.itih.ai/catalog/standards/sist/8b8328e8-3618-48e3-9f68-a3347db5e5c4/astm-f406-08a>

2.1 *ASTM Standards*:²

D 1424 Test Method for Tearing Strength of Fabrics by Falling-Pendulum Type (Elmendorf) Apparatus

D 1683 Test Method for Failure in Sewn Seams of Woven Apparel Fabrics

D 3359 Test Methods for Measuring Adhesion by Tape Test

D 5034 Test Method for Breaking Strength and Elongation of Textile Fabrics (Grab Test)

F 963 Consumer Safety Specification for Toy Safety

F 1487 Consumer Safety Performance Specification for Playground Equipment for Public Use

F 2388 Consumer Safety Specification for Baby Changing Tables for Domestic Use

2.2 *EN Standards*:³

EN 716–1:1995 Cots and Folding Cots for Domestic Use

EN 12227–1:1999 Playpens for Domestic Use

2.3 *ISO Standard*:⁴

ISO 8124-1:2000 Safety Aspects Related to Mechanical and Physical Properties

2.4 *Federal Regulations*:⁵

16 CFR 1303 Ban of Lead-Containing Paint and Certain Consumer Products Bearing Lead-Containing Paint

16 CFR 1500 Hazardous Substances Act Regulations including sections:

1500.3 (c) (6) (vi) Definition of “Flammable Solid”

² For referenced ASTM standards, visit the ASTM website, www.astm.org, or contact ASTM Customer Service at service@astm.org. For *Annual Book of ASTM Standards* volume information, refer to the standard’s Document Summary page on the ASTM website.

³ Available from American National Standards Institute (ANSI), 25 W. 43rd St., 4th Floor, New York, NY 10036.

⁴ Available from International Organization for Standardization (ISO), 1 rue de Varembeé, Case postale 56, CH-1211, Geneva 20, Switzerland.

⁵ Available from U.S. Government Printing Office Superintendent of Documents, 732 N. Capitol St., NW, Mail Stop: SDE, Washington, DC 20401.

- 1500.44 Method for Determining Extremely Flammable and Flammable Solids
 1500.48 Technical Requirements for Determining a Sharp Point In Toys and Other Articles Intended for Use By Children Under Eight Years of Age
 1500.49 Technical Requirements for Determining a Sharp Metal or Glass Edge in Toys or Other Articles Intended for Use By Children Under Eight Years of Age
 1500.50-.52 Test Methods for Simulating Use and Abuse of Toys and Other Articles Intended for Use By Children
 16 CFR 1501 Method for Identifying Toys and Other Articles Intended for Use By Children Under Three Years of Age Which Present Choking, Aspiration, or Ingestion Hazards Because of Small Parts
 16 CFR 1509 Requirements for Non-Full-Size Baby Cribs

3. Terminology

3.1 Definitions of Terms Specific to This Standard:

3.1.1 *attachment, n*—accessory with a rigid frame such as a bassinet or changing table that attaches to a non-full size crib/play yard and that, because of its structure, location, or movement, may expose a non-full size crib/play yard occupant to an opening presenting an entrapment hazard. It does not include: (1) items that hang outside the occupant areas, such as organizers and storage bags, (2) canopies that have no rigid frame members running alongside any top rail, and (3) accessories that attach only to another attachment and not directly to the non-full size crib/play yard.

3.1.1.1 *Discussion*—Rationale: Definition applies only to accessories that attach to non-full size crib/play yard, not accessories that attach to bassinet or changing table. This would exclude a changing table that attaches only to a bassinet, since a bassinet occupant is not able to push up on hands and knees, and therefore is not at risk from an entrapment hazard.

3.1.2 *conspicuous, adj*—Describes a label that is visible, when the unit is in a manufacturer's recommended use position, to a person standing near the unit at any one position around the unit but not necessarily visible from all positions.

3.1.3 *cord, n*—length of slender flexible material including monofilaments, rope, woven and twisted cord, plastic and textile tapes, ribbon, and those materials commonly called string.

3.1.4 *corner post, n*—vertical post located at the corner of a product.

3.1.5 *dropside/dropgate, n*—side that is intended to slide or pivot with respect to the frame when the product is in the manufacturer's recommended use position to provide easier access to the occupant.

3.1.6 *dynamic load, n*—application of an impulsive force through free fall of a weight.

3.1.7 *fabric, n*—any woven, knit, coated, laminated, extruded or calendered flexible material that is intended to be sewn, welded, heat sealed, or glued together as an assembly.

3.1.8 *foldable side or end, n*—side or end panel intended to be stationary with respect to the frame when a product is in the manufacturer's recommended use position, but that folds to allow for carrying or storage of the product.

3.1.9 *manufacturer's recommended use position, n*—Any position that is presented by the manufacturer in any descriptive or instructional literature as a normal, allowable, or acceptable configuration for use of the product. This specifically excludes positions that the manufacturer shows in a like manner in its literature to be unacceptable, unsafe, or not recommended.

3.1.10 *mattress, n*—pad with a fabric, vinyl, or other material case filled with resilient material (such as cotton, foam, fiberfill, etc.) used as or on the floor of the unit.

3.1.11 *mesh, n*—mesh may be either a woven fabric in which the warp and filling yarns are interlaced, a knitted fabric in which the wales and courses yarns are interlocked, or any other type of fabric that may be developed that provides openings therein.

3.1.12 *mesh/fabric unit, n*—unit constructed with a rigid frame assembly and a fabric or mesh assembly, or both, used to function as sides, ends, or floor, or a combination thereof.

3.1.13 *non-paper label, n*—any label material (such as plastic or metal) that either will not tear without the aid of tools or tears leaving a sharply defined edge or labels made from fabric.

3.1.14 *occupant, n*—that individual who is in a product that is set up in one of the manufacturer's recommended use positions.

3.1.15 *paper label, n*—any label material that tears without the aid of tools and leaves a fibrous edge.

3.1.16 *protrusion, n*—projection on the unit over which an item worn by a child may become hooked.

3.1.17 *rigid sided product, n*—product with sides/ends constructed of rigid materials like wood, plastic, or metal generally configured as a horizontal rail/vertical slat assembly.

3.1.18 *seam, n*—means of joining fabric components such as sewing, welding, heat sealing, or gluing.

3.1.19 *static load, n*—vertically downward force applied by a calibrated force gage or dead weights.

3.1.20 *stationary side, n*—side or end panel that is not intended to fold, slide, or move with respect to the frame when the product is in the manufacturer's recommended use position.

3.1.21 *strap, n*—piece of flexible material of which the width is significantly greater than the thickness.

3.1.22 *structural failure, n*—damage to a component(s) or assembly resulting in partial separation (greater than 0.04 in. (1 mm) over original configuration), or complete separation of the component(s) or assembly.

4. Calibration and Standardization

4.1 All testing shall be conducted on a concrete floor that may be covered with 1/8-in. (3-mm) thick vinyl flooring cover, unless test instructs differently.

- 4.2 The unit shall be completely assembled, unless otherwise noted, in accordance with the manufacturer’s instructions.
- 4.3 No testing shall be conducted within 48 h of manufacturing.
- 4.4 The product to be tested shall be preconditioned in a room with ambient temperature of $73 \pm 9^{\circ}\text{F}$ ($23 \pm 5^{\circ}\text{C}$) for at least 1 h prior to testing. Testing shall then be conducted within this temperature range.
- 4.5 All testing required by this specification shall be conducted on the same unit.

5. General Requirements

5.1 *Corner Posts:*

5.1.1 No corner post assembly shall extend more than 0.06 in. (1.50 mm) above the upper edge of an end or side panel, whichever is higher, when measured from the lowest point on the upper edge of the end or side panel within 3 in. (76 mm) from the outermost contour of the post or elbow (see Fig. 1).

5.1.1.1 This requirement applies when any drop side/drop gate is in either the raised or lowered position.

5.1.2 The limitations in 5.1.1 do not apply to a corner post assembly that extends at least 16 in. (400 mm) above the uppermost surface of the side rail in its highest position.

5.1.3 Corner posts intended to accept removable vertical extensions made up of two or more segments (such as canopy post extensions) shall not permit the attachment of individual segments such that the resultant vertical extension would be in violation of the dimensional requirements of 5.1.

5.1.4 The dimensional requirements in 5.1 shall also apply to vertical members of circular cribs.

5.2 Prior to testing, any exposed wood parts shall be smooth and free of splinters.

5.3 There shall be no hazardous sharp points or edges as defined by 16 CFR 1500.48 and 16 CFR 1500.49 before or after testing to this specification.

5.4 There shall be no small parts, as defined by 16 CFR 1501, before testing or liberated as a result of testing in accordance with this specification.

5.5 The paint and surface coating on the product shall comply to 16 CFR 1303.

5.6 There shall be no flammable solids as defined in 16 CFR 1500.3 (c) (6) (vi) before or after testing in accordance with this specification.

5.7 *Scissoring, Shearing, or Pinching :*

5.7.1 A product, when in the manufacturer’s recommended use position, shall be designed and constructed to prevent injury to the occupant from any scissoring, shearing, or pinching when members or components rotate about a common axis or fastening point, slide, pivot, fold, or otherwise move relative to one another. Scissoring, shearing, or pinching that may cause injury shall not be permissible when the edges of the rigid parts admit a probe that is greater than 0.210 in. (5.30 mm) and less than 0.375 in. (9.50 mm) diameter at any accessible point throughout the range of motion of such parts.

5.7.2 Products that allow the top rail to be in a lowered position when the unit is erected, as shown in Fig. 2, shall be evaluated for the potential for scissoring, shearing or pinching. Those components of the top rail, its hinges, locks, or mechanism that are deemed to be capable of scissoring, shearing or pinching shall be tested in accordance with 5.7.2.1-5.7.2.4.

5.7.2.1 At all intersections of the *drop top rail* with the *top rail saddle* (Point A, Fig. 2), the insertion of a probe greater than

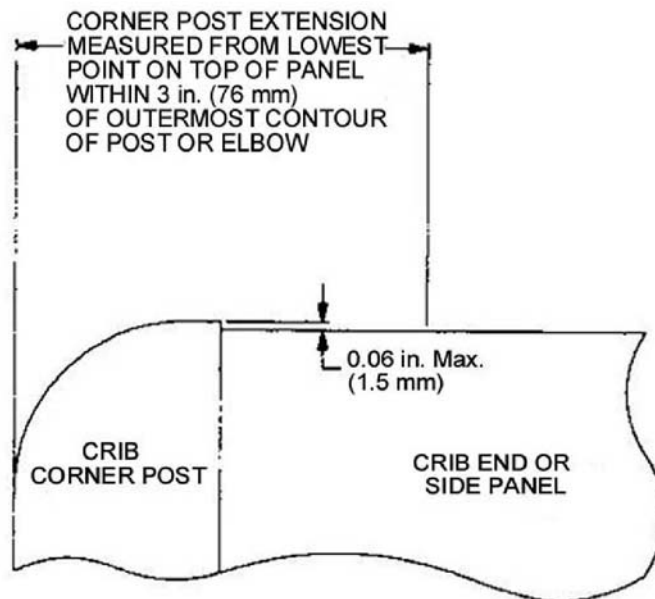

FIG. 1 Illustration of Requirements for Crib Corner Post Extensions

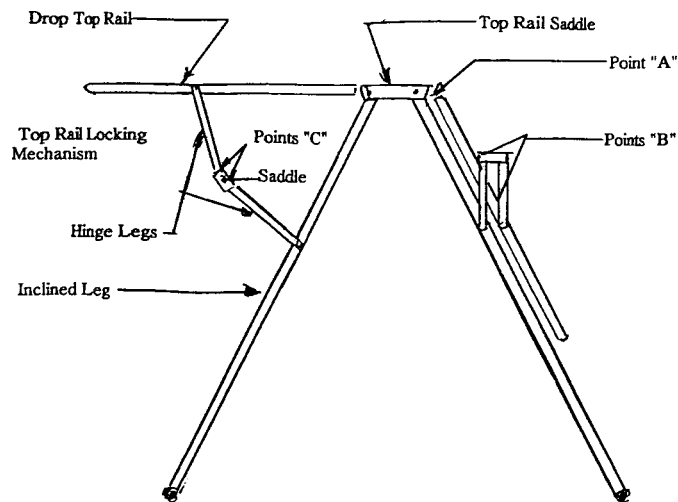

FIG. 2 Product Frame Components

0.210 in. (5.30 mm) in diameter and less than 0.375 in. (9.50 mm) in diameter to a depth of more than 0.210 in. (5.30 mm) shall not be permitted in any position throughout the range of motion of the top rail.

5.7.2.2 All intersections of the *hinge legs* and *saddle* with the *drop top rail* and the *inclined leg* (Point B, Fig. 2) where no padding of ¼ in. (6.30 mm) or less exists, shall allow a 0.375-in. (9.50-mm) diameter probe to pass between adjacent members in any and all positions when rotating the hinge legs about their respective pivots.

5.7.2.3 The hinge legs shall allow a 0.375-in. (9.50-mm) diameter probe to pass between said hinge legs in any and all positions allowed when rotating the hinge legs about their respective pivots.

5.7.2.4 At all intersections of the drop side rail locking mechanism (hinge legs with the saddle) (Point C, Fig. 2) the intersection of the probe greater than 0.210 in. (5.30 mm) in diameter, and less than 0.375 in. (9.50 mm) in diameter, and greater than 0.210 in. (5.30 mm) deep within the intersecting parts in any and all positions shall not be permitted.

5.8 Toy accessories attached to, removed from, or sold with a product, as well as their means of attachment, must meet applicable requirements of Specification F 963.

5.9 *Latching and Locking Mechanisms* :

5.9.1 All latches that are intended to be latched and unlatched during normal use while the child is in the product shall engage automatically when placed in the use position before and after testing. Latches may be manually activated to allow placement into the use position but must engage automatically when released.

5.9.2 Any unit that folds shall have a latching or locking device or other provision in the design that will prevent the unit from unintentionally folding when properly placed in the manufacturer's recommended use position.

5.9.2.1 During and upon completion of all testing, the unit shall remain in its manufacturer's recommended use position.

5.9.3 If a unit is designed with a latching or locking device:

5.9.3.1 That device shall remain engaged and operative after testing.

5.9.3.2 Each single-action locking or latching device that is provided to prevent folding shall require a minimum force of 10 lbf (45 N) to activate the release mechanism when tested in accordance with 8.8.2.

5.9.3.3 Each double-action locking or latching device that is provided to prevent folding shall require two distinct and separate actions for release. There are no force requirements for double-action locking or latching devices.

5.9.3.4 Product designs requiring latching or locking of a top rail(s) to prevent folding that include central hinge(s) and rail assembly(ies) that moves downward when folded, as shown in Fig. 3, shall have a locking device that automatically engages when placed in a manufacturer's recommended use position.

5.9.3.5 No top rail shall give the appearance of being in the manufacturer's recommended use position unless the locking device is fully engaged.

5.10 *Openings*:

5.10.1 Holes or slots that extend entirely through a wall section of any rigid material less than 0.375-in. (9.53-mm) thick and admit a 0.210-in. (5.33-mm) diameter rod shall also admit a 0.375-in. (9.53-mm) diameter rod. Holes or slots that are between 0.210 in. (5.33 mm) and 0.375 in. (9.53 mm) and have a wall thickness less than 0.375 in. (9.53 mm), but are limited in depth to 0.375-in. (9.53-mm) maximum by another rigid surface shall be permissible (see Fig. 4). The product shall be evaluated in all manufacturer's recommended use positions. Holes and openings in surfaces that are in contact with the floor or are below the mattress support and more than 3 in. (76 mm) in from the perimeter of the frame or outer perimeter of the occupant space of a play yard or non full-size crib are exempt from this requirement because they are deemed not accessible to the occupant or child on the outsides of the product.

5.10.2 Openings in the surface of a mattress support made of a rigid material shall be designed to prevent entrapment of fingers, toes, hands, or feet if the occupant can readily move, lift, or fold the mattress to expose the opening. Round openings shall comply

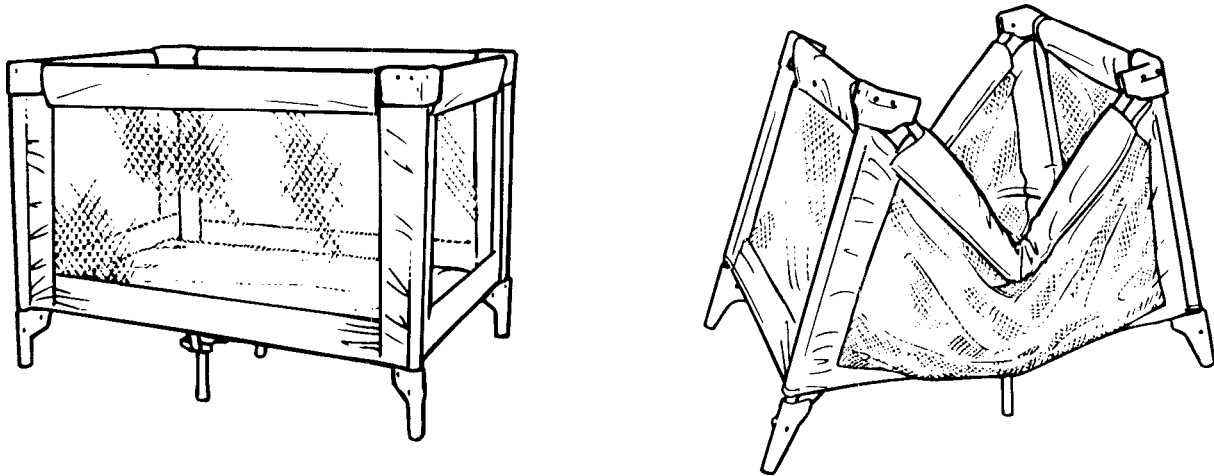
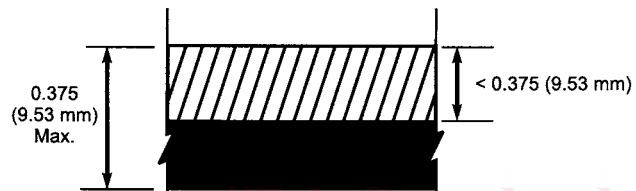

FIG. 3 Top Rail Assembly With Central Hinge(s)



iteh Standards
(<https://standards.iteh.ai>)
Document Preview

ASTM F 406 – 08a

<https://standards.iteh.ai/catalog/standards/sist/8b8328c7-0118-48e3-9f68-a3347db5e5c4/astm-f406-08a>

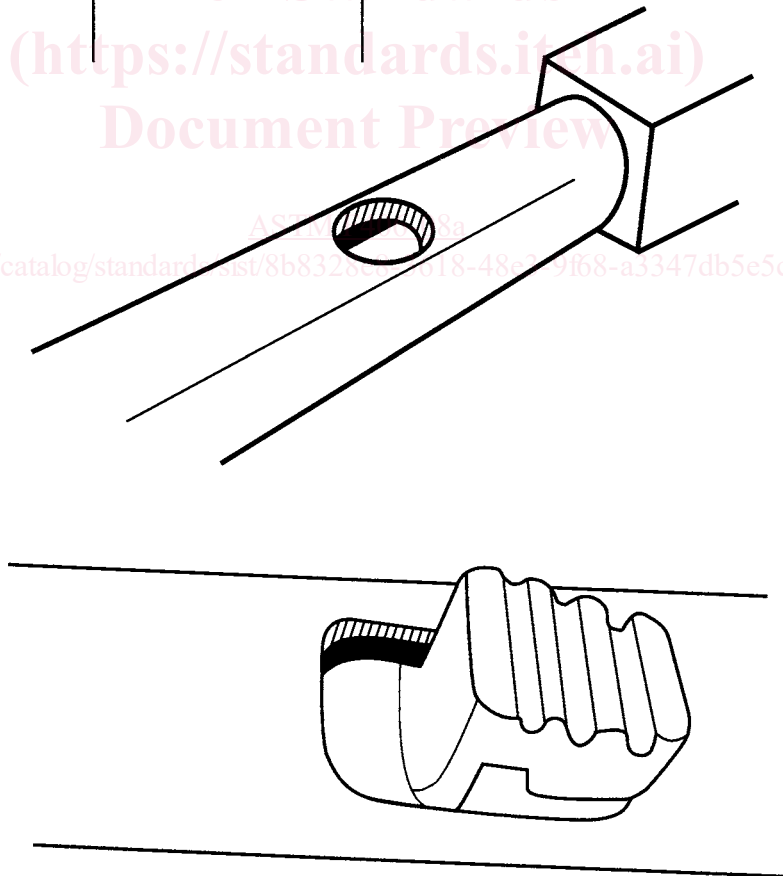

FIG. 4 Opening Example

with 5.10.1 and shall not exceed 1.25 in. (32 mm) in diameter. For other shaped openings, the opening shall comply with 5.10.1 and any linear continuous portion of an opening that admits a 0.375-in. (9.5-mm) diameter rod must fit within a 1.25-in. (32-mm) diameter circle.

NOTE 2—Rationale: The minor dimension of 0.210 and the major dimension of 0.375 is to prevent finger and toe entrapments in accessible holes and slots in juvenile products intended for children 6 to 24 months of age. These dimensional requirements are currently the standard for many juvenile products. This subcommittee is not aware of incident data that would support a change to these dimensions.

Adding the phrase “through a wall section of a rigid material less than 0.375 in.” simplifies the testing procedure and is similar to existing international standards and Specification F 963. International standards (EN 716–1: 1995 and EN 12227–1:1999) state a depth of 10 mm (0.394 in.) which is similar to the proposed 0.375 in. thickness. The thickness of 0.375 is also greater than existing toy standards Specification F 963 and ISO 8124-1:2000, which is only 0.062 in. thick.

The evaluation is limited to holes and openings that are accessible inside the play yard or accessible to a child outside the play yard. The areas of a play yard or non-full-size crib that are not accessible are those components and surfaces on the underside of the floor and support structure that are some distance in from the outer perimeter, for example, tubing, center floor support hub, and the hardboard mattress support.

5.11 *Protective Components*—If the child can grasp components between the thumb and forefinger, or teeth, (such as caps, sleeves, or plugs used for protection from sharp edges, points, or entrapment of fingers or toes) or if there is at least a 0.040-in. (1.00-mm) gap between the component and its adjacent parent component, such component shall not be removed when tested in accordance with 8.16.

5.12 *Labeling*:

5.12.1 Warning labels (whether paper or nonpaper) shall be permanent when tested in accordance with 8.13.

5.12.2 Warning statements applied directly onto the surface of the product by hot stamping, heat transfer, printing, wood burning, etc. shall be permanent when tested in accordance with 8.14.

5.12.3 Nonpaper labels shall not liberate small parts when tested in accordance with 8.15.

5.12.4 Storage pouch or other part with warning statements printed on it, excluding labels, shall be considered permanent if it cannot be removed when tested in accordance with 8.18.

5.13 *Stability*—When subjected to the test described in 8.12, a minimum of three perimeter support points of the product not in a straight line shall remain in contact with the inclined plane. Products with an adjustable mattress support shall be tested with the mattress in the lowest adjustment position.

5.14 *Cord/Strap Length*—No cord or strap made of a flexible material such as fabric, elastic, or plastic having a free stretched length in excess of 7.4 in. (188 mm) shall be attached to a product. Test in accordance with 8.19.

5.15 *Coil Springs*—Any exposed coil spring that is accessible to the occupant, having or capable of generating a space between coils of 0.210 in. (5.30 mm) or greater during static load testing specified in 8.4, 8.6, 8.7, and 8.8 shall be covered or otherwise designed to prevent injury from entrapment.

5.16 *Entrapment in Attachments*—These requirements apply to attachments as defined in 3.1.1. These requirements do not apply to bassinet and changing table attachments that make the non-full size crib/play yard unusable when the attachment is assembled according to the manufacturer’s instructions. The non-full size crib/play yard is considered to be unusable if the attachment requires the non-full size crib/play yard floor to be removed from the non-full size crib/play yard and used in whole in the attachment.

5.16.1 When tested in accordance with the procedure in 8.21.2 openings shall not allow the complete passage of the small head probe shown in Fig. 5, unless they allow the complete passage of the large head probe shown in Fig. 6.

5.16.2 When tested in accordance with the procedure in 8.21.3, all attachment points shall remain attached and any opening exposed by the test shall not allow the complete passage of the small head probe shown in Fig. 5.

5.16.3 *Rationale*—The entrapment test is to address entrapment when an attachment is added to a non-full size crib/play yard that could create an opening that may entrap an occupant’s head. Openings shall be evaluated with attachments in any possible location. Openings are also evaluated after application of a 25-lbf force to the small head probe. This is the same force used to evaluate entrapment in shelves in the changing table standard. A 25-lbf force is also used in evaluating mattress support systems in the current non-full size crib/play yard/non-full-size and full-size crib standards. The small head probe represents the 5th percentile 6-month-old child because that is the youngest child having the developmental abilities to become entrapped.

5.16.4 With the attachment installed on the play yard/non-full size crib per the manufacturer’s instructions, cords and straps on the attachment, whether fastened or unfastened, must not be capable of forming a loop in conjunction with the product that allows complete passage of the small head probe shown in Fig. 5. In addition, restraint straps are to be evaluated as follows:

5.16.4.1 In all possible fastened positions, other than the manufacturer’s intended use position buckled on top of the product surface.

5.16.4.2 When buckled per the manufacturer’s instructions, extended to their greatest length and draped over the side of the product. See Fig. 7. In this position, the restraint straps shall not allow complete passage of the small head probe shown in Fig. 5 below the surface of the attachment.

5.17 *Mattress*:

5.17.1 Each product shall be sold with the mattress pad included.

5.17.2 For mesh/fabric products, the filling material of the mattress such as foam, fiberfill, etc. shall not exceed 1 in. (25 mm) in thickness. The total thickness of the mattress including all fabric or vinyl layers, filling material and any structural members such

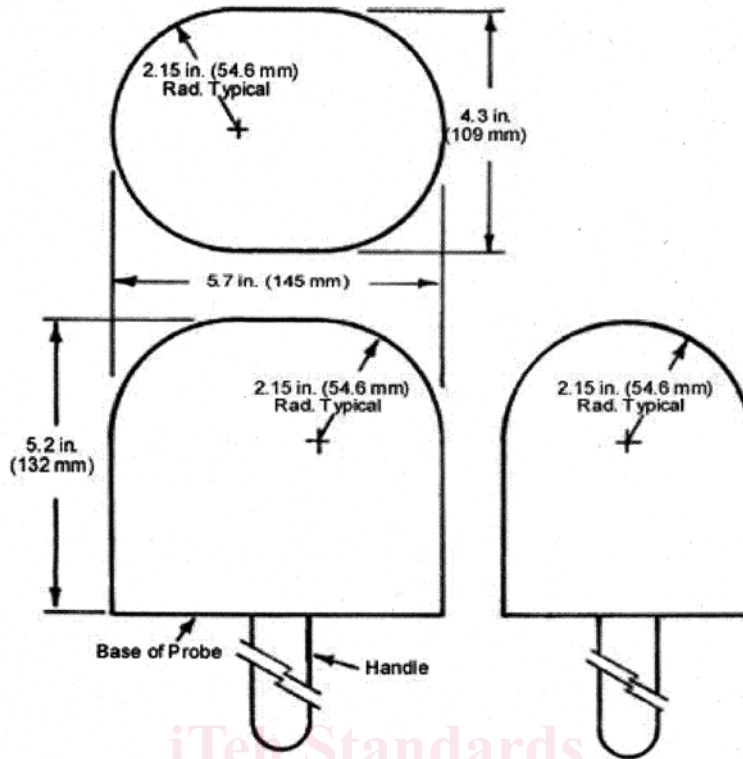

iTen Standards

NOTE—Dimensions are based on a 5th percentile 6-month-old child. Gage may be modified to facilitate testing to allow for pulling of the gage.

FIG. 5 Small Head Probe

as wood, hardboard, etc. shall not exceed 1½ in. (37 mm).

5.18 *Protrusions*—Neither string on the weight gage shall stay attached to a protrusion when tested in accordance with 8.20.

6. Performance Requirements for Rigid Sided Products

6.1 Before and after all testing, the product shall comply with Title 16 Code of Federal Regulations (CFR) Part 1509.

6.2 *Vertical Impact Testing*—These tests assist in evaluating the structural integrity of the unit assembly. Glue joints and other means of fastening are subjected to abusive loads and stresses.

6.2.1 *Mattress Support Testing*:

6.2.1.1 This test consists of dropping an impactor repeatedly onto the mattress pad provided with the product (see 8.1).

6.2.1.2 Upon completion of testing, components attached by glue, screws or other fastening means shall not have separated by more than 0.04 in. (1 mm) over original configuration.

6.2.2 *Side or End Testing, or Both* :

6.2.2.1 This test consists of repeatedly impacting the bottom rail of a unit side or end with a mass. See 8.2.

6.2.2.2 Upon completion of testing, components attached by glue, screws, or other fastening means shall not have separated by more than 0.04 in. (1 mm) over their original configuration.

6.3 *Mattress Support System Testing*— These tests assist in evaluating the integrity of the attachment of the mattress support to the product.

6.3.1 A mattress support that is fixed with respect to the unit frame, is tested in accordance with 8.3. Test failure occurs if the mattress support system becomes detached from the frame at any point of attachment, or if the force cannot be maintained.

6.3.2 A mattress support that is not fixed on opposite sides to the unit frame (for example, a hinged support or a support created by a recessed area in which the mattress support sits) is tested by gradually applying a 25-lbf (110-N) force in any direction to the mattress support to evaluate its attachment to the unit. The force is to be applied to the mattress support in each adjustment position. Test failure occurs if:

6.3.2.1 Any fixed portion of the mattress support system becomes detached from the unit at any point of attachment.

6.3.2.2 Any free-moving portion of the mattress support system that does not return to its intended use position once the force is removed. The force shall be removed after the force of 25 lbf (110 N) has been applied or the edge of the mattress support has been lifted at least 12 in. (300 mm).

6.4 *Side(s) or End(s) Latch Testing, or Both*—This test assists in evaluating the integrity of the dropside(s) or end(s) latching system, or both, under abusive load conditions.

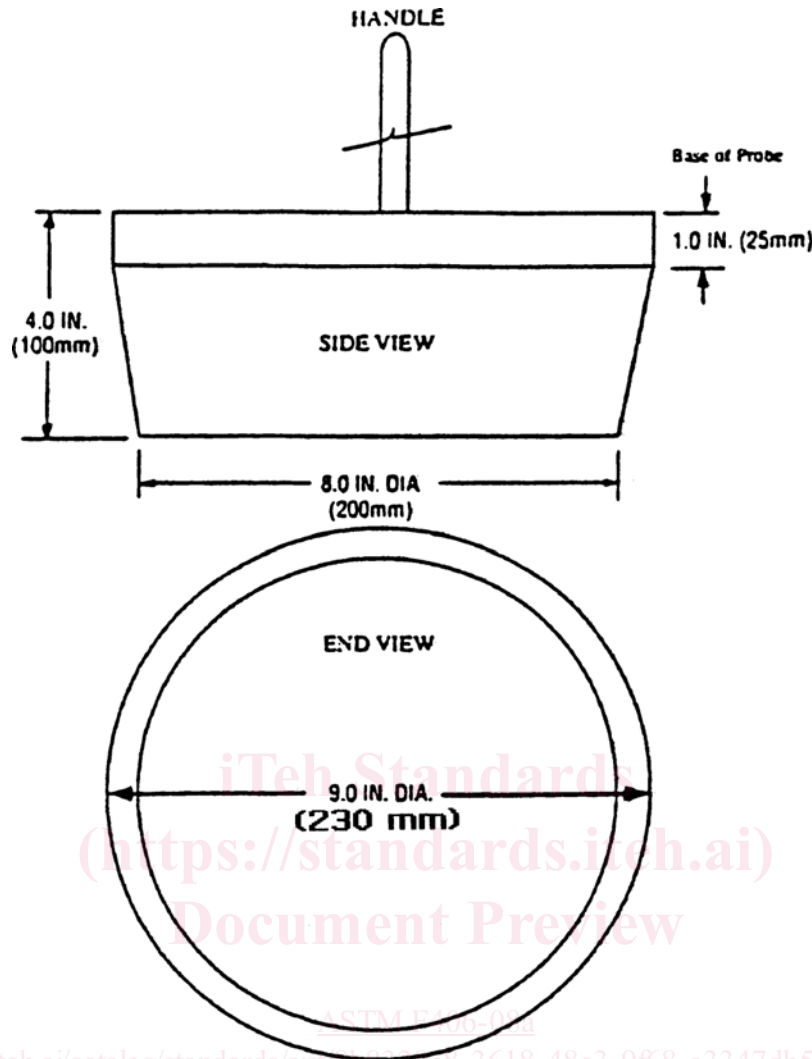

NOTE—The 9.0 in. diameter is based on the back-of-head to tip-of-chin dimension for a 97th percentile 3-year-old.

FIG. 6 Large Head Probe

6.4.1 Dropside Latch Testing:

6.4.1.1 This test consists of horizontally loading the end while a prescribed force is applied to the dropside(s) (see 8.4.3 or 8.4.4).

6.4.1.2 The latching mechanism shall not disengage during testing and shall continue to function in the intended manner upon completion of the testing.

6.4.2 Foldable Side or End Latch Testing:

6.4.2.1 This test consists of loading the latches intended to prevent folding of the side when in the manufacturer's recommended use position (see 8.4.5).

6.4.2.2 The latching mechanism shall not disengage during testing and shall continue to function in the intended manner upon completion of the testing.

6.5 Plastic Teething Rail:

6.5.1 This test consists of deforming the plastic teething rail under load to determine the security of the attachment.

6.5.2 Failure occurs when the feeler gage as defined in 8.5.1.1 can freely enter into a gap created by the deflection or deformation of the plastic teething rail, or both, when tested in accordance with 8.5.

7. Performance Requirements for Mesh/Fabric Products

NOTE 3—Mesh/fabric products that include a rigid side, end, or floor should be tested in accordance with Section 6 on that side, end, or floor.

7.1 *Height of Sides*— With mattress support in its lowest position, the height of sides of a unit shall be a minimum of 20 in. (508 mm) from the top of the non-compressed pad to the top of the side rail when the side rail is in its fully erected position.

7.2 *Side Deflection and Strength* —All tests in this section are to be performed sequentially.