



Designation: D1876-01 ~~Designation: D 1876 - 08~~

Standard Test Method for Peel Resistance of Adhesives (T-Peel Test)¹

This standard is issued under the fixed designation D 1876; the number immediately following the designation indicates the year of original adoption or, in the case of revision, the year of last revision. A number in parentheses indicates the year of last reappraisal. A superscript epsilon (ϵ) indicates an editorial change since the last revision or reappraisal.

This standard has been approved for use by agencies of the Department of Defense.

INTRODUCTION

The accuracy of the results of strength tests of adhesive bonds will depend on the conditions under which the bonding process is carried out. Unless otherwise agreed upon by the manufacturer and the purchaser, the bonding conditions shall be prescribed by the manufacturer of the adhesive. In order to ensure that complete information is available to the individual conducting the tests, the manufacturer of the adhesive shall furnish numerical values and other specific information for each of the following variables:

(1) Procedure for preparation of the surfaces prior to application of the adhesive, the cleaning and drying of metal surfaces, and special surface treatments such as sanding, which are not specifically limited by the pertinent test method.

(2) Complete mixing directions for the adhesive.

(3) Conditions for application of the adhesive, including the rate of spread or thickness of film, number of coats to be applied, whether to be applied to one or both surfaces, and the conditions of drying where more than one coat is required.

(4) Assembly conditions before application of pressure, including the room temperature, length of time, and whether open or closed assembly is to be used.

(5) Curing conditions, including the amount of pressure to be applied, the length of time under pressure, and the temperature of the assembly when under pressure. It should be stated whether this temperature is that of the glue line, or of the atmosphere at which the assembly is to be maintained.

(6) Conditioning procedure before testing, unless a standard procedure is specified, including the length of time, temperature, and relative humidity.

A range may be prescribed for any variable by the manufacturer of the adhesive, if it can be assumed by the test operator that any arbitrarily chosen value within such a range or any combination of such values for several variables will be acceptable to both the manufacturer and the purchaser of the adhesive.

1. Scope

1.1 This test method is primarily intended for determining the relative peel resistance of adhesive bonds between flexible adherends by means of a T-type specimen.

1.2 The values stated in SI units are to be regarded as the standard. The values given in parentheses are provided for information purposes only.

1.3 *This standard does not purport to address all of the safety concerns, if any, associated with its use. It is the responsibility of the user of this standard to establish appropriate safety and health practices and determine the applicability of regulatory limitations prior to use.*

2. Referenced Documents

2.1 *ASTM Standards:*²

B 209 Specification for Aluminum and Aluminum-Alloy Sheet and Plate

¹ This test method is under the jurisdiction of ASTM Committee D14 on Adhesives and is the direct responsibility of D14.80 on Metal Bonding Adhesives. Current edition approved Oct. 10, 2001. Published December 2001. Originally published as D1876-61 T. Last previous edition D1876-00 ϵ 1.

Current edition approved Oct. 1, 2008. Published October 2008. Originally approved in 1961. Last previous edition approved in 2001 as D 1876 - 01.

² For referenced ASTM standards, visit the ASTM website, www.astm.org, or contact ASTM Customer Service at service@astm.org. For *Annual Book of ASTM Standards*, Vol 02.02, volume information, refer to the standard's Document Summary page on the ASTM website.

3. Terminology

3.1 *Definitions*—Many terms in this test method are defined in Terminology D 907.

3.1.1 *peel strength, n*—the average load per unit width of bondline required to separate progressively a flexible member from a rigid member or another flexible member.

3.1.1.1 *Discussion*—Flexible has different meanings in different peel tests, such as “T”, “T,” 180-degree, floating-roller, or climbing-drum. The angle between the members varies with the type of peel test.

3.2 *Definitions of Terms Specific to This Standard:*

3.2.1 *flexible, adj*—indicates that the adherends shall have such dimensions and physical properties as to permit bending them through any angle up to 90° without breaking or cracking.

3.2.2 *T-peel strength, n*—the average load per unit width of bond line required to produce progressive separation of two bonded, flexible adherends, under conditions designated in this test method.

4. Apparatus

4.1 *Tension Testing Machine*, capable of applying a tensile load having the following prescribed conditions:

4.1.1 The machine and loading range selected that the maximum load on the specimen falls between 15 and 85 % of the upper limit of the loading range.

4.1.2 The rate of movement between heads essentially constant under fluctuating loads.

NOTE 1—It is difficult to meet this requirement when loads are measured with a spring-type or pendulum-type weighing device.

4.1.3 The machine equipped with suitable grips capable of clamping the specimens firmly and without slippage throughout the tests.

4.1.4 The machine shall be autographic, giving a chart that can be read in terms of inches of separation as one coordinate and applied load as the other coordinate.

4.1.5 The applied tension as measured and recorded accurate to ±1 % of any reading when calibrated in compliance with Practices E 4 requirements requirements.

4.2 *Conditioning Room or Desiccators* —The conditioning room or desiccators (Note 2) shall be capable of maintaining a relative humidity of 50 ± 2 % at 23 ± 1°C (73.4 ± 1.8°F).

NOTE 2—A saturated solution of calcium nitrate will give approximately 51 % relative humidity at the testing temperature.

5. Test Specimen

5.1 Laminated test panels (see Fig. 1) consist of two flexible adherends properly prepared and bonded together in accordance with the adhesive manufacturer’s recommendations. Specially prepared test panels 152 mm (6 in.) wide by 305 mm (12 in.) long, but bonded only over approximately 241 mm (9 in.) of their length. Test panels of these same dimensions may also be cut from larger, fully laminated panels.

NOTE 3—Direct comparisons of different adhesives can be made only when specimen construction and test conditions are identical.

NOTE 4—Clad aluminum alloy 0.81 mm (0.032 in.) thick conforming to Specification B 209, Alloy 2024-T3, has been found satisfactory as an adherend for structural adhesives. Canvas, coated fabrics, plastics films, and metal foils have also proven to be satisfactory adherends for use with specific adhesives.

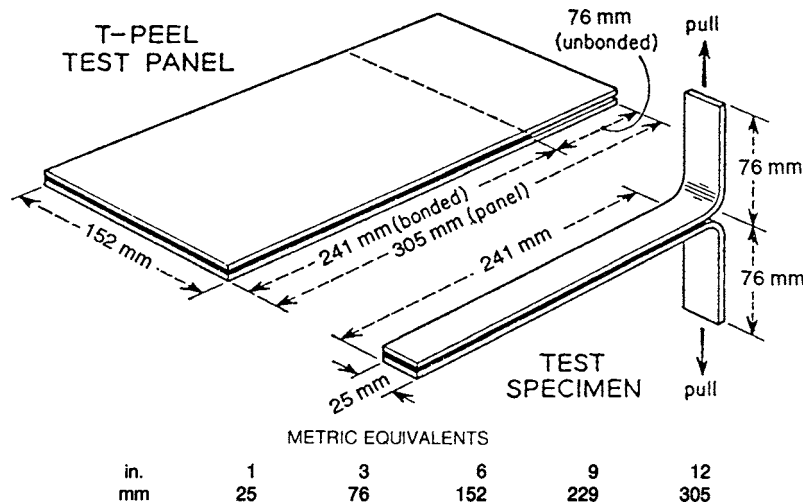

FIG. 1 Test Panel and Test Specimen