



Designation: ~~D6151-97 (Reapproved 2003)~~ Designation: D 6151 - 08

Standard Practice for Using Hollow-Stem Augers for Geotechnical Exploration and Soil Sampling¹

This standard is issued under the fixed designation D 6151; the number immediately following the designation indicates the year of original adoption or, in the case of revision, the year of last revision. A number in parentheses indicates the year of last reapproval. A superscript epsilon (ϵ) indicates an editorial change since the last revision or reapproval.

1. Scope*

1.1 This practice covers how to obtain soil samples using hollow-stem sampling systems and use of hollow-stem auger drilling methods for geotechnical exploration. This practice addresses how to obtain soil samples suitable for engineering properties testing.

1.2 In most geotechnical explorations, hollow-stem auger drilling is combined with other sampling methods. Split barrel penetration tests (Test Method D 1586) are often performed to provide estimates of engineering properties of soils. Thin-wall tube (Practice D 1587) and ring-lined barrel samples (Practice D 3550) are also frequently taken. This practice discusses hole preparation for these sampling events. For information on the sampling process, consult the related standards. Other in situ tests, such as the vane shear Test Method D 2573, can be performed below the base of the boring by access through the drill string.

1.3 This practice does not include considerations for geoenvironmental site characterizations and installation of monitoring wells which are addressed in Guide D 5784.

1.4 This practice may not reflect all aspects of operations. It offers guidance on current practice but does not recommend a specific course of action. It should not be used as the sole criterion or basis of comparison, and does not replace or relieve professional judgment.

1.5

1.5 The values stated in inch-pound units are to be regarded as standard. The values given in parentheses are mathematical conversions to SI units that are provided for information only and are not considered standard.

1.6 Hollow-stem auger drilling for geotechnical exploration often involves safety planning, administration, and documentation. This standard does not purport to specifically address exploration and site safety. It is the responsibility of the user of this standard to establish appropriate safety and health practices and determine the applicability of regulatory limitations prior to its use. Performance of the test usually involves use of a drill rig, therefore, safety requirements as outlined in applicable safety standards, for example OSHA (Occupational Health and Safety Administration) regulations, DCDMA safety manual (1),² drilling safety manuals, and other applicable state and local regulations must be observed.

2. Referenced Documents

2.1 ~~ASTM Standards:~~

~~D420 Guide to Site Characterization for Engineering, Design, and Construction Purposes~~ ASTM Standards:³

D 420 Guide to Site Characterization for Engineering Design and Construction Purposes

D 653 Terminology Relating to Soil, Rock, and Contained Fluids

D 2488 Practice for Description and Identification of Soils (Visual-Manual Procedure)

D 5434 Guide for Field Logging of Subsurface Explorations of Soil and Rock

2.2 *Standards for Sampling of Soil and Rock:*

D 1452 Practice for Soil Investigation and Sampling by Auger Borings

D 1586 Test Method for Penetration Test (SPT) and Split-Barrel Sampling of Soils

~~D1587 Practice for Thin-Walled Tube Geotechnical Sampling of Soils³~~

[†]This practice is under the jurisdiction of ASTM Committee D18 on Soil and Rock and is the direct responsibility of Subcommittee D18.02 on Sampling and Related Field Testing for Soil Investigations.

Current edition approved August 10, 1997, Published December 1997.

¹ This practice is under the jurisdiction of ASTM Committee D18 on Soil and Rock and is the direct responsibility of Subcommittee D18.02 on Sampling and Related Field Testing for Soil Evaluations.

Current edition approved Oct. 1, 2008, Published October 2008. Originally approved in 1997. Last previous edition approved in 2003 as D 6151 - 97 (2003).

² The boldface numbers in parentheses refer to the references at the end of this practice.

³ Annual Book of ASTM Standards, Vol 04.08.

³ For referenced ASTM standards, visit the ASTM website, www.astm.org, or contact ASTM Customer Service at service@astm.org. For *Annual Book of ASTM Standards* volume information, refer to the standard's Document Summary page on the ASTM website.

*A Summary of Changes section appears at the end of this standard.

~~D 2113 Practice for Diamond Core Drilling for Site Investigation~~³ D 1587 Practice for Thin-Walled Tube Sampling of Soils for Geotechnical Purposes

D 2113 Practice for Rock Core Drilling and Sampling of Rock for Site Investigation

~~D 3550 Practice for Ring-Lined Barrel Sampling of Soils~~³ D 3550 Practice for Thick Wall, Ring-Lined, Split Barrel, Drive Sampling of Soils

D 4220 Practices for Preserving and Transporting Soil Samples

D 4700 Guide for Soil Sampling from the Vadose Zone

D 5079 Practices for Preserving and Transporting Rock Core Samples

2.3 *In situ Testing:*

~~D 2573 Test Method for Field Vane Shear Test in Cohesive Soils~~³

~~D 3441 Test Method for Deep, Quasi-Static, Cone and Friction-Cone Penetration Tests of Soil~~³

~~D 4719 Test Method for Pressuremeter Testing in Soils~~³ D 2573 Test Method for Field Vane Shear Test in Cohesive Soil

D 3441 Test Method for Mechanical Cone Penetration Tests of Soil

D 4719 Test Methods for Prebored Pressuremeter Testing in Soils

2.4 *Instrument Installation and Monitoring:*

~~D 4428~~ D 4428/D 4428M Test Methods for Crosshole Seismic Testing

D 4750 Test Method for Determining Subsurface Liquid Levels in a Borehole or Monitoring Well (Observation Well)

~~D 5092 Practice for Design and Installation of Ground Water Monitoring Wells in Aquifers~~³ D 5092 Practice for Design and Installation of Ground Water Monitoring Wells

2.5 *Drilling Methods:*

~~D 5784 Guide for the Use of Hollow-Stem Augers for Geoenvironmental Exploration and the Installation of Subsurface Water-Quality Monitoring Devices~~

~~D 5876 Guide for the Use of Direct Rotary Wireline Casing Advancement Drilling Methods for Geoenvironmental Exploration and the Installation of Subsurface Water-Quality Monitoring Devices~~

3. Terminology

3.1 *Definitions:* Terminology used within this practice is in accordance with Terminology D 653 with the addition of the following (see Figs. 1-5 for typical system components):

3.1.1 *auger cutter head*—the terminal section of the lead auger equipped with a hollow cutting head for cutting soil. The cutter head is connected to the lead auger. The cutter head is equipped with abrasion-resistant cutting devices, normally with carbide surfaces. The cutter can be teeth (usually square or conical), or blades (rectangular or spade design). Cutter head designs may utilize one style cutter or a combination of cutters.

3.1.2 *bit clearance ratio*—a ratio, expressed as a percentage of the difference between the inside diameter of the sampling tube and the inside diameter of the cutting bit divided by the inside diameter of the sampling tube.

3.1.3 *blow-in*—(Practice D 5092)—the inflow of groundwater and unconsolidated material into the borehole or casing caused by differential hydraulic heads; that is, caused by the presence of a greater hydraulic head outside the borehole/casing than inside. Also known as *sanding in* or *soil heave*.

3.1.4 *clean out depth*—the depth to which the end of the drill string (bit or core barrel cutting end) has reached after an interval of drilling. The clean out depth (or drilled depth as it is referred to after cleaning out of any sloughed material or cuttings in the bottom of the drill hole) is normally recorded to the nearest 0.1 ft. (0.03 m).

3.1.5 *continuous sampling devices*—sampling systems which continuously sample as the drilling progresses. Hollow-stem sampling systems are often referred to as continuous samplers because they can be operated in that mode. Hollow-stem sampling systems are double-tube augers where barrel-type samplers fit within the lead auger of the hollow auger column. The double-tube auger operates as a soil coring system in certain subsurface conditions where the sampler barrel fills with material as the augers advance. The barrel can be removed and replaced during pauses in drilling for continuous coring.

3.1.6 *double-tube auger*—an auger equipped with an inner barrel for soil sampling (soil coring). If equipped with an inner barrel and liner, the auger system can be described as a triple-tube auger.

3.1.7 *drill hole*—a cylindrical hole advanced into the subsurface by mechanical means. Also known as borehole or boring.

3.1.8 *drill string*—the complete drilling assembly under rotation including augers, core barrel or pilot bit, drill rods, and connector subassemblies. Drilling depth is determined by knowledge of the total length of the drill string, and by subtracting the string length above a ground surface datum.

3.1.9 *fluid injection devices*—pumps, fittings, hose and pipe components, or drill rig attachments that may be used to inject a fluid within a hollow auger column during drilling.

3.1.10 *HSA*—Hollow stem auger(s). See 3.1.11.

3.1.11 *hollow stem auger*—a cylindrical hollow tube with a continuous helical fluting/fining on the outside, which acts as a screw conveyor to lift cuttings produced by an auger drill head or cutter head bit to the surface.

3.1.12 *in-hole-hammer*—a drop hammer for driving a soil sampling device. The in-hole hammer is designed to run down-hole within the HSA column. It is usually operated with a free-fall wireline hoist capable of lifting and dropping the hammer weight

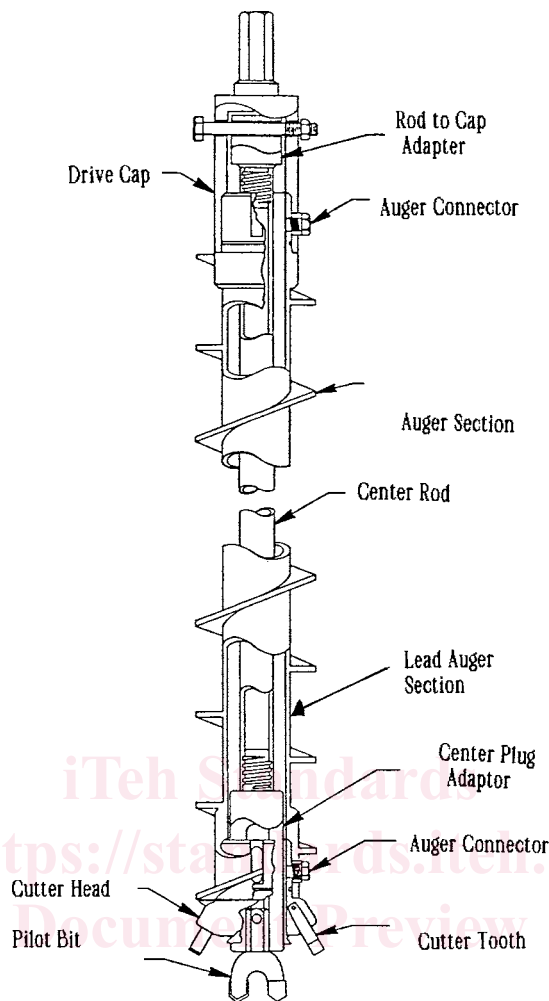

FIG. 1 Rod-Type Auger System With Pilot Bit⁵

to drive the sampler below the HSA column and retrieve the hammer and sampler to the surface. See Fig. 6⁴

3.1.13 *in situ testing devices*—sensors or probes, used for obtaining test data for estimation of engineering properties, that are typically pushed, rotated, or driven in advance of the hollow auger column assembly at a designated depth or advanced simultaneously with advancement of the auger column (see 2.3).

3.1.14 *intermittent sampling devices*—barrel-type samplers that may be rotated, driven, or pushed below the auger head at a designated depth prior to advancement of the auger column (see 2.2).

3.1.15 *lead auger assembly*—the first hollow stem auger to be advanced into the subsurface. The end of the lead auger assembly is equipped with a cutter head for cutting. The lead auger may also contain a pilot bit assembly or sample barrel assembly housed within the hollow portion of the auger. If a wireline system is used, the lead auger assembly will have an adapter housing on top of the first auger containing a latching device for locking the pilot bit assembly or sampling core barrel into the lead auger assembly.

3.1.16 *lead distance*—the mechanically adjusted length or distance that the inner core barrel cutting shoe is set to extend beyond the lead auger assembly cutting head.

3.1.17 *overshot*—a latching mechanism located at the end of the hoisting line (wireline). It is specially designed to latch onto or release the pilot bit or core barrel assemblies. It serves as a lifting device for removing the pilot bit or sampler assembly.

3.1.18 *O-ring*—a rubber ring for preventing leakage between joining metal connections, such as hollow-stem auger sections.

3.1.19 *percent recovery*—percentage which indicates the success of sample retrieval, calculated by dividing the length of sample recovered by the length of sampler advancement.

3.1.20 *pilot bit assembly*—an assembly designed to attach to a drill rod or lock into the lead auger assembly for drilling without sampling. The pilot bit can have various configurations (drag bit, roller cone, tooth bit, or combination of designs) to aid in more efficient or rapid hole advancement.

⁴Annual Book of ASTM Standards, Vol 04.09.

⁵Foremost Mobile, Mobile Drilling Company Inc., 3807 Madison Avenue, Indianapolis, IN.

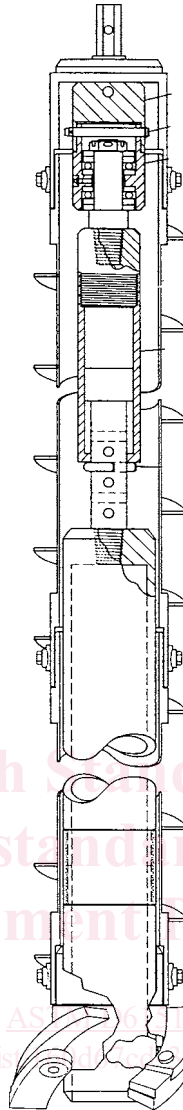

FIG. 2 Example of Rod-Type Sampling System⁴

3.1.21 *recovery length*—the length of sample actually retrieved during the sampling operation.

3.1.22 *sanding in*—a condition that occurs when sand or silt enters the auger after removal of the pilot bit or sampling barrel. See *blow-in*. Sanding in can occur from hydrostatic imbalance or by suction forces caused by removal of the pilot bit or sampling barrel.

3.1.23 *slough*—the disturbed material left in the bottom of the borehole, usually from falling off the side of the borehole, or falling out of the sampler, or off of the auger.

3.1.24 *soil coring, hollow-stem*—The drilling process of using a double-tube HSA system to intermittently or continuously sample the subsurface material (soil).

3.1.25 *wireline drilling, hollow-stem*—a rotary drilling process using a lead auger which holds a pilot bit or sampling barrel delivered and removed by wireline hoisting. Latching assemblies are used to lock or unlock the pilot bit or sampler barrel. The pilot bit or core barrel is raised or lowered on a wireline cable with an overshot latching device.

4. Significance and Use

4.1 Hollow-stem augers are frequently used for geotechnical exploration. Often, hollow-stem augers are used with other sampling systems, such as split barrel penetration resistance testing, Test Method D 1586, or thin-wall tube sampling, Practice D 1587 (see 2.5). Hollow-stem augers may be used to advance a drill hole without sampling using a pilot bit assembly, or they may be equipped with a sampling system for obtaining soil cores. In some subsurface conditions that contain cohesive soils, the drillhole can be successfully advanced without the use of a pilot bit assembly. Intermittent drilling (advancing of the HSA column with or without a pilot bit) and sampling can be performed depending on the intervals to be sampled, or continuous sampling can be performed. During pauses in the drilling and sampling process, in situ testing or other soil sampling methods can be performed

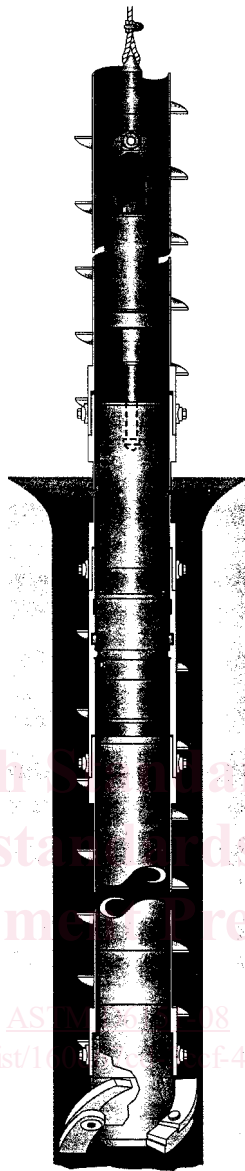

FIG. 3 Example of Wireline Sampling System⁴

through the hollow auger column below the lead auger assembly. At completion of the boring to the depth of interest, the hole may be abandoned or testing or monitoring devices can be installed. Hollow-stem auger drilling allows for drilling and casing the hole simultaneously, thereby eliminating hole caving problems and contamination of soil samples (2). The hollow-stem auger drilling and sampling method can be a satisfactory means for collecting samples of shallow unconsolidated subsurface materials (2). Additional guidance on use can be found in Refs. 2, 3, 4, 5, 6.

4.2 Soil sampling with a double-tube hollow-stem sampling system provides a method for obtaining continuous or intermittent samples of soils for accurate logging of subsurface materials to support geotechnical testing and exploration. A wide variety of soils from clays to sands can be sampled. The sampling systems can be particularly effective in dry soft to stiff clayey or silty deposits but also can work well under saturated conditions. Saturated cohesionless soils such as clean sands may flow and cave during drilling (see Note 1). In many cases, the HSA soil core sampling system can produce very little disturbance to the sample and can provide samples for laboratory tests for measurement of selected engineering properties. Large-diameter soil cores, if taken carefully, can provide Class C and D samples as described in Practice D 4220. The HSA systems can also provide disturbed samples of unsaturated sands and gravels with some structure preserved. Full 5-ft (1.5-m) long cores usually cannot be obtained in unsaturated sands due to increasing side wall friction between the dry sands and inside surface of the sample core barrel. Sample length of 2 to 2.5 ft. (0.60 to 0.75 m) is generally the limit of amount of sample that can be recovered in unsaturated sands before the friction between the sampler and the sand becomes too high and causes blocking or plugging of the sampler. Shorter large diameter core runs of 2.5 ft with the 5-ft sample barrel system, or with a 2.5-ft sample barrel system, have generally proven to result in the best samples.

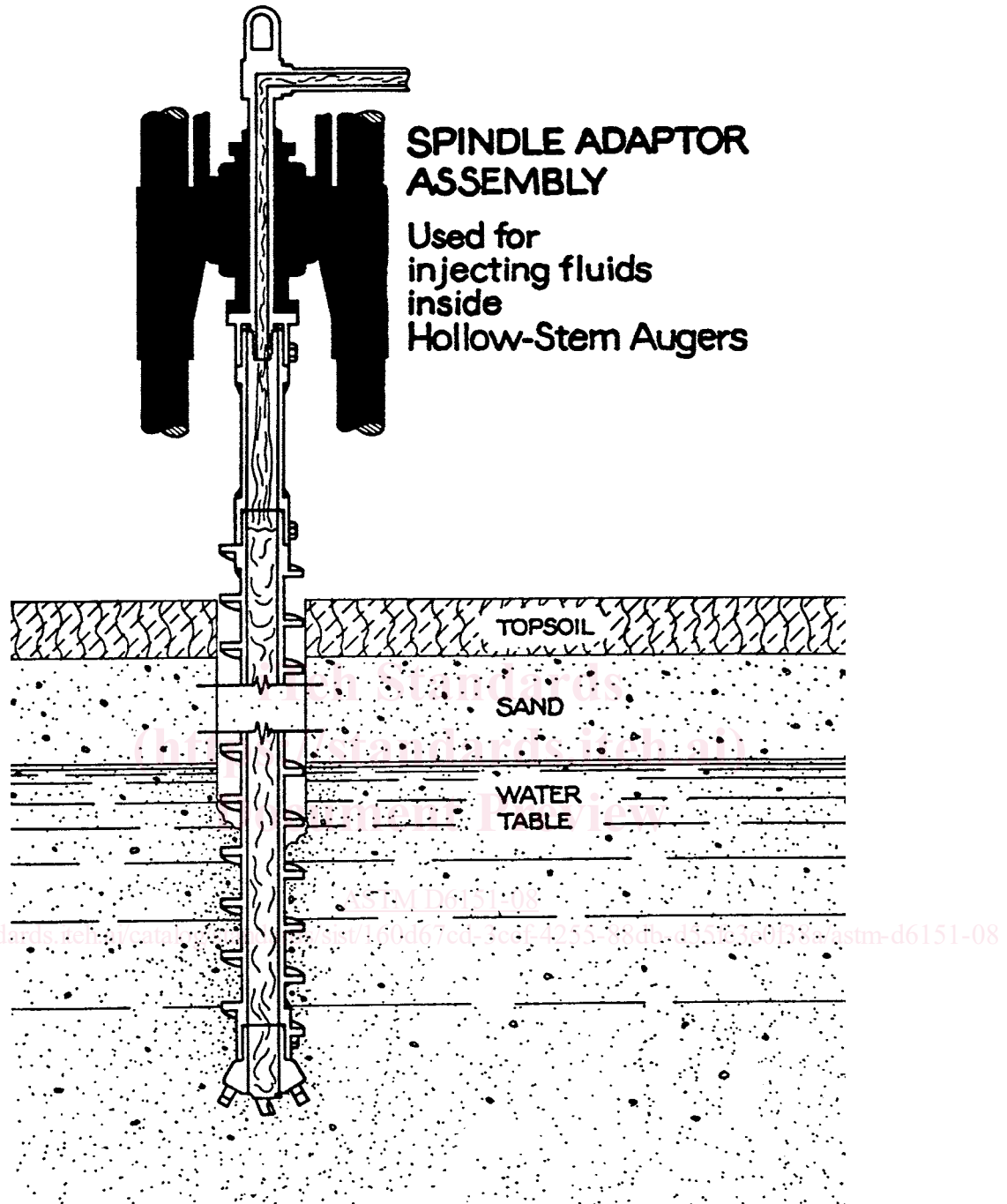

FIG. 4 Spindle Adaptor Assembly

NOTE 1—Research on thin-wall piston sampling in clean sands indicates that in general it is impossible to obtain truly undisturbed samples of saturated clean sands. These soils can dilate or collapse upon insertion of a sampling tube. The hollow-stem auger double-tube system can only obtain partially disturbed samples of sands below the water table.

4.3 Hollow-stem auger drilling is considered a shallow drilling method with maximum depth of drilling of 200 to 300 ft (60 to 90 m) depending on torque and pull down/retract capacity of the drilling equipment and subsurface conditions of the formation(s) encountered. Saturated loose unconsolidated deposits further limit maximum depth that can be attained. Hollow-stem augers can act as casings set through unconsolidated surficial soils and drilling can be converted to other methods (see 2.5) for deeper drilling.

4.4 Drilling and soil sampling can be accomplished with a variety of hollow-stem auger systems. Types of systems can be chosen depending on the advantages of handling, sampling requirements, and subsurface conditions. There are two basic types of systems. One type of system uses inner drill rods or hex rods connecting the sampler or pilot bit assembly to the surface for