



Designation: ~~G74-01~~ Designation: G 74 - 08

Standard Test Method for Ignition Sensitivity of Materials to Gaseous Fluid Impact¹

This standard is issued under the fixed designation G 74; the number immediately following the designation indicates the year of original adoption or, in the case of revision, the year of last revision. A number in parentheses indicates the year of last reapproval. A superscript epsilon (ϵ) indicates an editorial change since the last revision or reapproval.

1. Scope

1.1 This method describes a technique to determine the relative sensitivity of materials to dynamic pressure impacts by gases such as oxygen, air, or blends of gases containing oxygen.

1.2 This method describes the test apparatus and test procedures that may be employed in the evaluation of materials for use in gases under dynamic pressure operating conditions up to gage pressures of 10 000 psi (69 MPa) at ambient temperature.

1.3 This method is primarily a test for ranking of materials. This method is not necessarily valid for determination of the sensitivity of the materials in an “as-used” configuration since the material sensitivity may be altered because of changes in material configuration, usage, and environment. ~~This method can be employed to provide batch-to-batch acceptance data.~~ Acceptability of any material may be based on its performance at a particular test pressure, or test pressure may be varied to determine the reaction threshold of a material, as specified by the user.

1.4 The criteria used for the acceptance, retest, and rejection of materials for any given application shall be determined by the user and are not fixed by this method.

1.5 *This standard does not purport to address all of the safety concerns, if any, associated with its use. It is the responsibility of the user of this standard to establish appropriate safety and health practices and determine the applicability of regulatory limitations prior to use.* For specific precautions see Section 7.

2. Referenced Documents

2.1 ASTM Standards:²

D 1193 Specification for Reagent Water

G 63 Guide for Evaluating Non-Metallic Materials for Oxygen Service

G 93 Practice for Cleaning Methods and Cleanliness Levels for Material and Equipment Used in Oxygen-Enriched Environments

MNL36 Safe Use of Oxygen and Oxygen Systems: Guidelines for Oxygen System Design, Materials Selection, Operations, Storage, and Transportation³

2.2 Military Standards:⁴

MIL-D-16791-E Detergent, General Purpose (Liquid, Nonionic)

MIL-0-27210E, Amendment 1-Oxygen, Aviator’s Breathing, Liquid and Gas

3. Summary of Method

3.1 The gaseous impact test system is designed to expose material specimens or small components/elements to high-velocity (dynamic) gaseous impact environments. The basic configuration consists of a high-pressure accumulator, a high-speed pressurization (impact) valve, test system pressurization lines, test chamber/fixture, test chamber purge and vent systems, and a valve sequencer/control device. Fig. 1 is a schematic of a typical test system.

3.2 The general procedure is to prepare the test specimen, record significant pretest data, and place the test specimen in the test chamber. The test specimen is then subjected to sequential gaseous impacts by alternately opening and closing the test chamber pressurization (impact) and vent valves. The test data obtained may include test chamber pressures and temperatures, test chamber

¹ This method is under the jurisdiction of ASTM Committee G04 on Compatibility and Sensitivity of Materials in Oxygen Enriched Atmospheres and is the direct responsibility of Subcommittee G04.01 on Test Methods.

Current edition approved Sept. 10, 2001-1, 2008. Published January 2002-; October 2008. Originally published as G74-82; approved in 1982. Last previous edition G74-82(1996)¹ approved in 2001 as G 74-01.

² For referenced ASTM standards, visit the ASTM website, www.astm.org, or contact ASTM Customer Service at service@astm.org. For *Annual Book of ASTM Standards*, Vol 14.01, volume information, refer to the standard’s Document Summary page on the ASTM website.

³ Annual Book of ASTM Standards, Vol 14.04.

³ Available from ASTM, 100 Barr Harbor Drive, West Conshohocken, PA 19428.

⁴ Available from ASTM, 100 Barr Harbor Drive, West Conshohocken, PA 19428.

⁴ Available from Standardization Documents Order Desk, Bldg. 4 Section D, 700 Robbins Ave., Philadelphia, PA 19111-5094, Attn: NPODS.

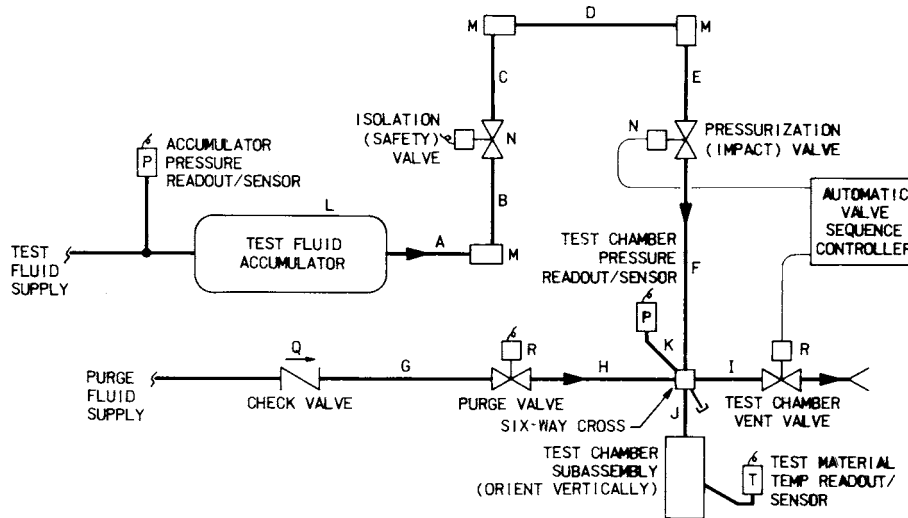

Equipment List:

- A-K See Fig. Fig. 2
- L High-pressure Dwg 4-2219 (or equal)
- M High-pressure Catalog 60-22HF9 (or equal); orient as indicated
- N Flodyne P/N 5A170 (or equal)
- P Teledyne Taber Model 2101 (or equal)
- Q Circle Seal P/N VC1009A (or equal)
- R Flodyne P/N 2A170 (or equal)

FIG. 1 Gaseous Impact Test System Schematic

pressure rise times, pressurization and vent valve actuation times, and sequence times. The test specimen is then removed and examined for any significant changes and evidence of reactions. Pertinent data are recorded. The test is repeated using a fresh specimen for each impact test cycle until the desired user-selected criteria are met.

4. Significance and Use

4.1 This test evaluates the relative sensitivity of materials to dynamic pressure impacts by various gaseous fluid media (may include mixtures of gases).

4.2 Any change or variations in test specimen configurations, thickness, preparation, and cleanliness may cause a significant change in impact sensitivity/reaction.

4.3 A reaction is indicated by an abrupt increase in test specimen temperature or by obvious changes in odor, color, or material appearance, or a combination thereof, as observed during post test examinations. Odor alone is not considered positive evidence that a reaction has occurred.

4.4 Suggested criteria for test completion at a given pressure are:

- 4.4.1 Each specimen is subjected to five impacts.
- 4.4.2 A material passes if no reactions occur in 20 successive samples.
- 4.4.3 A material fails if one reaction occurs in a maximum of 20 or fewer successive samples.
- 4.5 Materials may be ranked by the maximum pressure (pressure threshold) at which they pass the test.
- 4.6 Material acceptance may be on the basis of passing at a selected pressure.

5. Apparatus

5.1 A typical gaseous impact test system used for determining the sensitivity of materials to gaseous impact (adiabatic compression) is schematically depicted in Fig. 1. Details of this typical test system are depicted in Figs. 2-5. The major test system components are described as follows:

5.1.1 The accumulator provides gaseous test fluid storage and is precharged to the desired test pressure (potential energy head). The capacity requirement is dependent on the test chamber and line size and the number of impacts required per test sequence. It is sized to limit static head loss to less than 4 % of initial pressure during any test sequence.

5.1.2 The test chamber shall be pressurized from the base line pressure value (normally atmospheric ambient pressure) to 95 % of test pressure in not less than 10 nor more than 50 ms. This range is not to be construed to be an acceptable variation in any one system, but is the pressure rise time range permitted among different systems. The average pressure rise time of a given system shall vary not more than ± 20 % at a given test pressure during the operational life of the system nor vary more than ± 3 ms for a given test set of 20 impacts.

5.1.3 The fluid lines between the accumulator and pressurization valve shall be sized to minimize flow losses and enable pressurization of test chamber in accordance with 5.1.2. These lines shall contain an isolation valve to provide a safety factor for system operation. The isolation valve shall have a flow factor at least equal to the pressurization (impact) valve.

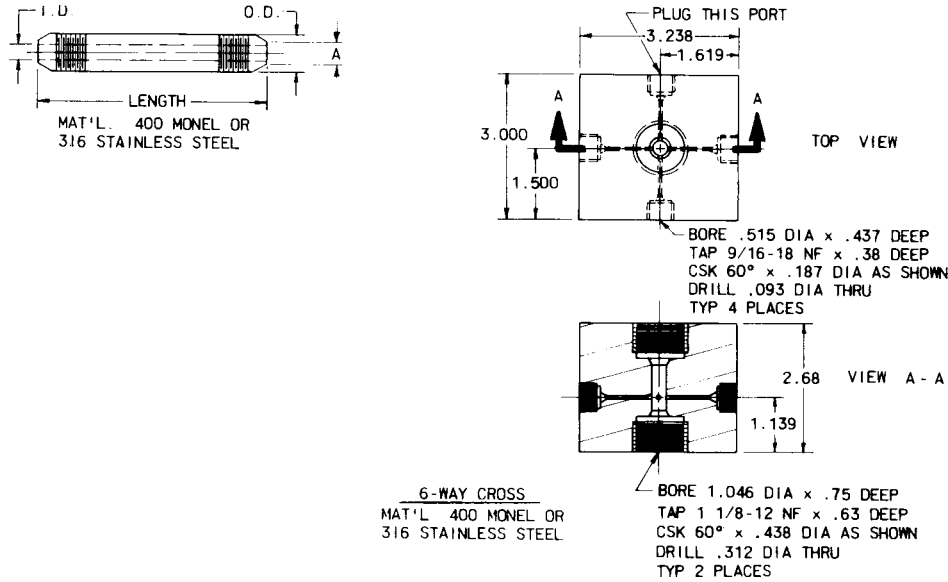

Line	OID		OD		Length		A	
	in.	mm	in.	mm	in.	mm	in.	mm
A	5/16	7.9	9/16	14.3	4.50	114.3	0.375	9.5
B	5/16	7.9	9/16	14.3	12.25	311.2	0.375	9.5
C	5/16	7.9	9/16	14.3	11.96	303.8	0.375	9.5
D	5/16	7.9	9/16	14.3	10.95	278.1	0.375	9.5
E	5/16	7.9	9/16	14.3	3.88	98.6	0.375	9.5
F	5/16	7.9	9/16	14.3	4.00	101.6	0.375	9.5
G	1/16	1.6	1/4	6.4	2.43	61.7	0.125	3.2
H	3/32	2.4	1/4	6.4	5.30	134.6	0.125	3.2
I	3/32	2.4	1/4	6.4	2.25	57.2	0.125	3.2
J	5/16	7.9	9/16	14.3	5.37	136.4	0.125	3.2
K	3/32	2.4	1/4	6.4	2.20	55.9	0.125	3.2

FIG. 2 Test Chamber Purge, Pressurization, and Vent Lines

ASTM G74-08

5.1.4 The test chamber vent valve shall be sized to allow the test chamber pressure to decay to atmospheric pressure between impacts.

NOTE 1—The ability of a given gaseous impact test system to rank materials is based on two basic parameters: the test chamber pressurization rate and the accumulator pressure. There may be variations in the test chamber pressurization rate of different test systems at a given test (accumulator) pressure; however, the test chamber pressurization rate of a given test system shall be maintained within the limits specified in 5.1.2-5.1.4. If these limits are maintained, a test system should be able to rank materials. For example, a properly functioning test system should rank most batches of chloroprene rubbers below most batches of vinylidene fluoride hexafluoropropylene rubbers, which should rank below most batches of polytetrafluoroethylene polymers. This ranking cannot, however, be considered absolute due to material batch differences imposed by contamination, differences in types and amounts of mold release agents, differences in cures, etc. If these limits are maintained, a test system should be able to rank materials. For example, a properly functioning test system should rank most batches of chloroprene rubbers below most batches of vinylidene fluoride hexafluoropropylene rubbers, which should rank below most batches of polytetrafluoroethylene polymers.

5.1.5 The inside diameter and the length of the pressurization line to the test chamber are critical. This section also contains a six-way cross for purge, vent, and instrumentation line connections. All line sections between the accumulator and the test chamber shall be straight and smooth to minimize flow losses. Dimensions of the lines and six-way cross for a typical test system are shown in Fig. 2.

5.1.6 The gaseous impact test chamber subassembly is configured to hold and position the test specimen. It also contains a thermocouple to monitor the test specimen temperature. Other requisites include the ability to readily install and remove the test specimen. Details of a typical test chamber are depicted in Figs. 3-5.

5.2 The test specimen instrumentation and control requirements include the following equipment:

5.2.1 An automatic, remote valve sequencer which controls the opening and closing of the test chamber pressurization (impact) and vent valves during the test so that each impact/vent cycle will be completed in identical, prescribed time periods. It is preset to perform a prescribed number of impact/vent cycles.

5.2.2 Test specimen instrumentation and data requirements include test fluid and test specimen temperatures, system static pressure, and chamber pressures. Additional data may include pressurization (impact) rate or pressure rise time and vent valve actuation and timing, and should include response times required of the instrumentation.

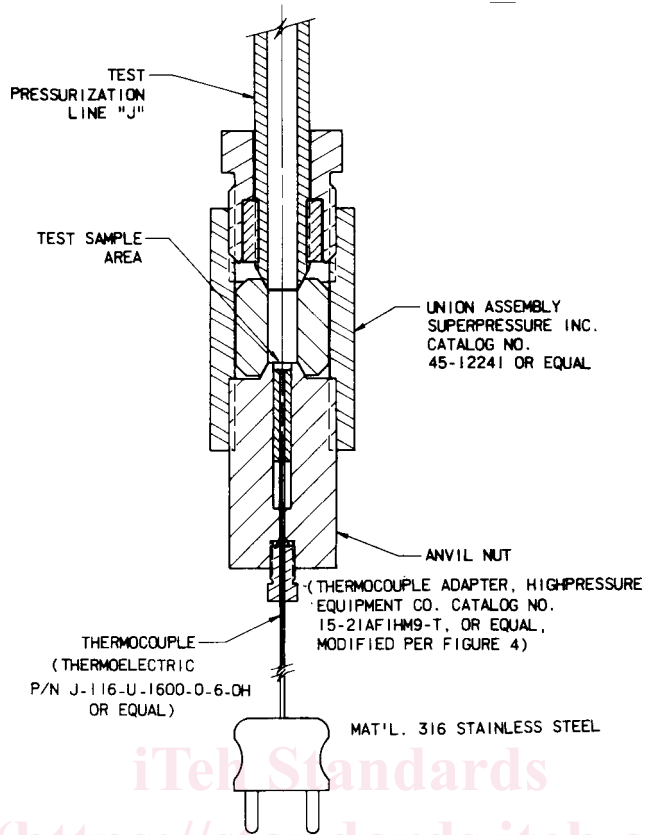

FIG. 3 Test Chamber Subassembly

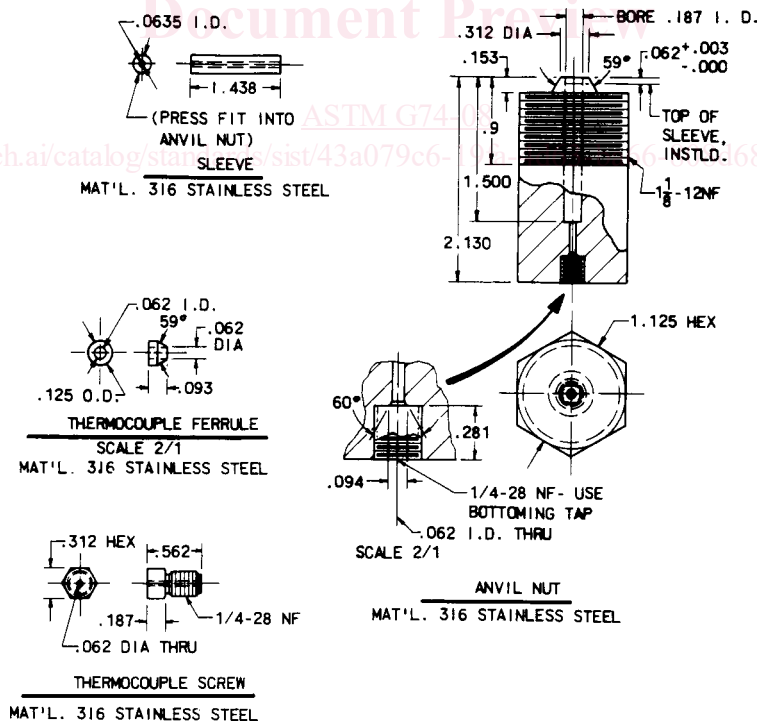

FIG. 4 Anvil Nut Details

6. Reagents and Materials

6.1 *Alkaline Cleaner*, for test chambers, plumbing, and specimen substrates, consisting of a solution of 15 g of sodium hydroxide (NaOH), 15 g of trisodium phosphate (Na₃ PO₄), and 1 L of distilled or deionized water.