**Modular taper interface with ball
track system —**

**Part 1:
Dimensions and designation of shanks**

Interfaces à cône modulaire avec système de serrage à billes —

Partie 1: Dimensions et désignation des queues

**iTeh STANDARD PREVIEW
(standards.iteh.ai)**

ISO 26622-1:2017

<https://standards.iteh.ai/catalog/standards/sist/d8bae962-d664-41af-aabd-fe8e8783fd88/iso-26622-1-2017>



iTeh STANDARD PREVIEW
(standards.iteh.ai)

ISO 26622-1:2017

<https://standards.iteh.ai/catalog/standards/sist/d8bae962-d664-41af-aabd-fe8e8783fd88/iso-26622-1-2017>



COPYRIGHT PROTECTED DOCUMENT

© ISO 2017, Published in Switzerland

All rights reserved. Unless otherwise specified, no part of this publication may be reproduced or utilized otherwise in any form or by any means, electronic or mechanical, including photocopying, or posting on the internet or an intranet, without prior written permission. Permission can be requested from either ISO at the address below or ISO's member body in the country of the requester.

ISO copyright office
Ch. de Blandonnet 8 • CP 401
CH-1214 Vernier, Geneva, Switzerland
Tel. +41 22 749 01 11
Fax +41 22 749 09 47
copyright@iso.org
www.iso.org

Contents

	Page
Foreword	iv
Introduction	v
1 Scope	1
2 Normative references	1
3 Terms and definitions	1
4 Dimensions	1
4.1 General	1
4.2 Tapered hollow shank	2
5 Clamping force	8
6 Designation	8
Annex A (normative) O-rings	9
Annex B (informative) Recommendation for use and application	10

iTeh STANDARD PREVIEW (standards.iteh.ai)

[ISO 26622-1:2017](https://standards.iteh.ai/catalog/standards/sist/d8bae962-d664-41af-aabd-fe8e8783fd88/iso-26622-1-2017)

<https://standards.iteh.ai/catalog/standards/sist/d8bae962-d664-41af-aabd-fe8e8783fd88/iso-26622-1-2017>

Foreword

ISO (the International Organization for Standardization) is a worldwide federation of national standards bodies (ISO member bodies). The work of preparing International Standards is normally carried out through ISO technical committees. Each member body interested in a subject for which a technical committee has been established has the right to be represented on that committee. International organizations, governmental and non-governmental, in liaison with ISO, also take part in the work. ISO collaborates closely with the International Electrotechnical Commission (IEC) on all matters of electrotechnical standardization.

The procedures used to develop this document and those intended for its further maintenance are described in the ISO/IEC Directives, Part 1. In particular the different approval criteria needed for the different types of ISO documents should be noted. This document was drafted in accordance with the editorial rules of the ISO/IEC Directives, Part 2 (see www.iso.org/directives).

Attention is drawn to the possibility that some of the elements of this document may be the subject of patent rights. ISO shall not be held responsible for identifying any or all such patent rights. Details of any patent rights identified during the development of the document will be in the Introduction and/or on the ISO list of patent declarations received (see www.iso.org/patents).

Any trade name used in this document is information given for the convenience of users and does not constitute an endorsement.

For an explanation on the voluntary nature of standards, the meaning of ISO specific terms and expressions related to conformity assessment, as well as information about ISO's adherence to the World Trade Organization (WTO) principles in the Technical Barriers to Trade (TBT) see the following URL: www.iso.org/iso/foreword.html (standards.iteh.ai)

This document was prepared by Technical Committee ISO/TC 29, *Small tools*.

This second edition cancels and replaces the first edition (ISO 26622-1:2008), [Figure 1](#) of which has been technically revised to correct the following:

- gauge diameter, d_2 ;
- tool changer groove diameter, d_3 ;
- ball track dimensioning, related to b_2 , w_2 and d_9 ;
- flange hole dimensioning, related to l_{24} and d_{13} ;
- taper undercut depth;
- divers other corrections in the drawings.

A list of all parts in the ISO 26622 series can be found on the ISO website.

Introduction

The modular taper with ball track system design originated from a joint development effort between two prominent tooling manufacturers in 1985. The benefits to be achieved by the joint development effort were to offer a complete but flexible tooling system-to-machine connection by joining the strengths of two tooling suppliers for the European and North American markets. The modular taper with ball track system product was first introduced at exposition mondiale de la machine-outil (EMO) in Milan in 1987.

Since its introduction, this tooling system has become a globally accepted design for both static and rotating applications. The design characteristics of the modular taper interface with ball track system allow it to be used equally well on both turning and rotating applications. The high mechanical advantage of the modular taper with ball track system design application allows for small springs, small bearings and high spindle speeds. This tool interface uses three areas of contact (one face and two on the taper) that provide a very simple but rigid tool design. These features have made the modular taper with ball track system the quick-change tooling of choice on many tens of thousands of machine tools throughout the world.

The purpose of this document is to ensure compliance of the manufacturing accuracy and quality of the modular taper with the ball track system tool interface.

The International Organization for Standardization (ISO) draws attention to the fact that it is claimed that compliance with this document can involve the use of a patent concerning the modular taper with ball track system.

ISO takes no position concerning the evidence, validity and scope of this patent right.

The holder of this patent right has assured ISO that he/she is willing to waive the exercise of this patent right throughout the world. In this respect, the statement of the holder of this patent right is registered with ISO. Information can be obtained from:

ISO Central Secretariat
International Organization for Standardization (ISO)
CP 56 - CH-1211 Geneva 20, Switzerland

iTeh STANDARD PREVIEW
(standards.iteh.ai)

<https://standards.iteh.ai/catalog/standards/sist/d8bae962-d664-41af-aabd-fe8e8783fd88/iso-26622-1-2017>

iTeh STANDARD PREVIEW
(standards.iteh.ai)

ISO 26622-1:2017

<https://standards.iteh.ai/catalog/standards/sist/d8bae962-d664-41af-aabd-fe8e8783fd88/iso-26622-1-2017>

Modular taper interface with ball track system —

Part 1: Dimensions and designation of shanks

1 Scope

This document specifies the dimensions for modular taper interface with ball track system: tapered shanks for automatic and manual tool exchange to be applied on machine tools (e.g. lathe machines, drilling machines, milling machines and turn/milling machine centres). A range of shank sizes is specified and details of the coolant-sealing O-ring are specified in [Annex A](#).

The shank incorporates a flange with a groove to enable automatic tool exchange. The tools can also be exchanged manually. The clamping of the shank can be realized by the use of locking balls of a standard size and by a variety of mechanisms.

The torque is transmitted at the tail end of the shank by friction, locking elements and keys.

2 Normative references

The following documents are referred to in the text in such a way that some or all of their content constitute requirements of this document. For dated references, only the edition cited applies. For undated references, the latest edition of the referenced document (including any amendments) applies.

ISO 1101, *Geometrical Product Specifications (GPS) — Geometrical tolerancing — Tolerances of form, orientation, location and run-out*

ISO 2768-1, *General tolerances — Part 1: Tolerances for linear and angular dimensions without individual tolerance indications*

ISO 2768-2, *General tolerances — Part 2: Geometrical tolerances for features without individual tolerance indications*

3 Terms and definitions

No terms and definitions are listed in this document.

ISO and IEC maintain terminological databases for use in standardization at the following addresses:

- IEC Electropedia: available at <http://www.electropedia.org/>
- ISO Online browsing platform: available at <http://www.iso.org/obp>

4 Dimensions

4.1 General

Tolerancing of form, orientation, location and run-out shall be in accordance with ISO 1101. Tolerances not specified shall be of tolerance class “m” in accordance with ISO 2768-1 and tolerance class “k” in accordance with ISO 2768-2.

4.2 Tapered hollow shank

The dimensions of modular tapered shanks with the ball track system and the details of automatic tool changer/chip hole configuration are shown in [Figure 1](#) and given in [Table 1](#).

Surface roughness in micrometres
Dimensions in millimetres

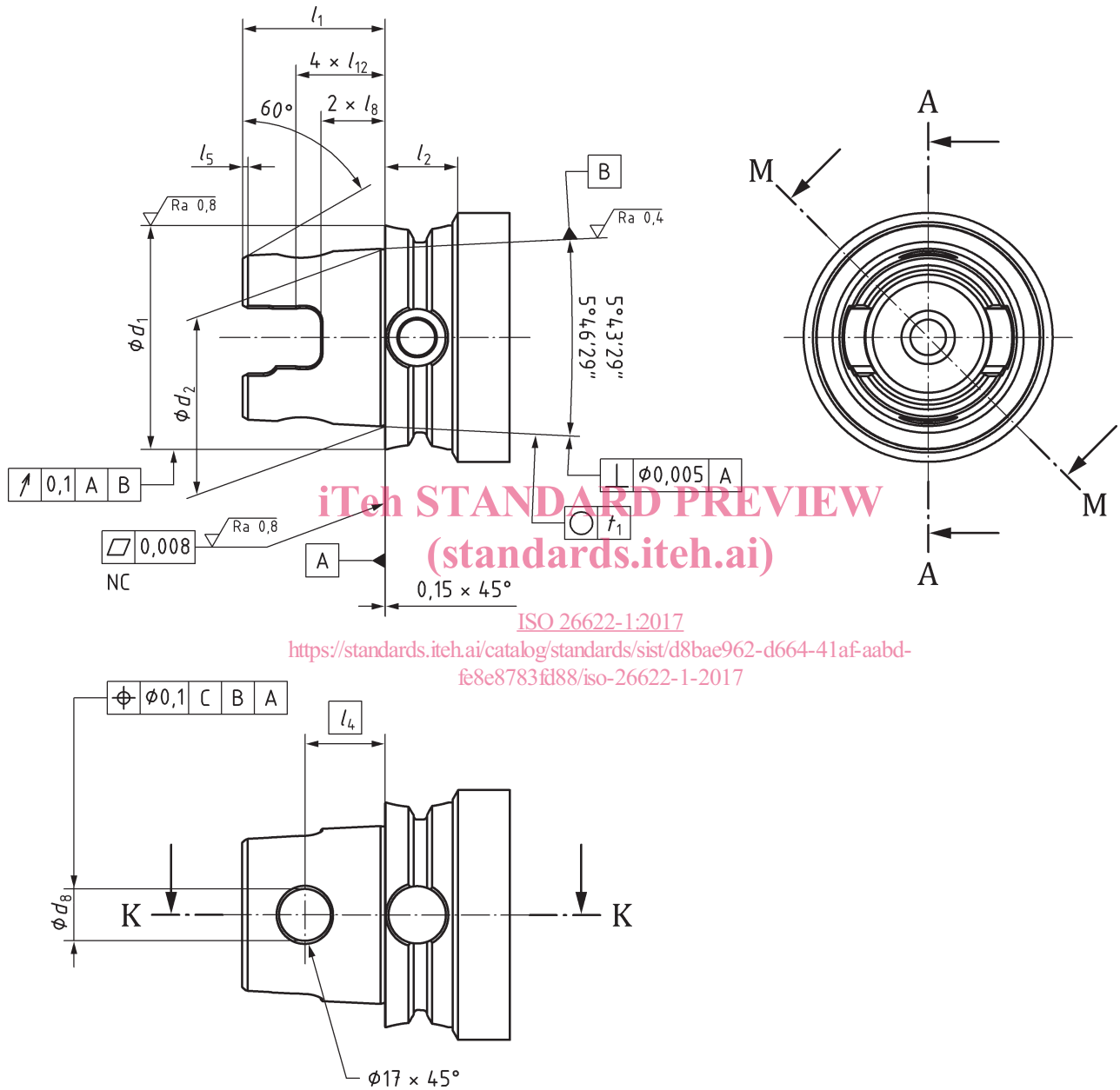
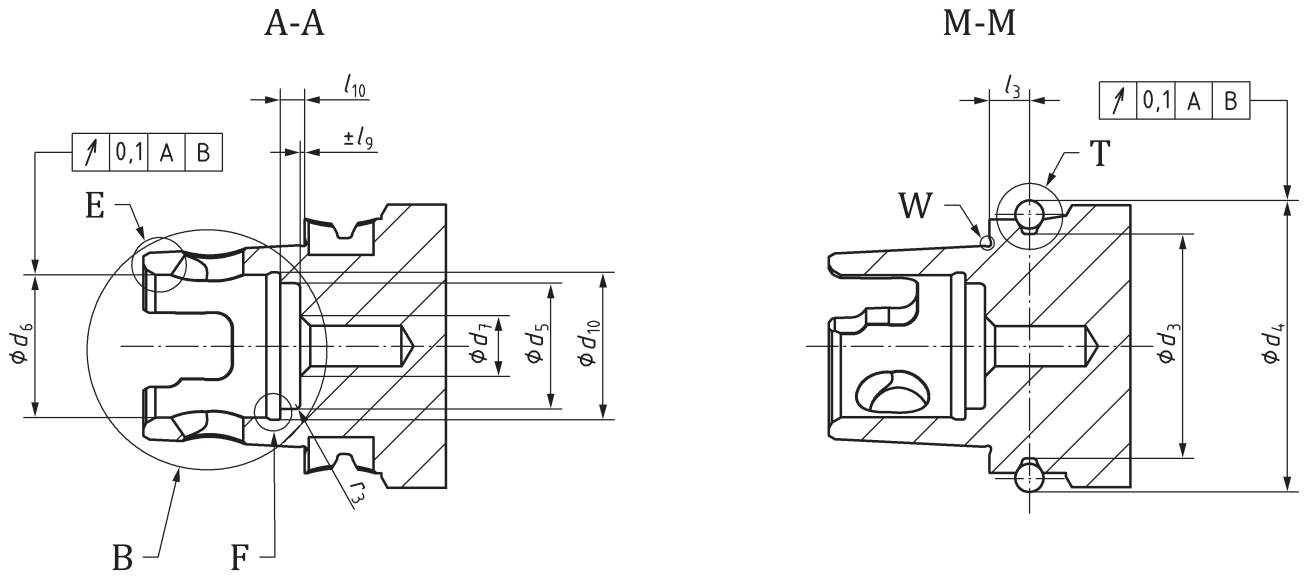

Figure 1 (continued)



iTeh STANDARD PREVIEW
(standards.iteh.ai)

ISO 26622-1:2017

<https://standards.iteh.ai/catalog/standards/sist/d811e962-2024-41af-aabd-f8a710888c262622-1-17>

φ 0,08 C B A

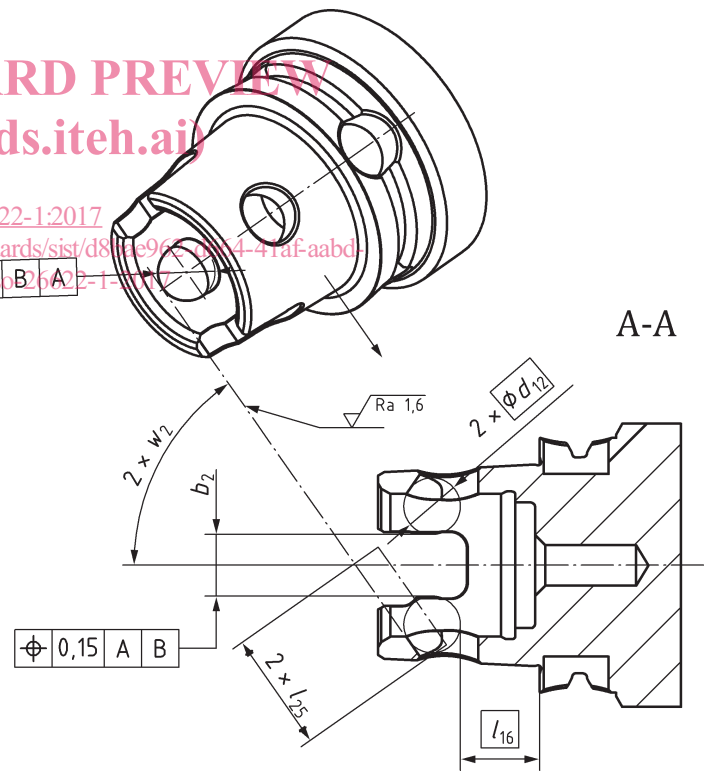

Figure 1 (continued)