

---

---

**Tool holders with rectangular shank  
for indexable inserts —**

**Part 11:  
Style R**

*Porte-plaquette à queue rectangulaire pour plaquettes amovibles —*

*Partie 11: Forme R*  
**iTeh STANDARD PREVIEW**  
**(standards.iteh.ai)**

[ISO 5610-11:2014](https://standards.iteh.ai/catalog/standards/sist/4411add5-d1ba-49df-9e80-f3e8cd1a230a/iso-5610-11-2014)

<https://standards.iteh.ai/catalog/standards/sist/4411add5-d1ba-49df-9e80-f3e8cd1a230a/iso-5610-11-2014>



**iTeh STANDARD PREVIEW**  
**(standards.iteh.ai)**

ISO 5610-11:2014

<https://standards.iteh.ai/catalog/standards/sist/4411add5-d1ba-49df-9e80-f3e8cd1a230a/iso-5610-11-2014>



**COPYRIGHT PROTECTED DOCUMENT**

© ISO 2014

All rights reserved. Unless otherwise specified, no part of this publication may be reproduced or utilized otherwise in any form or by any means, electronic or mechanical, including photocopying, or posting on the internet or an intranet, without prior written permission. Permission can be requested from either ISO at the address below or ISO's member body in the country of the requester.

ISO copyright office  
Case postale 56 • CH-1211 Geneva 20  
Tel. + 41 22 749 01 11  
Fax + 41 22 749 09 47  
E-mail [copyright@iso.org](mailto:copyright@iso.org)  
Web [www.iso.org](http://www.iso.org)

Published in Switzerland

# Contents

	Page
Foreword .....	iv
<b>1 Scope</b> .....	<b>1</b>
<b>2 Normative references</b> .....	<b>1</b>
<b>3 Dimensions</b> .....	<b>1</b>
3.1 General .....	1
3.2 Tool holder style R for square indexable insert shape S .....	2
<b>4 Designation</b> .....	<b>4</b>
<b>5 Material</b> .....	<b>5</b>
<b>6 Design</b> .....	<b>5</b>
6.1 Type of mounting .....	5
6.2 Corner radius, $r_c$ .....	5
6.3 Thickness, $s$ , of indexable insert .....	5
<b>7 Extent of delivery</b> .....	<b>6</b>
<b>8 Marking</b> .....	<b>6</b>
<b>Bibliography</b> .....	<b>7</b>

## iTeh STANDARD PREVIEW (standards.iteh.ai)

[ISO 5610-11:2014](https://standards.iteh.ai/catalog/standards/sist/4411add5-d1ba-49df-9e80-f3e8cd1a230a/iso-5610-11-2014)

<https://standards.iteh.ai/catalog/standards/sist/4411add5-d1ba-49df-9e80-f3e8cd1a230a/iso-5610-11-2014>

## Foreword

ISO (the International Organization for Standardization) is a worldwide federation of national standards bodies (ISO member bodies). The work of preparing International Standards is normally carried out through ISO technical committees. Each member body interested in a subject for which a technical committee has been established has the right to be represented on that committee. International organizations, governmental and non-governmental, in liaison with ISO, also take part in the work. ISO collaborates closely with the International Electrotechnical Commission (IEC) on all matters of electrotechnical standardization.

The procedures used to develop this document and those intended for its further maintenance are described in the ISO/IEC Directives, Part 1. In particular the different approval criteria needed for the different types of ISO documents should be noted. This document was drafted in accordance with the editorial rules of the ISO/IEC Directives, Part 2 (see [www.iso.org/directives](http://www.iso.org/directives)).

Attention is drawn to the possibility that some of the elements of this document may be the subject of patent rights. ISO shall not be held responsible for identifying any or all such patent rights. Details of any patent rights identified during the development of the document will be in the Introduction and/or on the ISO list of patent declarations received (see [www.iso.org/patents](http://www.iso.org/patents)).

Any trade name used in this document is information given for the convenience of users and does not constitute an endorsement.

For an explanation on the meaning of ISO specific terms and expressions related to conformity assessment, as well as information about ISO's adherence to the WTO principles in the Technical Barriers to Trade (TBT) see the following URL: [Foreword - Supplementary information](#)

The committee responsible for this document is ISO/TC 29, *Small tools*, Subcommittee SC 9, *Tools with defined cutting edges, cutting items*.

This second edition cancels and replaces the first edition (ISO 5610-11:2010), of which it constitutes a minor revision.

ISO 5610 consists of the following parts, under the general title *Tool holders with rectangular shank for indexable inserts*:

- *Part 1: General survey, correlation and determination of dimensions*
- *Part 2: Style A*
- *Part 3: Style B*
- *Part 4: Style D*
- *Part 5: Style F*
- *Part 6: Style G*
- *Part 7: Style J*
- *Part 8: Style K*
- *Part 9: Style L*
- *Part 10: Style N*
- *Part 11: Style R*
- *Part 12: Style S*
- *Part 13: Style T*

- *Part 14: Style H*
- *Part 15: Style V*

**iTeh STANDARD PREVIEW**  
**(standards.iteh.ai)**

[ISO 5610-11:2014](https://standards.iteh.ai/catalog/standards/sist/4411add5-d1ba-49df-9e80-fbe8cd1a230a/iso-5610-11-2014)

<https://standards.iteh.ai/catalog/standards/sist/4411add5-d1ba-49df-9e80-fbe8cd1a230a/iso-5610-11-2014>

**iTeh STANDARD PREVIEW**  
**(standards.iteh.ai)**

[ISO 5610-11:2014](#)

<https://standards.iteh.ai/catalog/standards/sist/4411add5-d1ba-49df-9e80-fbe8cd1a230a/iso-5610-11-2014>

# Tool holders with rectangular shank for indexable inserts —

## Part 11: Style R

### 1 Scope

This part of ISO 5610 specifies tool holders with rectangular shank, style R, i.e. with offset shank and cutting edge angle  $\kappa_r = 75^\circ$  for side cutting.

These tool holders are primarily intended for indexable inserts made of hard metal or other cutting materials to be mounted by clamping and to be used for turning operations.

NOTE The symbols for the dimensions shown in the tables of this part of ISO 5610 and the corresponding preferred symbols of properties defined in ISO/TS 13399-2 and ISO/TS 13399-3 are given in ISO 5610-1:2014, Table A.1.

### 2 Normative references

The following documents, in whole or in part, are normatively referenced in this document and are indispensable for its application. For dated references, only the edition cited applies. For undated references, the latest edition of the referenced document (including any amendments) applies.

ISO 5608:2012, *Turning and copying tool holders and cartridges for indexable inserts — Designation*

ISO 5610-1:2014, *Tool holders with rectangular shank for indexable inserts — Part 1: General survey, correlation and determination of dimensions*

### 3 Dimensions

#### 3.1 General

It is not necessary for tool holders to comply with the pictorial representation; only the dimensions given shall be observed.

For determination of dimensions  $h_1$ ,  $f$ , and  $l_1$ , see ISO 5610-1.

For explanation of the designation code for tool holders, see ISO 5608.

NOTE The values of rake angles and inclination angles shown in the figures are recommended values; they can vary according to the application.

3.2 Tool holder style R for square indexable insert shape S

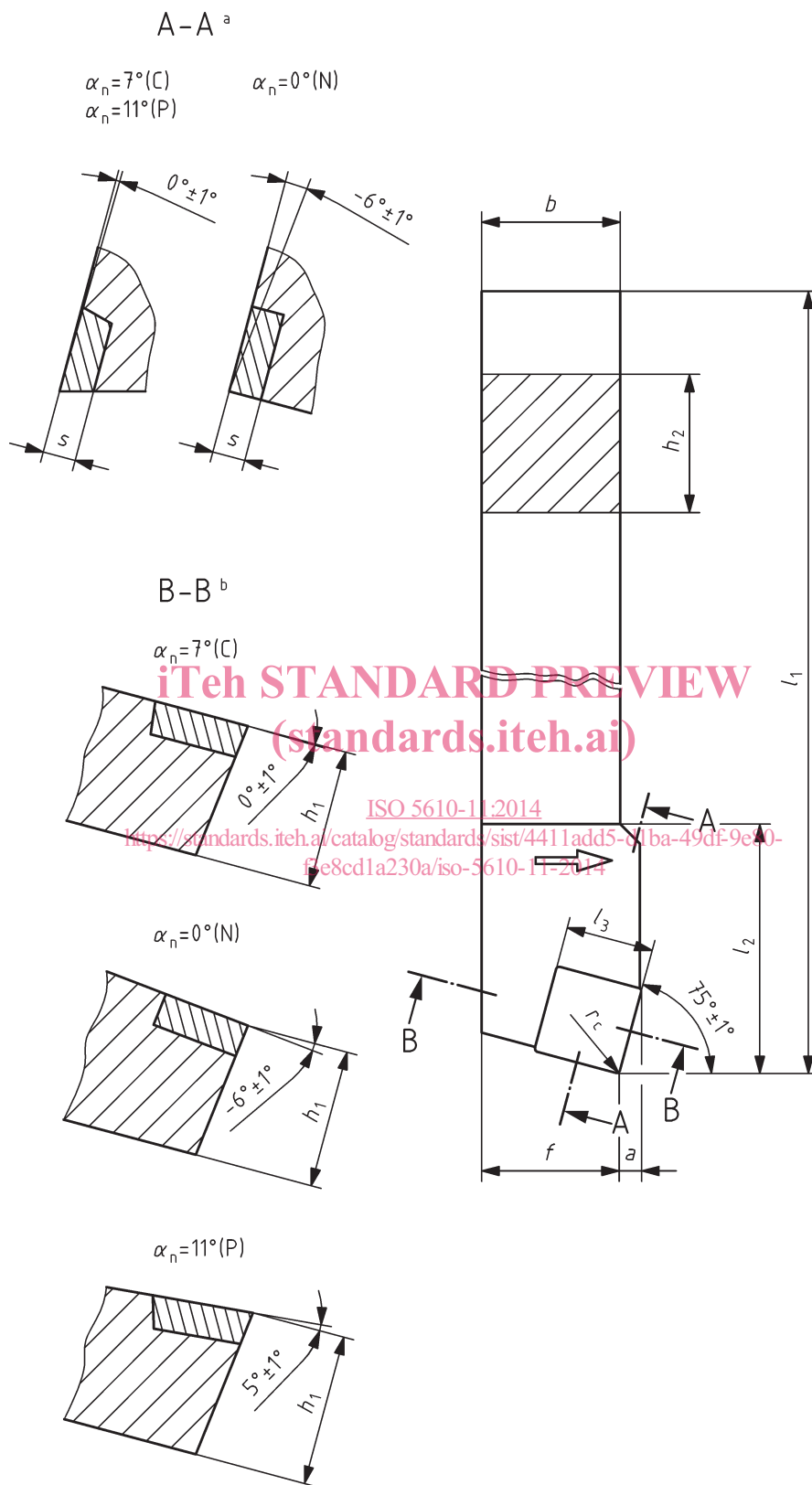

Key

a Inclination angle,  $\lambda_s$ .

b Rake angle,  $\gamma_0$ .

NOTE This figure shows a right-hand tool holder (R); left-hand tool holder (L) laterally reversed.



Figure 1 — Tool holder style R for square indexable insert — S

Table 1

Dimensions in millimetres

Symbol <sup>a</sup>	$h_1$ js13	$b$ h13	$l_3$ ≈	$a$	$f$ +0,5 0	$h_2$ h13	$l_1^a$ k16	$l_2$ max.	$s^b$
SSRCR 1212 — 09	12	12	9,52	2,2	13	12	—	32	3,97
SSRCL 1212 — 09									3,18
PSRNR 1212 — 09									
PSRNL 1212 — 09									
CSRPR 1212 — 09									
CSRPL 1212 — 09	16	16	12,7	3,1	17	16	—	36	4,76
SSRCR 1616 — 12									
SSRCL 1616 — 12									
PSRNR 1616 — 12									
PSRNL 1616 — 12									
SSRCR 2020 — 12	20	20	12,7	3,1	22	20	—	36	4,76
SSRCL 2020 — 12									
PSRNR 2020 — 12									
PSRNL 2020 — 12									
CSRPR 2020 — 12									3,18
CSRPL 2020 — 12									
SSRCR 2525 — 12	25	25	12,7	3,9	27	25	—	36	4,76
SSRCL 2525 — 12									
PSRNR 2525 — 12									
PSRNL 2525 — 12									
CSRPR 2525 — 12									3,18
CSRPL 2525 — 12									
SSRCR 2525 — 15	25	25	15,88	4,6	27	25	—	40	5,56
SSRCL 2525 — 15									6,35
PSRNR 2525 — 15									
PSRNL 2525 — 15									
SSRCR 3225 — 12	32	25	12,7	3,9	27	32	—	36	4,76
SSRCL 3225 — 12									
PSRNR 3225 — 12									
PSRNL 3225 — 12									
CSRPR 3225 — 12									3,18
CSRPL 3225 — 12									

<sup>a</sup> For the selection of length,  $l_1$ , the dash can be replaced by the dimensions of ISO 5610-1:2014, Table 2. For letter symbols identifying the tool length, see ISO 5608:2012, Table 6.

<sup>b</sup> Insert thickness without shim, if applicable.