**Acoustics — Specification of test
tracks for measuring noise emitted by
road vehicles and their tyres**

*Acoustique — Spécification des surfaces d'essai pour le mesurage du
bruit émis par les véhicules routiers et leurs pneumatiques*

iTeh STANDARD PREVIEW
(standards.iteh.ai)

[ISO 10844:2014](https://standards.iteh.ai/catalog/standards/sist/f760722a-e887-4c62-8994-7f9e9e44e31c/iso-10844-2014)

<https://standards.iteh.ai/catalog/standards/sist/f760722a-e887-4c62-8994-7f9e9e44e31c/iso-10844-2014>



iTeh STANDARD PREVIEW
(standards.iteh.ai)

ISO 10844:2014

<https://standards.iteh.ai/catalog/standards/sist/f760722a-e887-4c62-8994-7f9e9e44e31c/iso-10844-2014>



COPYRIGHT PROTECTED DOCUMENT

© ISO 2014

All rights reserved. Unless otherwise specified, no part of this publication may be reproduced or utilized otherwise in any form or by any means, electronic or mechanical, including photocopying, or posting on the internet or an intranet, without prior written permission. Permission can be requested from either ISO at the address below or ISO's member body in the country of the requester.

ISO copyright office
Case postale 56 • CH-1211 Geneva 20
Tel. + 41 22 749 01 11
Fax + 41 22 749 09 47
E-mail copyright@iso.org
Web www.iso.org

Published in Switzerland

Contents

	Page
Foreword.....	iv
Introduction.....	v
1 Scope	1
2 Normative references	1
3 Terms and definitions	1
4 Requirements of the test track	3
4.1 Size and geometry.....	3
4.2 Surface properties of the propagation area.....	7
4.3 Surface properties of the drive lane.....	7
4.4 Conformity tests.....	7
4.5 Homogeneity of surface properties.....	9
4.6 Stability with time and maintenance.....	9
4.7 Break-in of the test track.....	9
5 Measurement methods and data processing	9
5.1 Irregularity measurement methods.....	9
5.2 Texture measurements methods.....	10
5.3 Acoustic absorption measurement method.....	10
6 Conformity report	10
7 Practices from different countries	12
8 Summary of improvements on the 1994 edition	12
Annex A (informative) Calculation of the Expected pass-by noise level difference from texture level variation of road surface (END)	13
Annex B (informative) Maintenance and stability of acoustic performance of test surface over time	18
Annex C (informative) Examples of test track construction practices	19
Annex D (informative) Improvements on ISO 10844:1994	43
Bibliography	44

Foreword

ISO (the International Organization for Standardization) is a worldwide federation of national standards bodies (ISO member bodies). The work of preparing International Standards is normally carried out through ISO technical committees. Each member body interested in a subject for which a technical committee has been established has the right to be represented on that committee. International organizations, governmental and non-governmental, in liaison with ISO, also take part in the work. ISO collaborates closely with the International Electrotechnical Commission (IEC) on all matters of electrotechnical standardization.

The procedures used to develop this document and those intended for its further maintenance are described in the ISO/IEC Directives, Part 1. In particular the different approval criteria needed for the different types of ISO documents should be noted. This document was drafted in accordance with the editorial rules of the ISO/IEC Directives, Part 2 (see www.iso.org/directives).

Attention is drawn to the possibility that some of the elements of this document may be the subject of patent rights. ISO shall not be held responsible for identifying any or all such patent rights. Details of any patent rights identified during the development of the document will be in the Introduction and/or on the ISO list of patent declarations received (see www.iso.org/patents).

Any trade name used in this document is information given for the convenience of users and does not constitute an endorsement.

For an explanation on the meaning of ISO specific terms and expressions related to conformity assessment, as well as information about ISO's adherence to the WTO principles in the Technical Barriers to Trade (TBT) see the following URL: Foreword - Supplementary information

The committee responsible for this document is ISO/TC 43, *Acoustics*, Subcommittee SC 1, *Noise*, in collaboration with ISO/TC 22, *Road vehicles*.

This third edition cancels and replaces the second edition (ISO 10844:2011), of which it constitutes a minor revision.

Introduction

In general, the road surface parameters affecting the noise emission of vehicles are the texture and sound absorption characteristics. In addition, the mechanical impedance and the skid resistance properties of the surface layer can also influence measured noise levels.

In order to minimize the variation in rolling sound emission and vehicle sound emission measurements made at different testing locations, it is therefore necessary to specify the relevant surface properties and recommend carefully the properties of the materials, design, and construction of the test surface.

The principal objective of this International Standard is to provide a revised specification of the surface which improves the reproducibility of measurement.

This International Standard is designed in a way that test tracks conforming to this International Standard are compatible with the first edition, but in addition the variability of properties is reduced.

It is important that the test provides a high degree of reproducibility between different test sites and that the surface design should not only minimize the inter-site variation of tyre or road noise, but should also ensure that the propagation of noise is unaffected by the surface used. This latter consideration precludes the use of road surfaces which have open textures and which have the property of absorbing noise from the power unit and other related sources.

In relation to the first edition, this International Standard includes, including more restrictive specifications of the surface and recommendations for the test track construction process and maintenance. The basic properties of the surface remain unchanged.

The users of this International Standard are encouraged to measure END_T and to communicate the data to the ISO/TC 43/SC 1 for analysis before the next periodical review.

Furthermore, this International Standard recommends a non-destructive test method for periodical checking of the surface characteristics.

This International Standard is quoted in several International Standards (e.g. the ISO 362 series, ISO 13325).

iTeh STANDARD PREVIEW
(standards.iteh.ai)

ISO 10844:2014

<https://standards.iteh.ai/catalog/standards/sist/f760722a-e887-4c62-8994-7f9e9e44e31c/iso-10844-2014>

Acoustics — Specification of test tracks for measuring noise emitted by road vehicles and their tyres

1 Scope

This International Standard specifies the essential characteristics of a test surface intended to be used for measuring vehicle and tyre or road noise emissions.

The surface design given in this International Standard

- produces consistent levels of tyre or road sound emission under a wide range of operating conditions including those appropriate to vehicle sound testing,
- minimizes inter-site variation,
- provides minor absorption of the vehicle sound sources, and
- is consistent with road-building practice.

NOTE For the purposes of this International Standard, the terms noise and sound are used interchangeably.

2 Normative references

The following documents, in whole or in part, are normatively referenced in this document and are indispensable for its application. For dated references, only the edition cited applies. For undated references, the latest edition of the referenced document (including any amendments) applies.

ISO 362-1, *Measurement of noise emitted by accelerating road vehicles — Engineering method — Part 1: M and N categories*

ISO 13472-2, *Acoustics — Measurement of sound absorption properties of road surfaces in situ — Part 2: Spot method for reflective surfaces*

ISO 13473-1, *Characterization of pavement texture by use of surface profiles — Part 1: Determination of mean profile depth*

ISO 13473-3, *Characterization of pavement texture by use of surface profiles — Part 3: Specification and classification of profilometers*

ISO/TS 13473-4, *Characterization of pavement texture by use of surface profiles — Part 4: Spectral analysis of surface profiles*

EN 13036-7, *Road and airfield surface characteristics — Test methods — Part 7: Irregularity measurement of pavement courses: the straightedge test*

3 Terms and definitions

For the purposes of this document, the following terms and definitions apply.

3.1

sound absorption coefficient

α

fraction of the sound power incident on the test object that is absorbed within the test object for a plane wave at normal incidence

Note 1 to entry: Expressed as a percentage, it is called sound absorption.

3.2 surface profile

3.2.1 texture profile

two-dimensional sample of pavement texture generated if a sensor, such as the tip of a needle or a laser spot, continuously touches or shines on the pavement surface while it is moved along a line on the surface

Note 1 to entry: It is described by two coordinates: one along the surface plane, called “distance” (the abscissa), and the other in a direction normal to the surface plane, called “amplitude” (the ordinate).

3.2.2 irregularity

maximum distance of a surface from the measurement edge of the straightedge between two contact points of the straightedge when placed perpendicular to the surface

Note 1 to entry: Pavement characteristics at longer wavelengths than 0,5 m are considered to be above that of texture and are referred to here as irregularity.

Note 2 to entry: See [Figure C.1](#).

3.2.2.1 longitudinal irregularity

irregularity in the longitudinal axis of the track

3.2.2.2 transversal irregularity

irregularity in the direction perpendicular to the axis of the track

3.2.3 straightedge

device used for measuring the deviation from a plane

3.2.4 megatexture

deviation of a pavement surface from a true planar surface with the characteristic dimensions along the surface of 50 mm to 500 mm, corresponding to texture wavelengths with one-third-octave bands including the range of 63 mm to 500 mm of centre wavelengths

Note 1 to entry: Peak-to-peak amplitudes normally vary in the range of 0,1 mm to 50 mm. This type of texture is the texture which has wavelengths in the same order of size as a tyre or road interface and is often created by potholes or “waviness”. It is usually an unwanted characteristic resulting from defects in the surface. Surface roughness with longer wavelengths than megatexture is referred to as irregularity.

3.2.5 macrotexture

deviation of a pavement surface from a true planar surface with the characteristic dimensions along the surface of 0,5 mm to 50 mm, corresponding to texture wavelengths with one-third-octave bands including the range of 0,63 mm to 50 mm of centre wavelengths

Note 1 to entry: Peak-to-peak amplitudes can normally vary in the range of 0,1 mm to 20 mm. This type of texture is the texture which has wavelengths of the same order of size as tyre tread elements in the tyre or road interface. Surfaces are normally designed with a sufficient macrotexture to obtain suitable water drainage in the tyre or road interface. The macrotexture is obtained by suitable proportioning of the aggregate and mortar of the mix or by surface finishing techniques.

3.2.6 microtexture

deviation of a pavement surface from a true planar surface with the characteristic dimension along the surface below 0,5 mm, corresponding to texture wavelengths with one-third-octave bands with centre wavelengths less than or equal to 0,50 mm

3.3 gradient and cross fall

3.3.1

gradient

ratio of the height difference and the length measured along the longitudinal axis of the drive lane, expressed as a percentage

3.3.2

cross fall

height difference expressed as a percentage of the length measured along the transversal axis of the drive lane

3.4

propagation area

part of the test track on each side of the drive lane

Note 1 to entry: See [Figure 1](#).

3.5

drive lane

part of the test track where the vehicle runs

3.6

stiffness

ratio of a normal force and resulting displacement

3.7

dense asphalt concrete

asphalt in which the aggregate particles are essentially continuously graded to form an interlocking structure

Note 1 to entry: [SOURCE: EN 13108-1] <https://standards.iteh.ai/catalog/standards/sist/f760722a-e887-4c62-8994-7f9e9e44e31c/iso-10844-2014>

3.8

mean profile depth

average value of the height difference between the profile and a horizontal line through the highest peak (the peak level) over a 100-mm long baseline

Note 1 to entry: [SOURCE: ISO 13473-1:1997, 3.5.4]

4 Requirements of the test track

4.1 Size and geometry

4.1.1 Size

The test track shall consist of two areas, a drive lane and a propagation area. The dimensions shall comply with [Figure 1](#) and [Table 1](#).

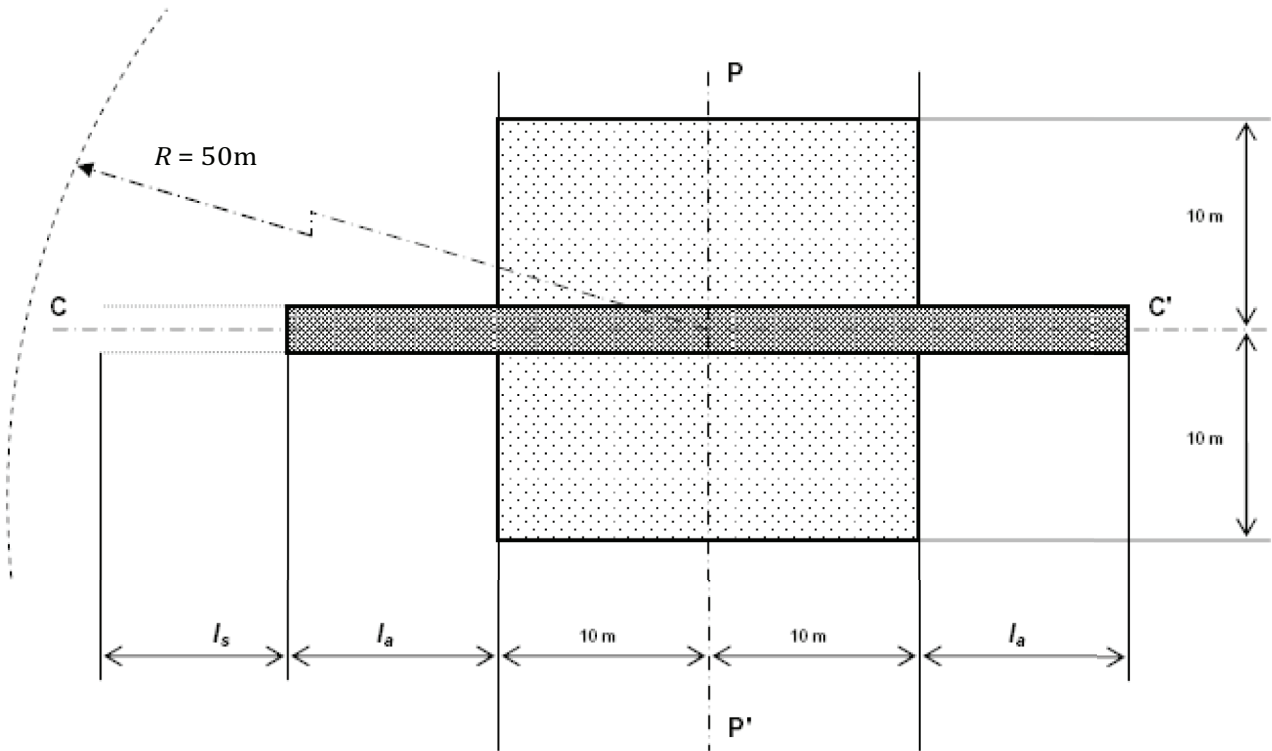

iTeh STANDARD PREVIEW

Key

- l_s construction run-up section
- l_a drive lane extension beyond propagation area
- CC' drive lane centre line
- PP' microphone line
- light-grey area propagation area
- dark-grey area with dotted line drive lane

Figure 1 — Size of the test track

A drive lane with a length of l_a and width of at least 3,0 m that is centred around line PP'. The value of l_a is defined in Table 1.

Table 1 — Minimum drive lane extension length

Length	For testing tyres, passenger cars, motorcycles, light duty vehicles, and trucks	For long vehicles with rear engine, having a distance of more than 10 m between the reference point and the front axle (reference point as defined in ISO 362-1)
l_a	10 m	20 m ^a

^a 20 m is necessary only for the exit side (BB'), as defined in ISO 362-1, of the test track according to the purpose of this requirement.

For the stabilization of the laying process, a minimum length of $l_s = 60$ m is recommended on at least one side.

The propagation area shall extend at least 10 m from the centre of the drive lane and at least 10 m at both sides of the line PP'.

Within a radius of 50 m around the centre of the track, the space shall be free of large reflecting objects such as fences, rocks, bridges, or buildings.

NOTE Buildings outside the 50 m radius can have significant influence if their reflection focuses on the test track.

4.1.2 Geometry

Drive lane

The drive lane shall fulfil the following requirements:

- for acceptance of the test track only, transverse irregularities equal to or less than 0,003 m and longitudinal irregularities equal to or less than 0,002 m, measured with the straightedge according to EN 13036-7;
- for periodical checking of the test track only, transverse irregularities equal to or less than 0,005 m and longitudinal irregularities equal to or less than 0,005 m, measured with the straightedge according to EN 13036-7;
- for acceptance only, deviation from the horizontal plane in transverse direction of 1,0 % maximum (see [Figure 2](#)) and in a longitudinal direction of 0,5 % maximum.

It is recommended that the irregularities requirements be fulfilled starting from the microphone line to cover the drive lane plus 10 m from the end of the section l_a on both sides.

Propagation area

- The propagation area shall have irregularities equal to or less than 0,02 m, measured with the straightedge according to EN 13036-7.
- The propagation area can have one or both sides lower than the drive lane. Cross fall in transverse direction, measured using an appropriate instrument, shall be equal or less than 2,0 % (see [Figure 2](#)).

The slope should be designed in such a way that the draining of water is possible.

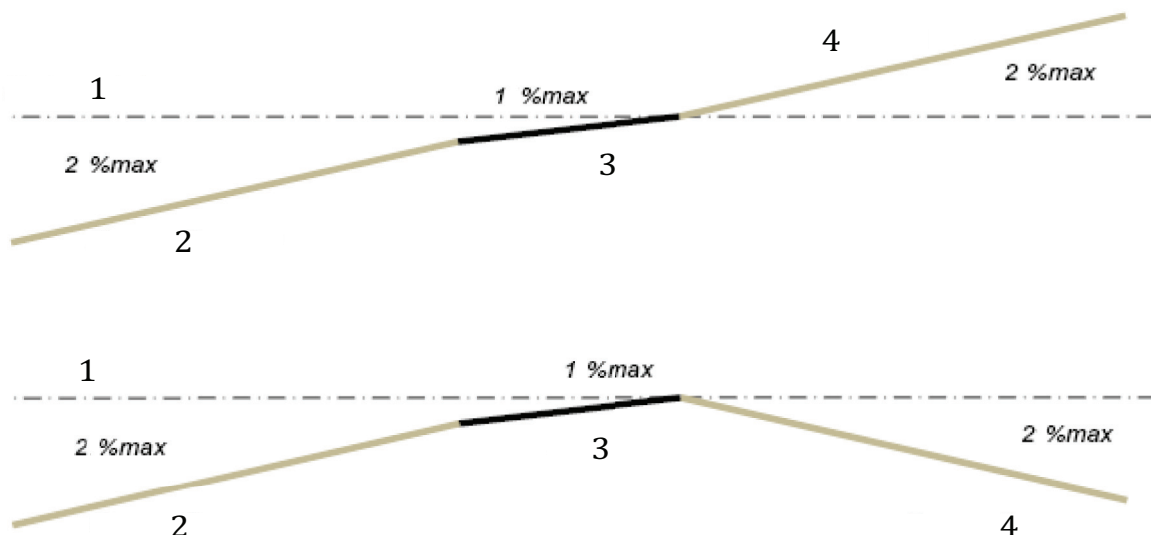
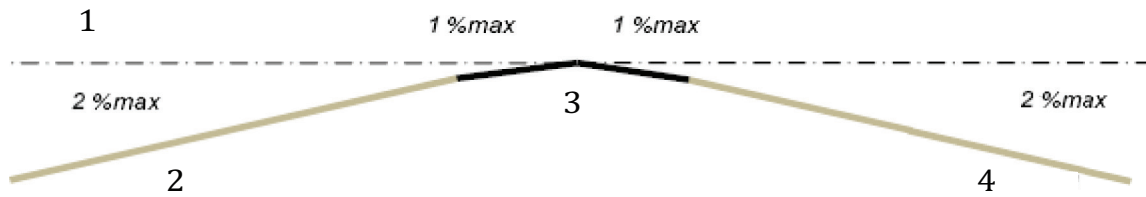

Figure 2 — (continued)



Key

- 1 horizontal plane
- 2 propagation area
- 3 drive lane
- 4 propagation area
- 1 % max allowed drive lane cross fall
- 2 % max allowed propagation area cross fall

Figure 2 — Propagation area slope in transverse direction

— Steps or discontinuities between the propagation area and the drive lane shall be $0^{+0,02}_0$ m (see [Figure 3](#)).

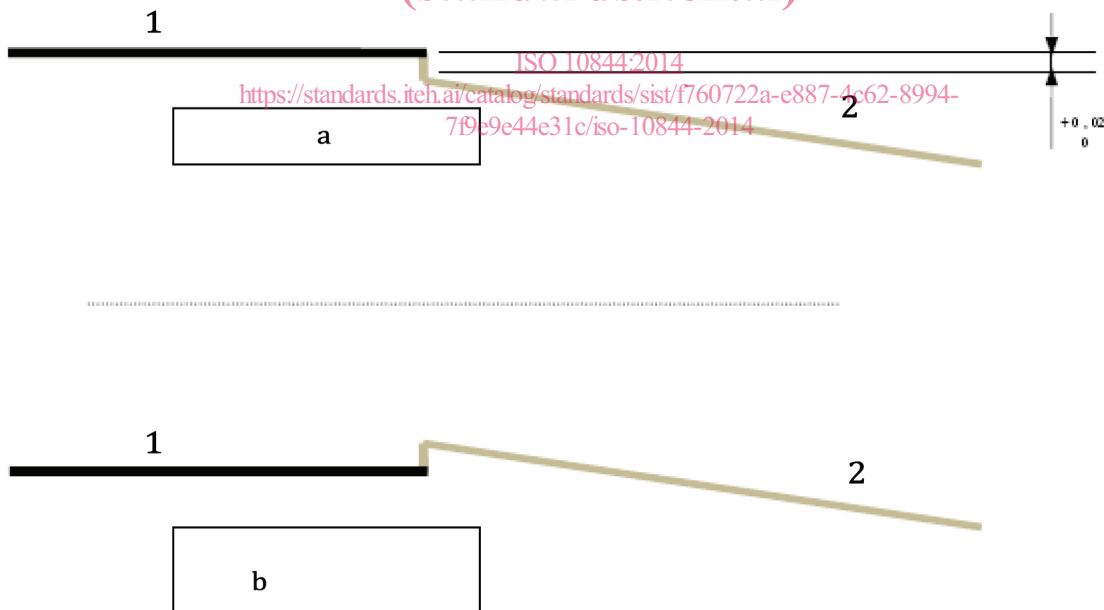

Key

- 1 drive lane
- 2 propagation area
- a Allowed step $\leq 0,02$ m.
- b Not allowed step even if $\leq 0,02$ m.

Figure 3 — Propagation area — Steps or discontinuities

4.2 Surface properties of the propagation area

The average of the values of the sound absorption in each one-third-octave band between 315 Hz and 1 600 Hz central frequency shall be less than or equal to 10 %. The sound absorption coefficient shall be measured according to 5.3.

Location and number of measurement points are given in 4.4.

4.3 Surface properties of the drive lane

The surface of the drive lane shall:

- a) be dense asphalt concrete;
- b) exhibit a sound absorption equal to or less than 8 % in any one-third-octave band between 315 Hz and 1 600 Hz when measured according to 5.3;
- c) have a maximum chipping size of 8 mm (tolerance allowed between 6,3 mm to 10 mm);
- d) have a thickness of the wearing course greater than or equal to 30 mm;
- e) have a mean profile depth (MPD), measured according to ISO 13473-1, of 0,5 mm \pm 0,2 mm;
- f) have a target sieving curve for the aggregate, as described in Figure 4;
- g) have no elastic material (rubber, polyurethane, etc.) applied on the top layer or sublayers except for the modification of bitumen that is less than 1 % of the mass of the total mix.

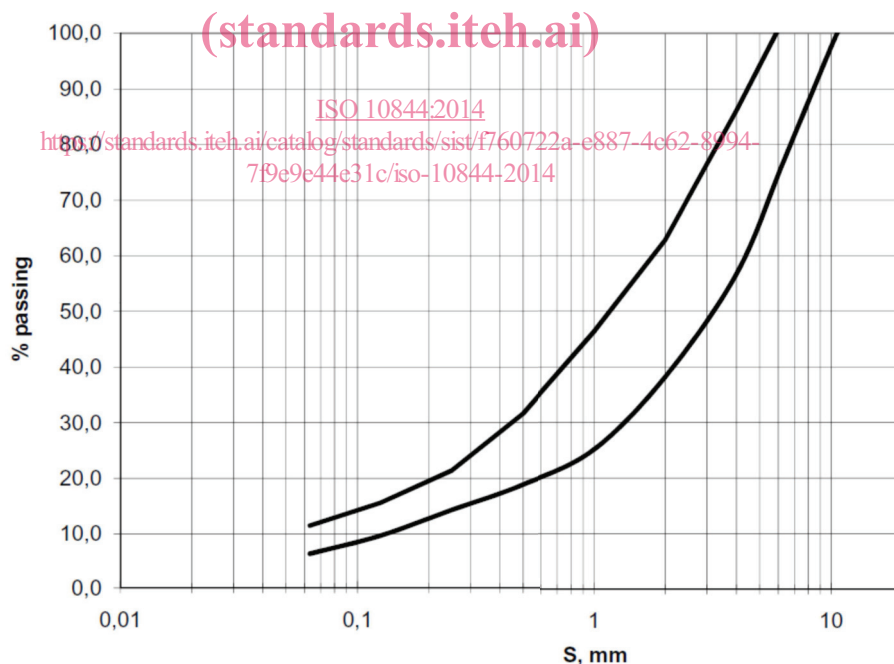

Figure 4 — Sieving curve area

NOTE Until more results for validation are available, END_T is not part of the normative part of this International Standard. Polymer-modified Bitumen (PmB) allows higher temperature operation and reduced surface wear.

4.4 Conformity tests

- a) The surface properties for each requirement shall be determined at the following occasions:
 - 1) before the acceptance of the track (make reference to Table 2);

- 2) during the periodical checking of the track (make reference to [Table 2](#)).
- b) All measurements shall be made along the total length of the drive lane in each wheel track according to the following scheme (see an example in [Figure 5](#)).
- c) For sound absorption, texture, and geometrical compliance, the first point shall be chosen randomly on each side in the vicinity of the line PP' and the subsequent measurements shall be performed at 5 m intervals not on the same axis of the centre line to cover the whole track.
- d) After the construction, take a total of four cores, preferably at 10 m intervals outside the wheel tracks on the driving lane run-up section, and measure the sieving curve from these samples.

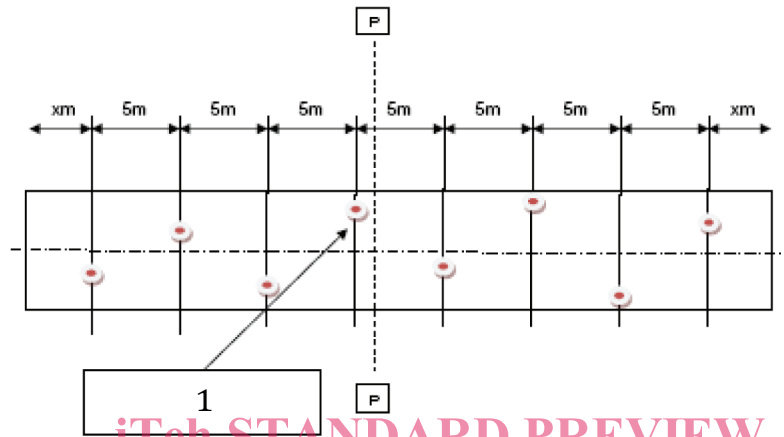

iTeh STANDARD PREVIEW
(standards.iteh.ai)

Key

1 first point randomly chosen

ISO 10844:2014

[https://standards.iteh.ai/catalog/standards/sist/f760722a-e887-4c62-8994-](https://standards.iteh.ai/catalog/standards/sist/f760722a-e887-4c62-8994-7f0e9e44e31c/iso-10844-2014)

[7f0e9e44e31c/iso-10844-2014](https://standards.iteh.ai/catalog/standards/sist/f760722a-e887-4c62-8994-7f0e9e44e31c/iso-10844-2014)

Figure 5 — Measurement positions on test track, example for $l = 40$ m

For checking the surface properties of the propagation area, take at least two measurements randomly chosen on each side.

In addition, sound absorption of the propagation area shall be measured at both sides of the drive lane, between the microphone location and the centre of drive lane in the vicinity of the line PP'.

Table 2 — Periodicity for checking the requirements during acceptance and periodical checking

Requirements for the track		For acceptance		For periodical checking	
		Drive lane	Propagation area	Drive lane	Propagation area
Slope	Gradient	× (0,5 %)	N.A.	N.A.	N.A.
	Cross fall	× (1 %)	× (2 %)	N.A.	N.A.
Longitudinal irregularity		× (≤2 mm)	× (≤20 mm) randomly	× (≤5 mm) 2 years ^a	N.A.
Transverse irregularity		× (≤3 mm)		× (≤5 mm) 2 years ^a	N.A.

Table 2 (continued)

Requirements for the track	For acceptance		For periodical checking	
	Drive lane	Propagation area	Drive lane	Propagation area
Texture	× MPD 0,5 mm ± 0,2 mm	N.A.	× MPD 0,5 mm ± 0,2 mm 2 years ^a	N.A.
Absorption	× (8 % maximum)	× (10 % maximum)	× (8 % maximum) 4 years ^a	N.A.
Grading curve	×	N.A.	N.A.	N.A.
×	to be checked			
N.A.	not applicable			
a	Periodicity.			

4.5 Homogeneity of surface properties

In order to ensure that the properties of the drive lane and the properties of the propagation area are homogeneous, the average of all positions and 80 % of the samples shall meet the requirements with respect to:

- acoustic absorption;
- surface texture;
- geometrical compliance.

iTeh STANDARD PREVIEW
(standards.iteh.ai)
ISO 10844:2014
<https://standards.iteh.ai/catalog/standards/sist/f760722a-e887-4c62-8994-7f9e9e44e31c/iso-10844-2014>

4.6 Stability with time and maintenance

The test track is a test instrument and shall be protected from damage and be taken care of. The test track should be used only for noise measurements.

Loose debris or dust which could significantly reduce the texture depth shall be removed from the surface.

Sealing of cracks is acceptable as long as acoustical performances (according to 4.2 and 4.3) of the test track are not affected.

See Annex B for recommendations.

4.7 Break-in of the test track

The texture and absorption characteristics shall be checked not earlier than 4 weeks after the construction or 1 000 passes after the construction.

If the surface is exclusively used for testing heavy vehicles (M2 above 3,5 t, M3, N2, and N3), this break-in period is not necessary.

5 Measurement methods and data processing

5.1 Irregularity measurement methods

The irregularity of the drive lane shall be determined according to EN 13036-7 using a straightedge consisting of a beam of 3,0 m in length and a wedge with 1-mm steps on the oblique side.