



SLOVENSKI STANDARD
SIST EN 13880-7:2019

01-julij-2019

Nadomešča:
SIST EN 13880-7:2004

Toplo nanosljive tesnilne mase za stike - 7. del: Preskušanje funkcionalnosti tesnilne mase za stike

Hot applied joint sealants - Part 7: Function testing of joint sealants

Heiß verarbeitbare Fugenmassen - Teil 7: Funktionsprüfung von Fugenmassen

iTeh STANDARD PREVIEW

(applied hot)
Produits de scellement de joints appliqués à chaud - Partie 7 : Test fonctionnel sur produits de scellement de joints

[SIST EN 13880-7:2019](https://standards.iteh.ai/catalog/standards/sist/5aabb597-289c-4289-b90a-a01504650640/sist-en-13880-7-2019)

Ta slovenski standard je istoveten z: EN 13880-7:2019

ICS:

91.100.50	Veziva. Tesnilni materiali	Binders. Sealing materials
93.080.20	Materiali za gradnjo cest	Road construction materials

SIST EN 13880-7:2019

en,fr,de

iTeh STANDARD PREVIEW
(standards.iteh.ai)

SIST EN 13880-7:2019

<https://standards.iteh.ai/catalog/standards/sist/5aabb597-289c-4289-b90a-a6f364b50640/sist-en-13880-7-2019>

EUROPEAN STANDARD

EN 13880-7

NORME EUROPÉENNE

EUROPÄISCHE NORM

April 2019

ICS 93.080.20

Supersedes EN 13880-7:2003

English Version

Hot applied joint sealants - Part 7: Function testing of joint sealants

Produits de scellement de joints appliqués à chaud -
Partie 7 : Test fonctionnel sur produits de scellement
de joints

Heiß verarbeitbare Fugenmassen - Teil 7:
Funktionsprüfung von Fugenmassen

This European Standard was approved by CEN on 25 February 2019.

CEN members are bound to comply with the CEN/CENELEC Internal Regulations which stipulate the conditions for giving this European Standard the status of a national standard without any alteration. Up-to-date lists and bibliographical references concerning such national standards may be obtained on application to the CEN-CENELEC Management Centre or to any CEN member.

This European Standard exists in three official versions (English, French, German). A version in any other language made by translation under the responsibility of a CEN member into its own language and notified to the CEN-CENELEC Management Centre has the same status as the official versions.

CEN members are the national standards bodies of Austria, Belgium, Bulgaria, Croatia, Cyprus, Czech Republic, Denmark, Estonia, Finland, Former Yugoslav Republic of Macedonia, France, Germany, Greece, Hungary, Iceland, Ireland, Italy, Latvia, Lithuania, Luxembourg, Malta, Netherlands, Norway, Poland, Portugal, Romania, Serbia, Slovakia, Slovenia, Spain, Sweden, Switzerland, Turkey and United Kingdom.



EUROPEAN COMMITTEE FOR STANDARDIZATION
COMITÉ EUROPÉEN DE NORMALISATION
EUROPÄISCHES KOMITEE FÜR NORMUNG

CEN-CENELEC Management Centre: Rue de la Science 23, B-1040 Brussels

Contents		Page
European foreword.....		3
1	Scope.....	5
2	Normative references.....	5
3	Terms and definitions	5
4	Principle	5
5	Apparatus.....	6
6	Preparation and conditioning of test specimens.....	6
7	Test procedure	8
8	Calculation and expression of results.....	9
8.1	Maximum tension.....	9
8.2	Failures	10
9	Test report.....	10

iTeh STANDARD PREVIEW
(standards.iteh.ai)

SIST EN 13880-7:2019

<https://standards.iteh.ai/catalog/standards/sist/5aabb597-289c-4289-b90a-a6f364b50640/sist-en-13880-7-2019>

European foreword

This document (EN 13880-7:2019) has been prepared by Technical Committee CEN/TC 227 “Road materials”, the secretariat of which is held by BSI.

This European Standard shall be given the status of a national standard, either by publication of an identical text or by endorsement, at the latest by October 2019, and conflicting national standards shall be withdrawn at the latest by October 2019.

Attention is drawn to the possibility that some of the elements of this document may be the subject of patent rights. CEN shall not be held responsible for identifying any or all such patent rights.

This document supersedes EN 13880-7:2003.

This European Standard is one of a series of standards as listed below:

- EN 13880-1, *Hot applied joint sealants — Part 1: Test method for the determination of density at 25 °C*
- EN 13880-2, *Hot applied joint sealants — Part 2: Test method for the determination of cone penetration at 25°C*
- EN 13880-3, *Hot applied joint sealants — Part 3: Test method for the determination of penetration and recovery (resilience)*
- EN 13880-4, *Hot applied joint sealants — Part 4: Test method for the determination of heat resistance — Change in penetration value*
- EN 13880-5, *Hot applied joint sealants — Part 5: Test method for the determination of flow resistance*
- EN 13880-6, *Hot applied joint sealants — Part 6: Method for the preparation of samples for testing*
- EN 13880-7, *Hot applied joint sealants — Part 7: Function testing of joint sealants*
- EN 13880-8, *Hot applied joint sealants — Part 8: Test method for the determination of the change in weight of fuel resistance joint sealants after fuel immersion*
- EN 13880-9, *Hot applied joint sealants — Part 9: Test method for the determination of compatibility with asphalt pavements*
- EN 13880-10, *Hot applied joint sealants — Part 10: Test method for the determination of adhesion and cohesion following continuous extension and compression*
- EN 13880-11, *Hot applied joint sealants — Part 11: Test method for the preparation of asphalt test blocks used in the function test and for the determination of compatibility with asphalt pavements*
- EN 13880-12, *Hot applied joint sealants — Part 12: Test method for the manufacture of concrete test blocks for bond testing (recipe methods)*
- EN 13880-13, *Hot applied joint sealants — Part 13: Test method for the determination of the discontinuous extension (adherence test)*

EN 13880-7:2019 (E)

The following significant changes have been introduced in this edition:

- Accuracy requirements of apparatus have been added.
- Measurement device to measure depth of failures has been added.
- The conditioning procedure has been removed.
- Procedure for sealant type N2 and F2 has been added.

According to the CEN-CENELEC Internal Regulations, the national standards organisations of the following countries are bound to implement this European Standard: Austria, Belgium, Bulgaria, Croatia, Cyprus, Czech Republic, Denmark, Estonia, Finland, Former Yugoslav Republic of Macedonia, France, Germany, Greece, Hungary, Iceland, Ireland, Italy, Latvia, Lithuania, Luxembourg, Malta, Netherlands, Norway, Poland, Portugal, Romania, Serbia, Slovakia, Slovenia, Spain, Sweden, Switzerland, Turkey and the United Kingdom.

iTeh STANDARD PREVIEW
(standards.iteh.ai)

SIST EN 13880-7:2019

<https://standards.iteh.ai/catalog/standards/sist/5aabb597-289c-4289-b90a-a6f364b50640/sist-en-13880-7-2019>

1 Scope

This document describes a function test for hot-applied joint sealants intended to be used in areas where the joints are subjected to combined conditions of temperature $\leq -20\text{ °C}$ and crack joint movement $\leq 35\%$ in construction joints as well as in spontaneously formed cracks in road and airfield pavements.

2 Normative references

The following documents are referred to in the text in such a way that some or all of their content constitutes requirements of this document. For dated references, only the edition cited applies. For undated references, the latest edition of the referenced document (including any amendments) applies.

EN 13880-6, *Hot applied joint sealants - Part 6: Method for the preparation of samples for testing*

EN 13880-11, *Hot applied joint sealants - Part 11: Test method for the preparation of asphalt test blocks used in the function test and for the determination of compatibility with asphalt pavements*

EN 13880-12, *Hot applied joint sealants - Part 12: Test method for the manufacture of concrete test blocks for bond testing (recipe methods)*

EN 14188-1, *Joint fillers and sealants - Part 1: Specifications for hot applied sealants*

ISO 5893, *Rubber and plastics test equipment — Tensile, flexural and compression types (constant rate of traverse) — Specification*

3 Terms and definitions

For the purposes of this document, the terms and definitions given in EN 14188-1 and the following apply.

ISO and IEC maintain terminological databases for use in standardization at the following addresses:

- IEC Electropedia: available at <http://www.electropedia.org/>
- ISO Online browsing platform: available at <http://www.iso.org/obp>

3.1

adhesion failures

part of the surface area of the test blocks from which the hot applied joint sealant has completely separated

3.2

cohesion failures

cracks in the superficial areas on the faces of the hot applied joint sealant

4 Principle

This method is intended to serve as an accelerated test for the assessment of damage to hot applied sealants resulting from fluctuating temperatures, water-spraying and simultaneous dynamic loads.

EN 13880-7:2019 (E)

5 Apparatus

5.1 Tensile test rig, which allows the test specimens to be inserted into holding clamps, conveniently and without disturbing the test specimens before, during or after removal. The test rig shall be capable of testing one specimen or a number of test specimens simultaneously and shall not be significantly affected by the failure of one or more test specimens.

The testing rig shall have the following characteristics:

- be motor driven through positive drives without slip or significant backlash, so that cycles of extension and compression are carried out steadily and automatically;
- be capable of moving the test specimens smoothly and linearly, so that their alignment is maintained at all times without subjecting them to torsion, bending, shock, or significant vibration;
- under the specified conditions in Clause 8;
- be capable of measuring and recording the changes in force;
- The accuracy of the test rig shall be class 2A according to ISO 5893.

Testing may also be carried out at differing ratios of temperature, deformation and movement in accordance with the sealant manufacturer's recommendations provided that the criteria are within the capabilities of the test rig described above.

5.2 Climate chamber, capable of reducing or raising the temperature of a full complement of test specimens to the specified temperature throughout the period of examination.

The chamber shall be fitted with a time controlled device to allow the specimen to be subjected to water spraying for 20 % of the total conditioning time at the appropriate temperature as provided for in Clause 7.

5.3 Temperature indicator, consisting of an electronic device capable of measuring temperatures in the range of -30 °C to $+30\text{ °C}$ to an accuracy of $\pm 1\text{ °C}$;

5.4 Depth gauge, device to measure depth of failures to the nearest 1 mm.

6 Preparation and conditioning of test specimens

6.1 Prepare the test specimens according to EN 13880-6.

6.2 Concrete test blocks in accordance with EN 13880-12 and asphalt test blocks in accordance with EN 13880-11 shall be used. The dimensions of the test blocks are (75 ± 1) mm length, $(25,0 \pm 0,5)$ mm width and $(12,0 \pm 0,5)$ mm height. The concrete test blocks shall have a moisture content within the limits of $(5,5 \pm 1,5)$ %.

6.3 Use a suitable mould to place two test blocks exactly opposite each other for a joint width of $(12,0 \pm 0,5)$ mm.

6.4 If a primer is used, apply it to the sawn test faces of the test blocks in accordance with the manufacturer's instructions.

6.5 Place a top-mask on the mould so that the joint can be overfilled when the test sample is poured into it.

6.6 Any adhering of the test sample to the borders of the joint shall be avoided.

6.7 Allow the test specimens to cool at laboratory temperature for 2 h after which remove the excess test sample using a heated knife so that the test specimens are flush with the surface of the test blocks.

6.8 Three test specimens shall be prepared for each test. The test specimens shall be as described in Figures 1 and 2.

Dimensions in millimetres

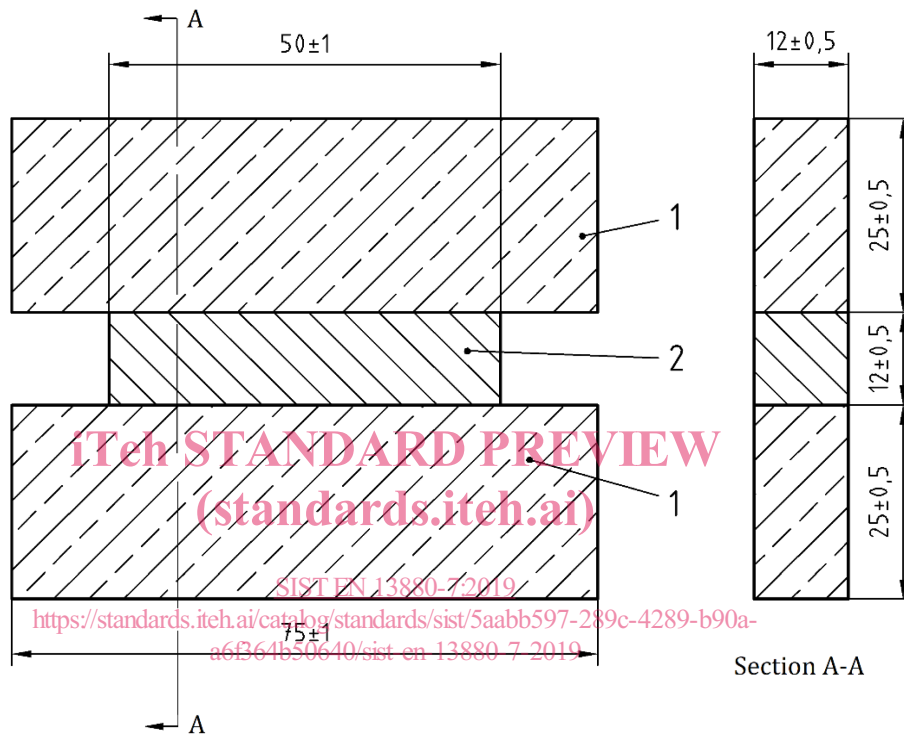

Key

- 1 concrete test blocks according to EN 13880-12
- 2 hot applied joint sealant

Figure 1 — Test specimen of concrete test blocks