



**SLOVENSKI STANDARD**  
**oSIST prEN ISO 22653:2018**  
**01-julij-2018**

---

**Obutev - Preskusne metode za podloge in vrhnje vložke - Statično trenje (ISO 22653:2003)**

Footwear - Test methods for lining and insoles - Static friction (ISO 22653:2003)

Schuhe - Prüfverfahren für Futter und Decksohlen - Haftreibung (ISO 22653:2003)

Chaussures - Méthodes d'essai pour la doublure et pour la première de propreté - Frottement statique (ISO 22653:2003)

**Ta slovenski standard je istoveten z: prEN ISO 22653**

---

**ICS:**

61.060          Obuvala          Footwear

**oSIST prEN ISO 22653:2018**          **en,fr,de**



# INTERNATIONAL STANDARD

**ISO**  
**22653**

First edition  
2003-12-01

---

---

## Footwear — Test methods for lining and insocks — Static friction

*Chaussures — Méthodes d'essai pour la doublure et pour la première  
de propreté — Frottement statique*

iTeh STANDARD PREVIEW  
(standards.iteh.ai)

SIST EN ISO 22653:2018

<https://standards.iteh.ai/catalog/standards/sist/b0c238c4-9419-435d-b939-33d83c37a077/sist-en-iso-22653-2018>



Reference number  
ISO 22653:2003(E)

© ISO 2003

**ISO 22653:2003(E)****PDF disclaimer**

This PDF file may contain embedded typefaces. In accordance with Adobe's licensing policy, this file may be printed or viewed but shall not be edited unless the typefaces which are embedded are licensed to and installed on the computer performing the editing. In downloading this file, parties accept therein the responsibility of not infringing Adobe's licensing policy. The ISO Central Secretariat accepts no liability in this area.

Adobe is a trademark of Adobe Systems Incorporated.

Details of the software products used to create this PDF file can be found in the General Info relative to the file; the PDF-creation parameters were optimized for printing. Every care has been taken to ensure that the file is suitable for use by ISO member bodies. In the unlikely event that a problem relating to it is found, please inform the Central Secretariat at the address given below.

# iTeh STANDARD PREVIEW

## (standards.iteh.ai)

SIST EN ISO 22653:2018

<https://standards.iteh.ai/catalog/standards/sist/b0c238c4-9419-435d-b939-33d83c37a077/sist-en-iso-22653-2018>

© ISO 2003

All rights reserved. Unless otherwise specified, no part of this publication may be reproduced or utilized in any form or by any means, electronic or mechanical, including photocopying and microfilm, without permission in writing from either ISO at the address below or ISO's member body in the country of the requester.

ISO copyright office  
Case postale 56 • CH-1211 Geneva 20  
Tel. + 41 22 749 01 11  
Fax + 41 22 749 09 47  
E-mail [copyright@iso.org](mailto:copyright@iso.org)  
Web [www.iso.org](http://www.iso.org)

Published in Switzerland

## Foreword

ISO (the International Organization for Standardization) is a worldwide federation of national standards bodies (ISO member bodies). The work of preparing International Standards is normally carried out through ISO technical committees. Each member body interested in a subject for which a technical committee has been established has the right to be represented on that committee. International organizations, governmental and non-governmental, in liaison with ISO, also take part in the work. ISO collaborates closely with the International Electrotechnical Commission (IEC) on all matters of electrotechnical standardization.

International Standards are drafted in accordance with the rules given in the ISO/IEC Directives, Part 2.

The main task of technical committees is to prepare International Standards. Draft International Standards adopted by the technical committees are circulated to the member bodies for voting. Publication as an International Standard requires approval by at least 75 % of the member bodies casting a vote.

Attention is drawn to the possibility that some of the elements of this document may be the subject of patent rights. ISO shall not be held responsible for identifying any or all such patent rights.

ISO 22653 was prepared by CEN (as EN 12826:2000) and was adopted, under a special “fast-track procedure”, by Technical Committee ISO/TC 216, *Footwear*, in parallel with its approval by the ISO member bodies.

For the purposes of international standardization, a list of corresponding International and European Standards for which equivalents are not given in EN 12826 has been added as Annex ZZ.

[SIST EN ISO 22653:2018](https://standards.iteh.ai/catalog/standards/sist/b0c238c4-9419-435d-b939-33d83c37a077/sist-en-iso-22653-2018)

<https://standards.iteh.ai/catalog/standards/sist/b0c238c4-9419-435d-b939-33d83c37a077/sist-en-iso-22653-2018>

**ISO 22653:2003(E)**

Page 2  
EN 12826:2000

**Contents**

|                                                                                                                                                         | Page |
|---------------------------------------------------------------------------------------------------------------------------------------------------------|------|
| Foreword .....                                                                                                                                          | 3    |
| 1 Scope .....                                                                                                                                           | 4    |
| 2 Normative references .....                                                                                                                            | 4    |
| 3 Definitions .....                                                                                                                                     | 4    |
| 4 Apparatus and material .....                                                                                                                          | 4    |
| 5 Sampling and conditioning .....                                                                                                                       | 8    |
| 6 Test method .....                                                                                                                                     | 9    |
| 7 Expression of results .....                                                                                                                           | 11   |
| 8 Test report .....                                                                                                                                     | 17   |
| Annex A (informative) Examples of autographic traces of friction tests on coated fabrics and determination of the variability of kinetic friction ..... | 18   |

## Foreword

This European Standard has been prepared by Technical Committee CEN/TC 309 "Footwear", the secretariat of which is held by AENOR.

This European Standard shall be given the status of a national standard, either by publication of an identical text or by endorsement, at the latest by September 2000, and conflicting national standards shall be withdrawn at the latest by September 2000.

According to the CEN/CENELEC Internal Regulations, the national standards organizations of the following countries are bound to implement this European Standard: Austria, Belgium, Czech Republic, Denmark, Finland, France, Germany, Greece, Iceland, Ireland, Italy, Luxembourg, Netherlands, Norway, Portugal, Spain, Sweden, Switzerland and the United Kingdom.

iTeh STANDARD PREVIEW  
(standards.iteh.ai)

[SIST EN ISO 22653:2018](https://standards.iteh.ai/catalog/standards/sist/b0c238c4-9419-435d-b939-33d83c37a077/sist-en-iso-22653-2018)

<https://standards.iteh.ai/catalog/standards/sist/b0c238c4-9419-435d-b939-33d83c37a077/sist-en-iso-22653-2018>





## 1 Scope

This European standard specifies two methods of assessing the frictional properties of lining and insocks, irrespective of the material.

## 2 Normative references

This European Standard incorporates by dated or undated reference, provisions from other publications. These normative references are cited at the appropriate places in the text and the publications are listed hereafter. For dated references, subsequent amendments to or revisions of any of these publications apply to this European Standard only when incorporated in it by amendment or revision. For undated references the latest edition of the publication referred to applies.

EN 12222, *Footwear – Standard atmospheres for conditioning and testing of footwear and components for footwear.*

## 3 Definitions

For the purposes of this standard the following definitions apply:

### 3.1 coefficient of static friction ( $\mu_s$ )

the ratio of the force necessary to cause the tangential separation of two stationary surfaces to the perpendicular force acting upon the two surfaces

### 3.2 coefficient of kinetic friction ( $\mu_k$ )

the ratio of the force necessary to maintain a constant velocity between two surfaces in contact to the perpendicular force acting upon the two surfaces

### 3.3 kinetic angle of surface drag ( $D_k$ )

the angle of the inclined plane at which the test sled will slide down the inclined plane when sliding is initiated by a standard impulse

### 3.4 static angle of surface drag ( $D_s$ )

the angle of the inclined plane at which the test sled will slide down the inclined plane under its own mass and momentum

## 4 Apparatus and material

The following apparatus and material shall be used:

### 4.1 Method A

**4.1.1 A sled**, (150 mm  $\pm$  1 mm) long x (100 mm  $\pm$  1 mm) wide having a mass of 700 g  $\pm$  15 g to which a lining or insock test specimen is attached (see 5.1.1) and a test specimen support of cellular rubber, or plastics material, 3 mm thick and of medium apparent density. The surface of the sled is flat and smooth or polished. The edges of the sled do not contain any burrs or roughness.

When laid upon the horizontal bed of the test instrument the sliding surface of the sled is parallel with the horizontal bed, in full planar contact and without distortion.

**4.1.2 A driving mechanism**, to move the sled or horizontal bed in such a manner that the relative movement of one with the other can be maintained at a constant velocity of 800 mm/min  $\pm$  80 mm/min.

The drive mechanism is automatically disengaged or de-energized at the end of the test run (see 4.1.3).

**4.1.3 A flat bed** of rigid construction, having a smooth or polished surface to which the comparator material (see 5.1.2) is fixed in such a manner that the comparator material is not stretched more than a necessary minimum to remove wrinkles or other non-permanent distortions.

The flat bed is of a length to permit a relative surface travel during the test of approximately 400 mm and of a width to permit approximately 50 mm of clearance between the edge of the sled and any edge obstructions.

**4.1.4 A measuring device**, in the form of a strain gauge, with an associated autographic recording instrument to determine accurately the force necessary to initiate movement and the force necessary to maintain a constant velocity thereafter. The response time of the recording instrument is less than 0,25 s.

## 4.2 Method B

### 4.2.1 Instrument for the determination of static angle of surface drag ( $D_s$ )

**4.2.1.1 Rigid platform**, not less than 300 mm long and not less than 100 mm wide and hinged at one end to a baseboard provided with levelling screws. The rigid platform shall be provided with a spirit level and means for measuring the angle of inclination with an accuracy of  $\pm$  0,5°.

**4.2.1.2 A piece of woollen melton cloth<sup>1)</sup>**, measuring approximately 250 mm long and 100 mm wide with its length in the cross direction and fixed under slight tension to the platform (see 4.2.1.1)

NOTE The melton cloth should be covered when the apparatus is not in use. It should be replaced at intervals, or if contaminated.

**4.2.1.3 Specimen carrier**, made of metal, with dimensions as illustrated in figure 1. The total mass of the carrier including the clamping screw shall be adjusted to 300 g by balanced boring out of the upper section of the carrier.

---

<sup>1)</sup> Recommended physical characteristics of woven fabrics:

|                           |                                                        |
|---------------------------|--------------------------------------------------------|
| Fibre content:            | 90 % Wool, 10 % Cotton                                 |
| Weave:                    | 3/1 broken                                             |
| Finish and other details: | woollen spun                                           |
| Mass per unit area:       | min. 650 g/m <sup>2</sup>                              |
| Threads per unit length:  | warp: min. 14,6 per cm, weft: min. 11,0 per cm         |
| Breaking strength:        | warp: min. 355 N per 50 mm, weft: min. 325 N per 50 mm |
| Dimensional change:       | max. 2,0                                               |

Dimensions in millimetres

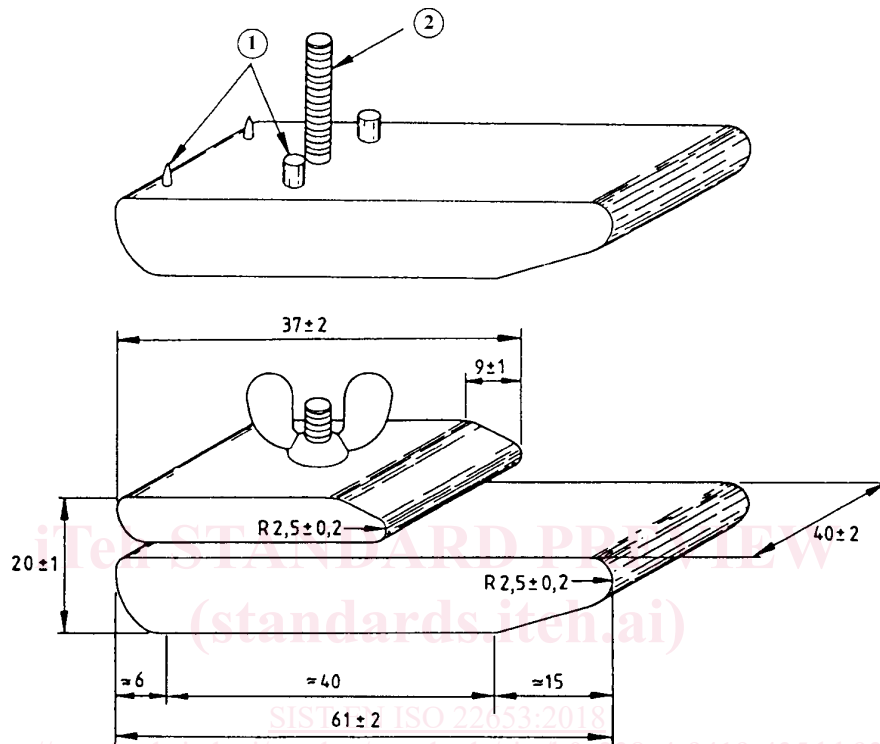
**Key**

- 1 Suggested arrangement only for locating pins and/or locating lugs
- 2 Thread locating and securing spindle for specimen carrier top part

**Figure 1 – Specimen holder for method B**

**4.2.1.4 Electric motor**, suitably geared to tilt the plane of the platform mechanically at a rate of  $15^\circ/\text{min} \pm 2^\circ/\text{min}$ .

**4.2.1.5 Microswitch** included in the circuit in series with the electric motor (4.2.1.4) and is positioned at the top end of the platform (4.2.1.1) so that the actuating lever of the switch may be depressed by the back edge of the specimen carrier (4.2.1.3) resting on the melton cloth. A suitable stop shall be provided such that the distance of travel of the specimen carrier between the stop and the contact breaking position of the switch is  $4,5 \text{ mm} \pm 0,5 \text{ mm}$ .

The force required to depress the actuating lever of the microswitch shall be between 40 mN and 80 mN.

A suitable apparatus is shown schematically in figure 2.