

ETSI TS 124 002 V17.0.0 (2022-05)



**Digital cellular telecommunications system (Phase 2+) (GSM);
Universal Mobile Telecommunications System (UMTS);
LTE;
5G;
GSM - UMTS Public Land Mobile Network (PLMN)
Access Reference Configuration
(3GPP TS 24.002 version 17.0.0 Release 17)**



Reference

RTS/TSGC-0124002vh00

Keywords

5G,GSM,LTE,UMTS

ETSI

650 Route des Lucioles
F-06921 Sophia Antipolis Cedex - FRANCE

Tel.: +33 4 92 94 42 00 Fax: +33 4 93 65 47 16

Siret N° 348 623 562 00017 - APE 7112B
Association à but non lucratif enregistrée à la
Sous-Préfecture de Grasse (06) N° w061004871

Important notice

The present document can be downloaded from:

<http://www.etsi.org/standards-search>

The present document may be made available in electronic versions and/or in print. The content of any electronic and/or print versions of the present document shall not be modified without the prior written authorization of ETSI. In case of any existing or perceived difference in contents between such versions and/or in print, the prevailing version of an ETSI deliverable is the one made publicly available in PDF format at www.etsi.org/deliver.

Users of the present document should be aware that the document may be subject to revision or change of status.

Information on the current status of this and other ETSI documents is available at

<https://portal.etsi.org/TB/ETSIDeliverableStatus.aspx>

If you find errors in the present document, please send your comment to one of the following services:

<https://portal.etsi.org/People/CommitteeSupportStaff.aspx>

If you find a security vulnerability in the present document, please report it through our

Coordinated Vulnerability Disclosure Program:

<https://www.etsi.org/standards/coordinated-vulnerability-disclosure>

Notice of disclaimer & limitation of liability

The information provided in the present deliverable is directed solely to professionals who have the appropriate degree of experience to understand and interpret its content in accordance with generally accepted engineering or other professional standard and applicable regulations.

No recommendation as to products and services or vendors is made or should be implied.

No representation or warranty is made that this deliverable is technically accurate or sufficient or conforms to any law and/or governmental rule and/or regulation and further, no representation or warranty is made of merchantability or fitness for any particular purpose or against infringement of intellectual property rights.

In no event shall ETSI be held liable for loss of profits or any other incidental or consequential damages.

Any software contained in this deliverable is provided "AS IS" with no warranties, express or implied, including but not limited to, the warranties of merchantability, fitness for a particular purpose and non-infringement of intellectual property rights and ETSI shall not be held liable in any event for any damages whatsoever (including, without limitation, damages for loss of profits, business interruption, loss of information, or any other pecuniary loss) arising out of or related to the use of or inability to use the software.

Copyright Notification

No part may be reproduced or utilized in any form or by any means, electronic or mechanical, including photocopying and microfilm except as authorized by written permission of ETSI.

The content of the PDF version shall not be modified without the written authorization of ETSI.

The copyright and the foregoing restriction extend to reproduction in all media.

© ETSI 2022.
All rights reserved.

Intellectual Property Rights

Essential patents

IPRs essential or potentially essential to normative deliverables may have been declared to ETSI. The declarations pertaining to these essential IPRs, if any, are publicly available for **ETSI members and non-members**, and can be found in ETSI SR 000 314: "*Intellectual Property Rights (IPRs); Essential, or potentially Essential, IPRs notified to ETSI in respect of ETSI standards*", which is available from the ETSI Secretariat. Latest updates are available on the ETSI Web server (<https://ipr.etsi.org/>).

Pursuant to the ETSI Directives including the ETSI IPR Policy, no investigation regarding the essentiality of IPRs, including IPR searches, has been carried out by ETSI. No guarantee can be given as to the existence of other IPRs not referenced in ETSI SR 000 314 (or the updates on the ETSI Web server) which are, or may be, or may become, essential to the present document.

Trademarks

The present document may include trademarks and/or tradenames which are asserted and/or registered by their owners. ETSI claims no ownership of these except for any which are indicated as being the property of ETSI, and conveys no right to use or reproduce any trademark and/or tradename. Mention of those trademarks in the present document does not constitute an endorsement by ETSI of products, services or organizations associated with those trademarks.

DECT™, **PLUGTESTS™**, **UMTS™** and the ETSI logo are trademarks of ETSI registered for the benefit of its Members. **3GPP™** and **LTE™** are trademarks of ETSI registered for the benefit of its Members and of the 3GPP Organizational Partners. **oneM2M™** logo is a trademark of ETSI registered for the benefit of its Members and of the oneM2M Partners. **GSM®** and the GSM logo are trademarks registered and owned by the GSM Association.

Legal Notice

(standards.iteh.ai)

This Technical Specification (TS) has been produced by ETSI 3rd Generation Partnership Project (3GPP).

The present document may refer to technical specifications or reports using their 3GPP identities. These shall be interpreted as being references to the corresponding ETSI deliverables.

The cross reference between 3GPP and ETSI identities can be found under <http://webapp.etsi.org/key/queryform.asp>.

Modal verbs terminology

In the present document "**shall**", "**shall not**", "**should**", "**should not**", "**may**", "**need not**", "**will**", "**will not**", "**can**" and "**cannot**" are to be interpreted as described in clause 3.2 of the [ETSI Drafting Rules](#) (Verbal forms for the expression of provisions).

"**must**" and "**must not**" are **NOT** allowed in ETSI deliverables except when used in direct citation.

Contents

Intellectual Property Rights	2
Legal Notice	2
Modal verbs terminology.....	2
Foreword.....	4
1 Scope	5
1.1 References	5
1.2 Abbreviations	6
2 General definitions	6
2.1 Reference Configurations.....	7
2.2 Functional Groups	7
2.3 Reference Points.....	7
2.4 Interface Points.....	7
2.5 Terminal Definitions	7
3 Reference Configuration	8
3.0 General	8
3.1 Mobile Termination (MT).....	9
3.2 Void.....	10
4 Physical Realisation	10
Annex A (informative): Change history	11
History	12

iTEH STANDARD
PREVIEW
(standards.iteh.ai)

[ETSI TS 124 002 V17.0.0 \(2022-05\)](https://standards.iteh.ai/catalog/standards/sist/0f189fa9-e1cd-4690-9ef2-e74817d69c73/etsi-ts-124-002-v17-0-0-2022-05)
<https://standards.iteh.ai/catalog/standards/sist/0f189fa9-e1cd-4690-9ef2-e74817d69c73/etsi-ts-124-002-v17-0-0-2022-05>

Foreword

This Technical Specification has been produced by the 3rd Generation Partnership Project (3GPP).

The contents of the present document are subject to continuing work within the TSG and may change following formal TSG approval. Should the TSG modify the contents of the present document, it will be re-released by the TSG with an identifying change of release date and an increase in version number as follows:

Version x.y.z

where:

- x the first digit:
 - 1 presented to TSG for information;
 - 2 presented to TSG for approval;
 - 3 or greater indicates TSG approved document under change control.
- y the second digit is incremented for all changes of substance, i.e. technical enhancements, corrections, updates, etc.
- z the third digit is incremented when editorial only changes have been incorporated in the document.

**iTeh STANDARD
PREVIEW
(standards.iteh.ai)**

[ETSI TS 124 002 V17.0.0 \(2022-05\)](https://standards.iteh.ai/catalog/standards/sist/0f189fa9-e1cd-4690-9ef2-e74817d69c73/etsi-ts-124-002-v17-0-0-2022-05)
[https://standards.iteh.ai/catalog/standards/sist/0f189fa9-
e1cd-4690-9ef2-e74817d69c73/etsi-ts-124-002-v17-0-
0-2022-05](https://standards.iteh.ai/catalog/standards/sist/0f189fa9-e1cd-4690-9ef2-e74817d69c73/etsi-ts-124-002-v17-0-0-2022-05)

1 Scope

The present document describes the reference configuration for access to a PLMN.

A user accesses a PLMN via a number of interfaces, including the MS-BS (in A/Gb mode and GERAN Iu mode), UE-UTRAN (in UTRAN Iu mode), UE-E-UTRAN, and UE-5G-AN interface. The purpose of this document is to indicate the possible access arrangements that may be used in conjunction with the MS-BS (in A/Gb mode and GERAN Iu mode), UE-UTRAN (in UTRAN Iu mode), UE-E-UTRAN, and UE-5G-AN interface.

1.1 References

The following documents contain provisions which, through reference in this text, constitute provisions of the present document.

- References are either specific (identified by date of publication, edition number, version number, etc.) or non-specific.
- For a specific reference, subsequent revisions do not apply.
- For a non-specific reference, the latest version applies. In the case of a reference to a 3GPP document (including a GSM document), a non-specific reference implicitly refers to the latest version of that document *in the same Release as the present document*.

[1]	Void.	iTeh STANDARD PREVIEW (standards.iteh.ai)
[2]	Void.	
[3]	Void.	
[4]	Void.	
[5]	Void.	
[6]	Void.	ETSI TS 124 002 V17.0.0 (2022-05) https://standards.iteh.ai/catalog/standards/sist/0f189fa9- e1cd-4690-9ef2-e74817d69c73/etsi-ts-124-002-v17-0- 0-2022-05
[7]	Void.	
[8]	Void.	
[9]	Void.	
[10]	Void.	
[11]	Void.	
[12]	Void.	
[13]	Void.	
[14]	3GPP TS 44.021: "Rate adaption on the Mobile Station - Base Station System (MS - BSS) interface".	
[15]	Void.	
[16]	Void.	
[17]	Void.	
[18]	Void.	
[19]	Void.	
[20]	Void.	
[21]	Void.	

- [22] Void.
- [23] Void.
- [24] Void.
- [25] Void.
- [26] Void.
- [27] Void.
- [28] Void.
- [29] Void.
- [30] Void.
- [31] Void.
- [32] Void.
- [33] 3GPP TS 27.001: "General on Terminal Adaptation Functions (TAF) for Mobile Stations (MS)".
- [34] 3GPP TS 27.002: "Terminal Adaptation Functions (TAF) for services using asynchronous bearer capabilities".
- [35] 3GPP TS 27.003: "Terminal Adaptation Functions (TAF) for services using synchronous bearer capabilities".
- [36] Void.
- [37] Void.
- [38] Void.
- [39] 3GPP TR 21.905: "Vocabulary for 3GPP Specifications." <https://standards.iteh.ai/catalog/standards/sist/0f189fa9-e1cd-4690-9ef2-e74817d69c73/etsi-ts-124-002-v17-0-0-2022-05>
- [40] Void.
- [41] 3GPP TS 25.322: "Radio Link Control (RLC) Protocol Specification".
- [42] ITU-T Recommendation V.24 (1996): "List of definitions for interchange circuits between data terminal equipment (DTE) and data circuit-terminating equipment (DCE)".
- [43] ITU-T Recommendation V.28 (1993): "Electrical characteristics for unbalanced double-current interchange circuits".
- [44] Infrared Data Association IrDA: "IrPHY Physical layer signalling standard".
- [45] Personal Computer Memory Card Association: "PCMCIA 2.1 or PC-Card 3.0 electrical specification or later revisions".
- [46] Void.

1.2 Abbreviations

Abbreviations used in the present document are listed in 3GPP TR 21.905 [39].

2 General definitions

The following definitions 2.1-2.3 are based on those used for ISDN.

2.1 Reference Configurations

Reference Configurations are conceptual configurations useful in identifying access arrangements to a network. Two concepts are used in defining reference configurations:

reference points and functional groups.

2.2 Functional Groups

Functional Groups are sets of functions which may be needed in network access arrangements. In a particular access arrangement, specific functions in a functional group may or may not be present. Specific functions in a functional group may be performed in one or more pieces of equipment.

2.3 Reference Points

Reference Points are the conceptual points dividing functional groups. In a specific access arrangement, a reference point may correspond to a physical interface between pieces of equipment, or there may not be any physical interface corresponding to the reference point.

2.4 Interface Points

Interface Points are reference points within a PLMN at which a 3GPP specified interface is always identified.

2.5 Terminal Definitions

The term 'mobile station' (MS) in the present document is synonymous with the term 'user equipment' (UE) in 3G terminology as defined in 3GPP TR 21.905 [39].

The term 'TE2' in the present document is synonymous with the term 'TE' in 3G terminology as defined in 3GPP TR 21.905 [39].

The term 'MT2' in the present document is synonymous with the term 'MT' in 3G terminology as defined in 3GPP TR 21.905 [39].

3 Reference Configuration

3.0 General

The reference configuration for PLMN (in A/Gb mode and GERAN Iu mode) access interfaces is shown in figure 1.

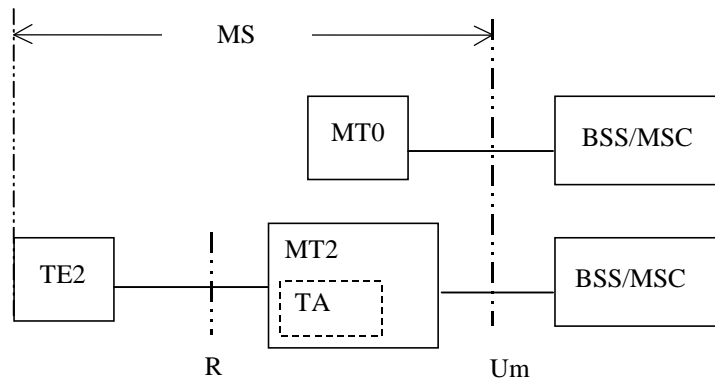

- ⊕ : reference point.
- TE2: V-type terminal.
- TA: Terminal Adaptor.
- GERAN: GSM/EDGE Radio Access Network.
- CN: Core Network.

**iTeh STANDARD
PREVIEW
(standards.iteh.ai)**

Figure 1: PLMN Access Reference Configuration (in A/Gb mode and GERAN Iu mode)

There are two types of MT:

- MT0 includes functions belonging to the functional group MT, with support of no terminal interfaces.
- MT2 includes functions belonging to the functional group MT, and with an interface that complies with the 3GPP TS 27.00z series Terminal Adaptation Function specifications [33], [34], [35]. Accordingly, the interchange circuit mapping at the MT2 to TE interface shall comply with the ITU-T V.24 [42] recommendation; while the physical implementation shall conform either to the ITU-T V.28 [43], or to the IrDA IrPHY Physical signalling standard specification [44], or to the PCMCIA 2.1 [45], or to the PC-Card 3.0 [45], electrical specification or to later revisions.

The MT plus any TE constitutes the Mobile Station, MS.

The terminal equipment functional groups TE2 and TA are conceptually the same functional groups as those in the ISDN.

The reference configuration for PLMN (Iu mode) access interfaces is shown in figure 2.

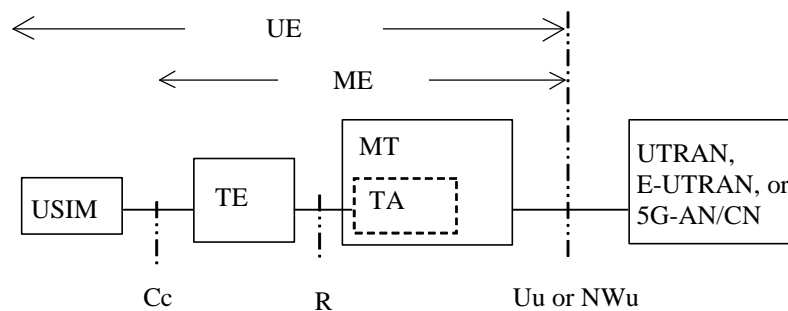

- ⊕ : reference point.
- TA: Terminal Adaptor.
- MT: Mobile Termination.
- ME: Mobile Equipment.
- UE: User Equipment
- UTRAN: UMTS Radio Access Network.
- E-UTRAN: Evolved UMTS Radio Access Network.
- CN: Core Network.
- 5G-AN: 5G Access Network.

Figure 2: PLMN Access Reference Configuration (UTRAN lu mode, E-UTRAN, or 5G-AN)

There is no reference point identified for the TA Function. The TA Function is considered as a part of the Mobile Termination and with an interface that complies with the 3GPP TS 27.00z series Terminal Adaptation Function specifications [33], [34], [35].

3.1 Mobile Termination (MT)

The MT performs the following functions, which performs the following functions:

- radio transmission termination;
- radio transmission channel management;
- terminal capabilities, including presentation of a man-machine interface to a user;
- speech encoding/decoding;
- error protection for all information sent across the radio path. This includes FEC (forward error correction) and, for signalling and user data (except for transparent data services), ARQ (automatic request for retransmission);
- flow control of signalling and mapping of user signalling to/from PLMN access signalling;
- flow control of user data (except for transparent data services) and mapping of flow control for asynchronous transparent data services;
- rate adaptation of user data (see 3GPP TS 44.021[14]) and data formatting for the transmission SAP (3GPP TS 25.322 [41]);
- multiple terminal support;
- mobility management.