INTERNATIONAL STANDARD



1817

INTERNATIONAL ORGANIZATION FOR STANDARDIZATION • МЕЖДУНАРОДНАЯ ОРГАНИЗАЦИЯ ПО СТАНДАРТИЗАЦИИ • ORGANISATION INTERNATIONALE DE NORMALISATION

Vulcanized rubbers — Resistance to liquids — Methods of test

Caoutchoucs vulcanisés — Résistance aux liquides — Méthodes d'essai

First edition — 1975-10-15

ITeH STANDARD PREVIEW
(standards.iteh.ai)

[ISO 1817:1975](#)

<https://standards.iteh.ai/catalog/standards/sist/de152fa3-5900-492a-9e22-5ed02717792a/iso-1817-1975>

UDC 678.4/.8.063 : 620.193

Ref. No. ISO 1817-1975 (E)

Descriptors : rubber, vulcanized rubber, chemical resistance, absorption, extraction, liquids, chemical reactions, performance tests.

Price based on 10 pages

FOREWORD

ISO (the International Organization for Standardization) is a worldwide federation of national standards institutes (ISO Member Bodies). The work of developing International Standards is carried out through ISO Technical Committees. Every Member Body interested in a subject for which a Technical Committee has been set up has the right to be represented on that Committee. International organizations, governmental and non-governmental, in liaison with ISO, also take part in the work.

Draft International Standards adopted by the Technical Committees are circulated to the Member Bodies for approval before their acceptance as International Standards by the ISO Council.

International Standard ISO 1817 was drawn up by Technical Committee ISO/TC 45, *Rubber and rubber products*. It was submitted directly to the ISO Council, in accordance with clause 6.12.1 of the Directives for the technical work of ISO.

iTeh STANDARD PREVIEW
(standards.itih.a)

ISO 1817:1975

This International Standard ~~cancels and replaces ISO Recommendation R 1817-1971~~, which had been approved by the Member Bodies of the following countries :

Australia	Hungary	Spain
Austria	India	Sri Lanka
Brazil	Israel	Sweden
Canada	Italy	Switzerland
Czechoslovakia	Netherlands	Turkey
Egypt, Arab Rep of	New Zealand	United Kingdom
France	Poland	U.S.A.
Germany	Romania	U.S.S.R.
Greece	South Africa, Rep. of	Yugoslavia

No Member Body had disapproved the Recommendation.

Vulcanized rubbers – Resistance to liquids – Methods of test

0 INTRODUCTION

The action of a liquid on a vulcanized rubber generally results in

- a) absorption of liquid by the rubber;
- b) extraction of soluble constituents from the rubber;
- c) chemical reaction with the rubber.

Usually a) is greater than b) so that the net result is an increase in volume, commonly termed "swelling". The absorption of liquid can profoundly alter the physical and chemical properties of the rubber such as tensile strength, extensibility and hardness, so that it is important to measure these properties of the rubber after treatment. The extraction of soluble constituents, especially plasticizers, can likewise alter the physical and chemical properties shown by the rubber after drying out the liquid (assuming this to be volatile) : physical tests on the rubber after immersion and drying are therefore required. The methods specified in this International Standard accordingly comprise determinations of

- change in volume or dimensions;
- soluble matter extracted;
- tensile stress-strain properties of the rubber after immersion;
- hardness of the rubber after immersion;
- tensile stress-strain properties of the rubber after drying out the immersion liquid;
- hardness after drying out the immersion liquid.

Although in some respects these tests may simulate service conditions closely, no direct correlation with service behaviour is implied; thus, the rubber giving the lowest change in volume is not necessarily the best in service. It is known, moreover, that the action of a liquid on rubber, especially at high temperatures, can be markedly affected by the presence of atmospheric oxygen. The tests specified hereafter, however, can provide valuable information on the suitability of a rubber for use with a given liquid, and, in particular, constitute a useful control when used comparatively for developing rubbers resistant to oils, fuels, or other liquids.

1 SCOPE AND FIELD OF APPLICATION

This International Standard specifies methods of test for evaluating the resistance of vulcanized rubbers to the action of liquids by measurement of properties of the rubbers before and after immersion in selected test liquids.

2 REFERENCES

ISO/R 37, *Determination of tensile stress-strain properties of vulcanized rubbers.*

ISO 48, *Vulcanized rubbers – Determination of hardness (Hardness between 30 and 85 IRHD).*

ISO/R 471, *Standard atmospheres for the conditioning and testing of rubber test pieces.*

3 TEST LIQUIDS

The selection of the test liquid depends on the purpose of the test.

3.1 When information is required on the *probable service behaviour* of a rubber in contact with a particular liquid, this liquid should preferably be used in the test. Commercial liquids, however, are not always constant in composition, and the test should therefore, whenever practicable, include a control rubber of known change-in-volume characteristics; abnormal results due to unsuspected variations in the commercial liquid will thus be made apparent. It may be found essential to set aside a bulk supply of the liquid for a particular series of tests.

Mineral oil based fluids and fuels are liable to vary appreciably in aromatic content even when supplied to a recognized specification. The aniline point of a mineral oil gives some indication of its aromatic content and helps to characterize the action of the oil on rubber, though aniline point alone is not sufficient to characterize a mineral oil; other things being equal, the lower the aniline point the more severe the action. The test report shall therefore include the relative density, refractive index, and the aniline point or aromatic content of the oil or fuel, if this is used as the immersion liquid. For the standardized mineral oils given in the annex, mineral oil raffinates are employed. Service liquids having similar fluid characteristics to oils Nos. 1 to 3 (see annex) will not necessarily have the same effect on rubber as the latter.

3.2 As commercial liquids may not have an entirely constant composition the test should, whenever possible, be made in well-defined chemical products, used alone or as mixtures. These shall be as representative as possible of the effect of the commercial products on the rubber. Examples of such chemicals are : toluene, alcohols, esters, cyclohexane, acetone.

3.3 For use in systems of *classification of vulcanized rubbers*, or for quality control, a standard immersion liquid shall be used; suitable liquids are recommended in the annex.

4 TIME-LAPSE BETWEEN VULCANIZATION AND TESTING

Unless otherwise specified for technical reasons, the following requirements for time-lapses shall be observed.

4.1 For all test purposes the minimum time-lapse between vulcanization and testing shall be 16 h.

4.2 For non-product tests the maximum time-lapse between vulcanization and testing shall be 4 weeks and for evaluations intended to be comparable with the tests, as far as possible, should be carried out after the same time-interval.

4.3 For product tests, whenever possible, the time-lapse between vulcanization and testing should not exceed 3 months. In other cases tests shall be made within 2 months of the date of receipt by the customer of the product.

5 CONDITIONING OF TEST PIECES

The pieces required for tests in the "as received" condition shall be conditioned for not less than 3 h in one of the standard laboratory atmospheres of ISO/R 471, namely : $20 \pm 2^\circ\text{C}$, $65 \pm 5\%$ relative humidity; $23 \pm 2^\circ\text{C}$, $50 \pm 5\%$ relative humidity; or $27 \pm 2^\circ\text{C}$, $60 \pm 5\%$ relative humidity. The same temperature shall be used throughout any one test or any series of tests intended to be comparable.

6 TEMPERATURE OF TEST IMMERSION

The test immersion should preferably be made at one or more of the following standard temperatures :

$-75 \pm 1^\circ\text{C}$	$50 \pm 1^\circ\text{C}$
$-55 \pm 1^\circ\text{C}$	$70 \pm 1^\circ\text{C}$
$-40 \pm 1^\circ\text{C}$	$85 \pm 1^\circ\text{C}$
$-25 \pm 1^\circ\text{C}$	$100 \pm 1^\circ\text{C}$
$-10 \pm 1^\circ\text{C}$	$125 \pm 1^\circ\text{C}$
$0 \pm 1^\circ\text{C}$	$150 \pm 2^\circ\text{C}$
$20 \pm 2^\circ\text{C}$	$175 \pm 2^\circ\text{C}$
$23 \pm 2^\circ\text{C}$	$200 \pm 2^\circ\text{C}$
$27 \pm 2^\circ\text{C}$	$225 \pm 2^\circ\text{C}$
$40 \pm 1^\circ\text{C}$	$250 \pm 2^\circ\text{C}$

Whenever possible, the temperature equal to or next more severe than that at which the rubber will be used should be selected. In other cases one of the standard laboratory temperatures given in clause 5 shall be adopted.

7 DURATION OF TEST IMMERSION

The dependence of the rate of penetration of liquids into rubbers on the particular rubber and liquid and on the temperature, precludes the adoption of one standard period of immersion. For acceptance purposes it is recommended that determination should be made and recorded after several periods of immersion, so as to indicate the change in volume or dimensions with time; the total period should, if possible, extend well beyond the point of maximum absorption. For control purposes it may not be necessary to reach maximum absorption; in such cases a single immersion period may suffice and one of the following periods shall then be used :

$$22 \pm 0,25 \text{ h}$$

$$70 \pm \begin{matrix} 2 \\ 0 \end{matrix} \text{ h}$$

$$7 \text{ days} \pm 2 \text{ h}$$

multiples of 7 days

In the volumetric method specified in 8.3, if the immersion period is insufficient to reach maximum absorption, the test piece shall be of substantially constant thickness (see note 2 to 8.3.2).

8 DETERMINATION OF CHANGE IN VOLUME OR CHANGE IN DIMENSIONS

8.1 Principle

The tests specified in 8.3 and 8.4 consist in immersing the test piece of rubber in a liquid for a given time, at a constant temperature, and determining the change in volume, or the changes in linear dimensions, respectively. In some instances the liquid may extract a proportion of the plasticizer or other soluble ingredient of the rubber, and this possibility must be borne in mind when interpreting the results.

The two methods described for studying resistance to liquid characteristics of rubber are as follows :

- gravimetric method;
- dimensional-measurement method.

Method a) is the more precise, and is the preferred method when it is required to know the change in volume due to immersion. Method b) is not suitable for absolute measurement but is useful for detecting grain (anisotropy) in the rubber, and it should be used when it is required to determine changes in linear dimensions, because these cannot always be calculated from the volume change owing to grain in the rubber.

8.2 Definitions

8.2.1 change in volume : The percentage change in volume which a test piece of given initial dimensions undergoes when immersed in, or exposed to the vapour of, a liquid for a given time and at a given temperature.

8.2.2 change in dimensions : The percentage change in linear dimensions which a test piece of given initial dimensions undergoes when immersed in, or exposed to the vapour of, a liquid for a given time and at a given temperature.

8.3 Gravimetric method

8.3.1 Apparatus

This is determined by the temperature of the test and the volatility of the immersion liquid. For tests at temperatures appreciably below the boiling point of the liquid, a stoppered glass bottle or tube shall be used, of such dimensions that the test pieces remain completely immersed in the specified volume of immersion liquid and are freely exposed at all surfaces without restraint. For tests at temperatures near the boiling point of the immersion liquid, the bottle or tube shall be fitted with a reflux condenser or other suitable means of minimizing evaporation of the test liquid.

8.3.2 Test piece

The test piece shall be 1 to 3 cm³* in volume and of uniform thickness of 2 ± 0,2 mm. Test pieces cut from sheet may be of any convenient rectangular shape but shall in no case be greater than 50 mm in length or breadth.

NOTES

- 1 Test pieces cut from finished products may be used. Test pieces from finished products thinner than 1,8 mm may be used; products thicker than 2,2 mm shall be buffed to a thickness of 2 ± 0,2 mm.
- 2 In tests where the maximum absorption is not reached, a smaller thickness tolerance of ± 0,1 mm shall be used as the percentage volume change during the early stages of absorption is inversely proportional to the test piece thickness.

8.3.3 Procedure

Use three test pieces. Weigh each test piece in air to the nearest milligram (m_1), and then reweigh each test piece in distilled water at the standard laboratory temperature (m_2) (see note 1 to 8.3.4), care being taken to ensure that all air bubbles are removed (see note 2 to 8.3.4).

Blot the test pieces dry with filter paper or a textile fabric that does not deposit lint and then place them, suitably separated, in a glass container with a volume of the

immersion liquid at least 15 times the combined volume of the test pieces and sufficient to keep them totally immersed. If the conditions of test do not necessitate a reflux condenser, the container shall be stoppered. The container shall be kept at the required temperature, and the rubber shielded from light during the test.

Only test pieces of the same vulcanizate shall be placed in any one container. If the density of the rubber is less than that of the liquid, means shall be provided for holding the test pieces completely below the surface of the liquid.

At the end of the immersion period, bring the test pieces, if necessary, to the standard laboratory temperature, preferably by quickly transferring them to a fresh portion of the immersion liquid at this temperature for a period of not less than 3 min and not more than 60 min. Remove surplus immersion liquid from the surfaces of each test piece (see note 3 to 8.3.4). Then immediately place the test piece in a tared and stoppered weighing bottle and determine its mass in air (m_3) to the nearest milligram. Remove the test piece from the bottle and immediately weigh in distilled water (m_4) at the standard laboratory temperature.

If the immersion liquid is appreciably volatile at room temperature, the time for each transference of the test piece, after removal from the immersion liquid, shall not exceed 30 s.

8.3.4 Expression of results

The percentage change in volume is given by the formula

$$\frac{(m_3 - m_4) - (m_1 - m_2)}{(m_1 - m_2)} \times 100$$

where

- m_1 is the initial mass of the rubber in air;
- m_2 is the initial apparent mass of the rubber in water;
- m_3 is the mass in air of the rubber after immersion;
- m_4 is the apparent mass in water of the rubber after immersion;

these masses being expressed in the same unit.

If the test is being continued, the test pieces shall at once be replaced in the immersion liquid and returned to the thermostatically controlled oven or bath.

Average the results for the three test pieces.

NOTES

- 1 The above procedure may not be suitable if the immersion liquid (other than water) is readily miscible with water or reacts with it.

* The term millilitre (ml) is commonly used as a special name for the cubic centimetre (cm³), in accordance with a decision of the Twelfth Conférence Générale des Poids et Mesures. The term millilitre is acceptable, in general, for references in International Standards to capacities of volumetric glassware and to liquid volumes.

For such a liquid, if it is not too viscous or volatile at room temperature, weighings m_2 and m_4 may be made in the immersion liquid instead of water and these values used in the formula for percentage change in volume given above; weighing m_4 shall in this case be made in a fresh portion of the immersion liquid.

If this is not practicable, the same procedure shall be used as for water displacement method except that the final weighing in water is omitted and the percentage change in volume calculated from the formula :

$$\frac{(m_3 - m_1)}{d(m_1 - m_2)} \times 100$$

where d is the relative density of the immersion liquid at the standard laboratory temperature; this formula may be only approximate if the immersion liquid is a mixture, because the relative density of the absorbed liquid may differ from that of the bulk. Also, the relative density of any matter extracted from the rubber may differ from that of the immersion liquid.

2 Formation of bubbles may be avoided by adding a trace of a surface-active material, for example detergent, to the water.

3 The method of removing the surplus liquid from the surface of the test piece will vary with the nature of the liquid. When mobile volatile liquids such as iso-octane and toluene are used, remove and quickly wipe the test piece with a filter paper or a piece of textile which does not deposit lint. Some difficulty may be experienced in completely removing viscous non-volatile oils by this method and it may be necessary to dip the test piece quickly in a suitable volatile liquid such as methanol and again quickly wipe with filter paper or a piece of textile which does not deposit lint.

8.3.5 Test report

The test report shall include the following information :

- a) the value(s) for the percentage change in volume, calculated according to 8.3.4, and the corresponding period(s) of immersion;
- b) temperature of test;
- c) description of the immersion liquid; in the case of mineral oils (other than oils Nos. 1, 2 and 3) this shall include the relative density, refractive index, and the aniline point or aromatic content;
- d) initial thickness and dimensions of the test piece;
- e) temperature of conditioning;
- f) note of any discoloration of the immersion liquid, or formation of sediment, at the conclusion of the test;
- g) note of the appearance of the test piece (cracks, delamination, etc.).

8.4 Dimensional-measurement method

8.4.1 Apparatus

The apparatus for immersion of the test pieces shall be as specified in 8.3.1.

The instrument for measuring the thickness of the test pieces shall consist of a micrometer dial-gauge of adequate accuracy firmly held in a rigid stand over a flat base-plate.

The gauge shall have a scale graduated in unit divisions of 0,01 mm. The plunger shall be fitted with a flat circular contact of area of approximately 100 mm² which shall be normal to the plunger and parallel to the base-plate. The dial-gauge shall operate to give a pressure on the rubber of approximately 2 kPa*.

8.4.2 Test piece

The test piece shall be rectangular, 50 mm long and 25 mm wide. The thickness shall be uniform, preferably $2 \pm 0,2$ mm. The sides shall be cut cleanly and at right angles to the top and bottom surfaces. When the direction of calender grain is known, the test piece shall be cut with its long axis parallel to the grain.

NOTE — Test pieces cut from finished products may be used. Test pieces from finished products thinner than 1,8 mm may be used; products thicker than 2,2 mm shall be buffed to a thickness of $2 \pm 0,2$ mm.

8.4.3 Procedure

Use three test pieces. Measure the initial length of each test piece along its centre line to the nearest 0,3 mm; measurements shall be taken along the top and bottom surfaces and the two results averaged. Similarly measure the initial width but taking four measurements in all, one top and one bottom measurement near each end of the test piece. Measure the initial thickness with the thickness gauge at four different points along the test piece and average the results. All measurements shall be made with the test piece at the standard laboratory temperature.

Then place the test pieces, suitably separated, in the glass container with a volume of the immersion liquid at least 15 times the combined volume of the test pieces, and sufficient to keep them totally immersed. If the conditions of the test do not necessitate a reflux condenser, the container shall be stoppered. The container shall be kept at the required temperature, and the rubber shielded from light during the test.

Only test pieces of the same vulcanizates shall be placed in any one container. If the density of the rubber is less than that of the liquid, means shall be provided for holding the test pieces completely below the surface of the liquid.

At the end of the immersion period, bring the test pieces, if necessary, to the standard laboratory temperature, preferably by quickly transferring them to a fresh portion of the immersion liquid at this temperature for a period of not less than 30 min and not more than 60 min. Remove surplus immersion liquid from the surface of the test pieces by wiping with filter paper or a textile fabric which does not deposit lint. Then remeasure the length, width and thickness of each test piece as specified above, with the test pieces at the standard laboratory temperature.

If the immersion liquid is appreciably volatile at room temperature, the measurements shall be completed within 1 min of removing the test piece from the immersion liquid.

* 1 kPa = 1 kN/m²

8.4.4 Expression of results

The percentage change in length is given by the formula :

$$\frac{L - L_0}{L_0} \times 100$$

where

L_0 is the initial length;

L is the length after immersion;

these lengths being expressed in the same unit.

Percentage change in width and percentage change in thickness shall be calculated in a similar manner.

If the test is being continued, the test pieces shall at once be replaced in the liquid and returned to the thermostatically controlled oven or bath.

Average the results for the three test pieces.

8.4.5 Test report

The test report shall include the following information :

- a) the values for percentage change in length, percentage change in width, and percentage change in thickness, calculated according to 8.4.4, and the corresponding periods of immersion;
- b) temperature of test;
- c) description of the immersion liquid; in the case of mineral oils (other than oils Nos. 1, 2 and 3) this shall include the relative density, refractive index, and the aniline point or aromatic content;
- d) initial thickness and dimensions of test piece;
- e) temperature of conditioning;
- f) note of any discoloration of the immersion liquid, or formation of sediment, at the conclusion of the test;
- g) note the appearance of the test piece (cracks, delamination, etc.).

by the wing nuts (D) mounted on the bolts (E). A hole of diameter approximately 30 mm may be made in the base-plate for the examination of the surface not in contact with the fluid. During the test the opening in the top of the chamber shall be closed by a close-fitting plug (F).

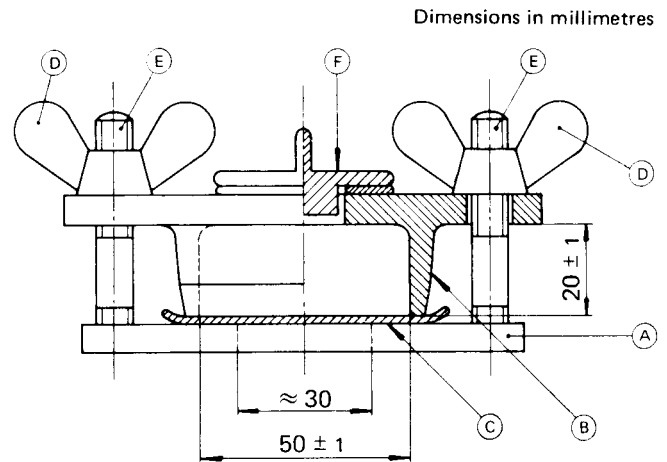

FIGURE

9.3 Test piece

The test piece shall consist of a disk of about 60 mm diameter and of the thickness of the material under test.

9.4 Procedure

Weigh the test piece in air to the nearest milligram (m_1). Then place the test piece in the apparatus as indicated in the figure. Fill the chamber of the apparatus with the test liquid to a depth of approximately 15 mm and insert the plug (F). Maintain the apparatus at the required temperature for the duration of the liquid contact.

At the end of the contact period, if necessary, bring the apparatus to the standard laboratory temperature. Then remove the test liquid and release the test piece. Any surplus liquid shall be removed from the surface of the test piece by wiping with filter paper or a textile fabric which does not deposit lint. Then determine the mass of the test piece to the nearest milligram (m_2) at the standard laboratory temperature.

If the test liquid is appreciably volatile at room temperature the measurement shall be completed within 2 min from the removal of the test liquid.

9.5 Expression of results

The change in mass per unit of surface area is given by the formula :

$$\frac{m_2 - m_1}{0,0020}$$

where

m_1 is the initial mass of the test piece;

m_2 is the final mass of the test piece;

9 TEST WITH LIQUID ON ONE SURFACE ONLY

9.1 Field of application

This test is applicable to relatively thin sheet materials (rubber-coated fabrics, diaphragms, etc.) that are exposed to the test liquid only on one surface. In consequence of possible absorption of fluid by the fabric, this method may be less accurate than the volumetric method specified in 8.3.

9.2 Apparatus

The apparatus shall be suitable for holding the standard test piece. Suitable apparatus is illustrated in the figure and comprises a base-plate (A) and an open-ended cylindrical chamber (B) which is held tightly against the test piece (C)

0,002 0 is the area in square metres of the circle 50 mm in diameter which corresponds to the area of contact of the test liquid on the test piece;

these masses being expressed in the same unit.

Average the results for at least three test pieces.

9.6 Test report

The test report shall include the following information :

- a) the value(s) for change in mass per unit of surface area calculated according to 9.5 and the corresponding periods of contact;
- b) temperature of test;
- c) description of the contacting liquid; in the case of mineral oils (other than oils Nos. 1, 2 and 3) this shall include the relative density, refractive index, and the aniline point or aromatic content;
- d) initial thickness of test piece;
- e) temperature of conditioning;
- f) note of any discoloration of the contacting liquid, or formation of sediment, at the conclusion of the test;
- g) note of the appearance of the test piece (cracking, delamination, etc.).

10 DETERMINATION OF SOLUBLE MATTER EXTRACTED BY LIQUID

10.1 Introduction

If the immersion liquid is readily volatile the amount of matter which it extracts from the rubber can be determined either

- a) by drying the treated rubber and comparing its mass with the mass before immersion, or
- b) by evaporating to dryness the liquid used in the test and weighing the non-volatile residue.

Both methods are liable to error; in method a) the rubber may have oxidized if air is present during immersion, especially if this is at high temperature; in method b) there may be some loss of volatile extracted material, especially plasticizers. Both methods are specified in this International Standard and the choice between them must depend on the nature of the rubber and the conditions of test.

It is difficult to define precisely what is meant by a "readily volatile" liquid, but it may be suggested that the procedures specified are not suitable for liquids less volatile than standard liquids A, B, C and D in the annex, i.e. for liquids boiling above 110 °C.

10.2 Test piece

The determination of soluble matter shall be made after the determination of change in volume or dimensions by either

of the methods specified in 8.3 and 8.4, using the test piece specified in 8.3.2 or 8.4.2.

10.3 Procedure

10.3.1 By weighing dried rubber

Dry the test piece to constant mass, after immersion, under a pressure of approximately 20 kPa at approximately 40 °C.

10.3.2 By evaporating the test liquid

Transfer the liquid in which the rubber has been immersed to a suitable vessel and wash the rubber with 25 cm³ of fresh liquid which shall then be transferred to the same vessel. Evaporate the liquid and dry the residue to constant mass under a pressure of approximately 20 kPa at approximately 40 °C.

Carry out a blank determination to estimate the solids content of a volume of the test liquid equal to that used for the immersion and washing.

10.4 Expression of results

The mass of matter extracted shall be taken as either :

— the difference between the original mass of the test piece and its mass after immersion and drying, if the procedure in 10.3.1 is followed, or

— the mass of the dried residue corrected for any blank determination on the test liquid, if the procedure in 10.3.2 is followed.

In either case the mass shall be expressed as a percentage of the original mass of the test piece.

10.5 Test report

The test report shall include the following information :

- a) the mass(es) of soluble matter extracted calculated according to 10.4 and the corresponding period(s) of immersion;
- b) the procedure employed;
- c) the temperature of immersion;
- d) description of the immersion liquid; in the case of mineral oils (other than oils Nos. 1, 2 and 3) this shall include the relative density, refractive index, and the aniline point or aromatic content;
- e) description of test pieces.

11 PHYSICAL PROPERTIES AFTER IMMERSION

11.1 Tensile stress-strain tests

11.1.1 Apparatus

11.1.1.1 Apparatus for immersion, as specified in 8.3.1.

11.1.1.2 Tensile test apparatus as specified in ISO/R 37.

11.1.2 Test piece

The test piece shall be either a ring or a dumb-bell as specified in ISO/R 37.

11.1.3 Procedure

Measure the cross-section of the test piece as in ISO/R 37. Immerse the test piece in the immersion liquid as specified in 8.3.3; the temperature shall be selected in accordance with the considerations given in clause 6 and the period of immersion should preferably be sufficient to reach the maximum absorption.

At the end of the immersion period, bring the test piece, if necessary, to the standard laboratory temperature, preferably by quickly transferring it to a fresh portion of the immersion liquid at this temperature for a period of not less than 30 min and not more than 60 min.

Remove any surplus test liquid from the surface of the test piece. The method of removing the surplus liquid will vary with the nature of the liquid. When mobile volatile liquids such as iso-octane and toluene are used, remove and quickly wipe the test piece with a filter paper or a piece of textile which does not deposit lint. Some difficulty may be experienced in completely removing viscous non-volatile oils by this method and it may be necessary to dip the test piece quickly in a suitable volatile liquid such as methanol and again quickly wipe with filter paper or a piece of textile which does not deposit lint. In the case of dumb-bells, gauge marks should be applied as in ISO/R 37. Carry out the tensile test at the standard laboratory temperature within an interval of 2 to 3 min after final removal from the immersion liquid. Tests shall be carried out on unimmersed test pieces for comparison.

11.1.4 Expression of results

Tensile strength shall be calculated per unit area of the original cross-section of the test piece before immersion and reported as the change expressed as a percentage of the value for unimmersed material.

Elongation at break shall be calculated as a percentage of gauge length for dumb-bell test pieces after immersion, or a percentage increase in the internal circumference of the ring test piece after immersion, and reported as the change expressed as a percentage of the value for unimmersed material.

Modulus shall be calculated on the original cross-section before immersion of the test piece and reported as the change expressed as a percentage of the value for unimmersed material (note, however, that the elongation at which modulus is measured is that of the rubber after immersion).

11.1.5 Test report

The test report shall include the following information :

- a) type of test piece;

- b) description of the immersion liquid; in the case of mineral oils (other than oils Nos. 1, 2 and 3) this shall include the relative density, refractive index, and the aniline point or aromatic content;

- c) period and temperature of immersion;

- d) percentage change in tensile strength;

- e) percentage change in elongation at break;

- f) percentage change in modulus at stated elongation;

- g) temperature at which tensile test is made.

11.2 Hardness tests

11.2.1 Apparatus

11.2.1.1 Apparatus for immersion as specified in 8.3.1.

11.2.1.2 Apparatus for measuring hardness as specified in ISO 48.

11.2.2 Test piece

The test piece shall be that for use with the micro-test specified in ISO 48.

11.2.3 Procedure

Measure the hardness of the test piece at a standard laboratory temperature as specified in ISO 48. Immerse the rubber in the test liquid as specified in clause 8.3.3; the temperature shall be selected in accordance with the considerations given in clause 6 and the period of immersion should preferably be sufficient to reach the maximum absorption.

At the end of the immersion period, bring the test piece, if necessary, to the standard laboratory temperature, preferably by quickly transferring it to a fresh portion of the immersion liquid at this temperature for a period of not less than 30 min and not more than 60 min.

Remove any surplus test liquid from the surface of the test piece. The method of removing the surplus liquid will vary with the nature of the liquid. When mobile volatile liquids such as iso-octane and toluene are used, remove and quickly wipe the test piece with a filter paper or a piece of textile which does not deposit lint. Some difficulty may be experienced in completely removing viscous non-volatile oils by this method and it may be necessary to dip the test piece quickly in a suitable volatile liquid such as methanol and again quickly wipe with the filter paper or a piece of textile which does not deposit lint. Remeasure the hardness as specified in ISO 48 (micro test) at the standard laboratory temperature within an interval of 2 to 3 min after final removal from the immersion liquid.

11.2.4 Expression of results

The hardness shall be expressed in IRHD as given in ISO 48.

NOTE – It will not usually be possible to have the same thickness of the test piece before and after immersion since the immersion will change the thickness. An increase will make the hardness