



# Standard Test Method for Evaluation of Rust Preventive Characteristics of Automotive Engine Oils<sup>1</sup>

This standard is issued under the fixed designation D 6557; the number immediately following the designation indicates the year of original adoption or, in the case of revision, the year of last revision. A number in parentheses indicates the year of last reapproval. A superscript epsilon ( $\epsilon$ ) indicates an editorial change since the last revision or reapproval.

## 1. Scope

1.1 This test method covers a Ball Rust Test (BRT) procedure for evaluating the anti-rust ability of fluid lubricants. The procedure is particularly suitable for the evaluation of automotive engine oils under low-temperature, acidic service conditions.

1.2 Information Letters are published occasionally by the ASTM Test Monitoring Center (TMC)<sup>2</sup> to update this test method. Copies of these letters can be obtained by writing the center.

~~1.3 The values stated in either SI units or in other units shall be regarded separately as standard. The values stated in each system may not be exact equivalents; therefore, use each system independently of the other, without combining values in any way.~~

1.3 The values stated in SI units are provided for all parameters except where there is no direct equivalent, such as the units for screw threads, national pipe threads/diameters, and tubing size.

1.4 *This standard does not purport to address all of the safety concerns, if any, associated with its use. It is the responsibility of the user of this standard to establish appropriate safety and health practices and determine the applicability of regulatory limitations prior to use.* See 7.1.1-7.1.3 and 8.2.1.1.

## 2. Referenced Documents

### 2.1 ASTM Standards:<sup>3</sup>

D 5844 Test Method for Evaluation of Automotive Engine Oils for Inhibition of Rusting (Sequence IID)

E344 Terminology Relating to Thermometry and Hydrometry

D 6894 Test Method for Evaluation of Aeration Resistance of Engine Oils in Direct-Injected Turbocharged Automotive Diesel Engine

## 3. Terminology

### 3.1 Definitions:

3.1.1 *calibrate, v*—to determine the indication or output of a measuring device or a given engine with respect to a standard. **D 6894**

3.1.2 *corrosion, n*—the chemical or electrochemical reaction between a material, usually a metal surface, and its environment that can produce a deterioration of the material and its properties. **D 5844**

3.1.3 *non-reference oil, n*—any oil other than a reference oil, such as a research formulation, commercial oil, or candidate oil. **D 5844**

3.1.4 *reference oil, n*—an oil of known performance characteristics, used as a basis for comparison. **D 5844**

3.1.4.1 *Discussion*—Reference oils are used to calibrate testing facilities, to compare the performance of other oils, or to evaluate other materials (such as seals) that interact with oils.

3.1.5 *rust, n*—of ferrous alloys, a corrosion product consisting primarily of hydrated iron oxides. **D 5844**

3.1.6 *test oil, n*—any oil subjected to evaluation in an established procedure.

### 3.2 Definitions of Terms Specific to This Standard:

3.2.1 *average gray value (AGV), n*—measurement of brightness units on test specimens, indicating the degree of rust protection.

<sup>1</sup> This test method is under the jurisdiction of ASTM Committee D02 on Petroleum Products and Lubricants and is the direct responsibility of Subcommittee D02.B0.01 on Automotive Lubricants—Passenger Car Engine Oils.

Current edition approved May 1, 2004; Oct. 15, 2008. Published June 2004; November 2008. Originally approved in 2000. Last previous edition approved in 2003; 2004 as D 6557-034.

<sup>2</sup> Until the next revision of this test method, the ASTM Test Monitoring Center will update changes in the test method by means of information letters. Information letters may be obtained from the ASTM Test Monitoring Center, 6555 Penn Avenue, Pittsburgh, PA 15206-4489. This test method is supplemented by Information Letters and Memoranda issued by the ASTM TMC. This edition incorporates revisions in all Information Letters through No. 03-02-07-01.

<sup>3</sup> For referenced ASTM standards, visit the ASTM website, www.astm.org, or contact ASTM Customer Service at service@astm.org. For Annual Book of ASTM Standards volume information, refer to the standard's Document Summary page on the ASTM website.

3.2.2 *specimen, n*—a carbon steel ball, 7/32 in. (AISI 1040).

#### 4. Summary of Test Method

4.1 Multiple test tubes, each containing test oil and a specimen, are placed in a test tube rack, which is attached to a mechanical shaker. The shaker speed and temperature are controlled.

4.2 Air and an acidic solution are continuously fed into each test tube over an 18 h period to create a corrosive environment.

4.3 The specimens are then removed, rinsed, and analyzed by an optical imaging system designed to quantify the antirust capability of each test oil.

#### 5. Significance and Use

5.1 This bench test method was designed as a replacement for Test Method D 5844. Test Method D 5844 was designed to measure the ability of an engine oil to protect valve train components against rusting or corrosion under low temperature, short-trip service, and was correlated with vehicles in that type of service prior to 1978.<sup>4</sup>

5.1.1 Correlation between these two test methods has been demonstrated for most, but not all, of the test oils evaluated.

#### 6. Apparatus

6.1 *Specimen Preparation System*—Obtain the specimens from the Central Parts Distributor (CPD).<sup>5,6</sup>

6.1.1 Specimen preparation equipment includes various common laboratory apparatus and an ultrasonic cleaning bath.

6.2 *Air Supply System*—A compressed air supply is required, with two air filters, two pressure regulators, a gas purifier, a gassing manifold (25 port outlet), TFE-fluorocarbon tubing (25 600-ft (197-m) lengths) or equivalent multiport flow control system, and a gas mass-calibrated flowmeter (see Annex A1 and Figs. 1 and 2).

6.3 *Acid Solution Delivery System*—An acid solution delivery system that includes a multiple syringe pump with a ten position rack is required. The flow rate range minimum is 0.0001 µL/h (using a 0.5-µL syringe) to a maximum 220.82 mL/min (using a 140-mL syringe) (see Figs. 3 and 4).

6.4 *Test Tube Assembly*—The test tube assembly consists of 24 disposable plastic syringes and other common laboratory apparatus.

6.5 *Temperature and Shaking Speed Control System*—A mechanical shaker, Bench-Top Environ Shaker Model 4628,<sup>6,7</sup> provides an orbital shaking motion in a controlled speed and temperature environment.

<sup>4</sup> Withdrawn.

<sup>4</sup> Special Technical Publication, "Multicylinder Test Sequences for Evaluating Automotive Engine Oils," Part, Sequence IIID *ASTM STP 315H*, Available from ASTM Headquarters.

<sup>5</sup> Special Technical Publication, "Multicylinder Test Sequences for Evaluating Automotive Engine Oils," Part, Sequence IIID *ASTM STP 315H*, Available from ASTM Headquarters.

<sup>5</sup> The sole source of supply of the apparatus known to the committee at this time is Central Parts Distributor, Test Engineering Inc., 12718 Cimmaron Path, San Antonio, TX 78249.

<sup>6</sup> The sole source of supply of the apparatus known to the committee at this time is Central Parts Distributor, Test Engineering Inc., 12718 Cimmaron Path, San Antonio, TX 78249.

<sup>6</sup> If you are aware of alternative suppliers, please provide this information to ASTM Headquarters. Your comments will receive careful consideration at a meeting of the responsible technical committee, which you may attend.

<sup>7</sup> If you are aware of alternative suppliers, please provide this information to ASTM Headquarters. Your comments will receive careful consideration at a meeting of the responsible technical committee, which you may attend.

<sup>7</sup> The sole source of supply of the apparatus known to the committee at this time is Labine, Inc., 15<sup>th</sup> and Bloomingdale, Melrose Park, IL 60160.

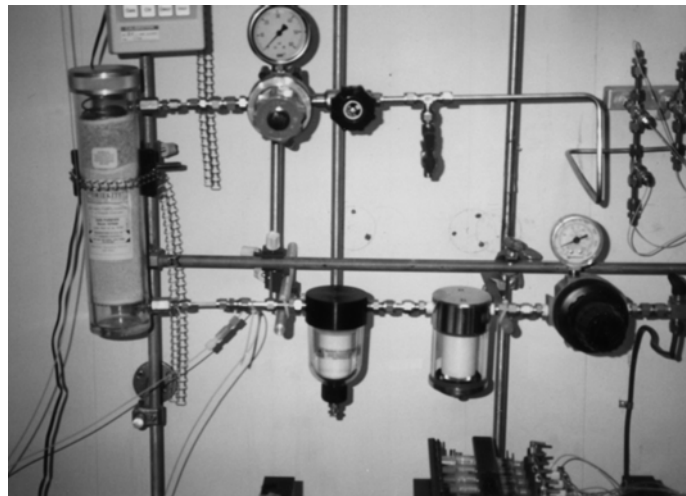

FIG. 1 Photograph of Air Delivery System

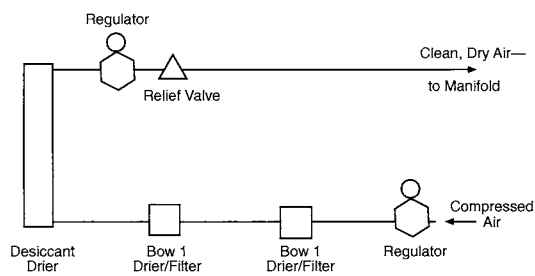

FIG. 2 Schematic of Air Delivery System



FIG. 3 Photograph of Acid Delivery System

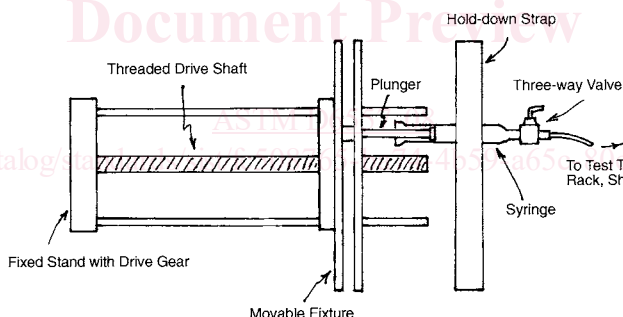

FIG. 4 Schematic of Acid Delivery System

6.5.1 A special test tube assembly rack<sup>6,8</sup> (see Figs. 5 and 6) has 24 tube positions and is attached to the shaker platform (48 by 18 in. (457 by 457 mm)).

6.6 *Gassing Manifold*—Air Delivery Manifold, required.

6.7 *Venting System*—Common laboratory apparatus is employed for the required venting system (see Fig. 7).

6.8 *Image Analysis System*—A specific imaging analysis system<sup>6,9</sup> is required. This system is composed of:

6.8.1 *Optics and Illumination:*

6.8.1.1 Nikon Epiphot 200 inverted metallurgical microscope,

6.8.1.2 BZ binocular head,

6.8.1.3 RV 3 plate mechanical stage,

6.8.1.4 CFWN 10× wide field eyepiece, high point eyepiece,

6.8.1.5 Manual BD 5 place nosepiece,

<sup>6</sup> The sole source of supply of the apparatus known to the committee at this time is Labine, Inc., 15<sup>th</sup> and Bloomingdale, Melrose Park, IL 60160.

<sup>8</sup> The sole source of supply of the apparatus known to the committee at this time is West End Machine and Weld, Inc., P.O. Box 9444, Richmond, VA 23228.

<sup>9</sup> The sole source of supply of the apparatus known to the committee at this time is West End Machine and Weld, Inc., P.O. Box 9444, Richmond, VA 23228.

<sup>9</sup> The sole source of supply of the apparatus known to the committee at this time is Meyer Instruments, Inc., 1304 Langham Creek, Suite 235, Houston, TX 77084.

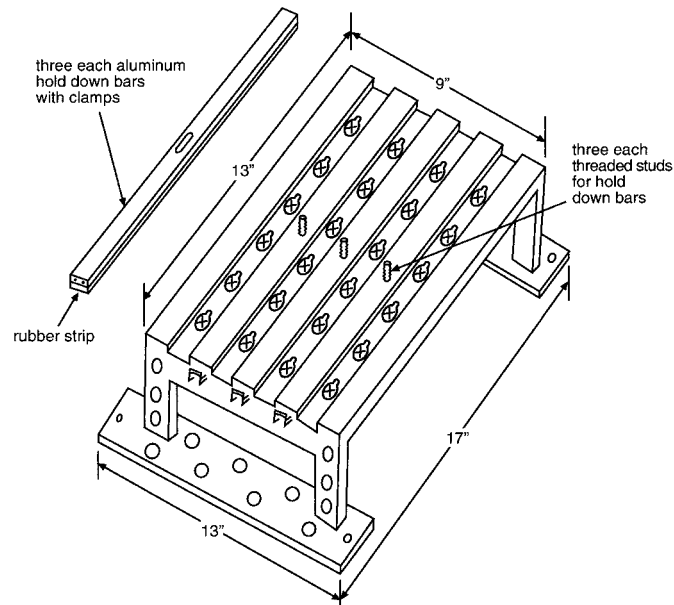

FIG. 5 Test Tube Assembly Rack

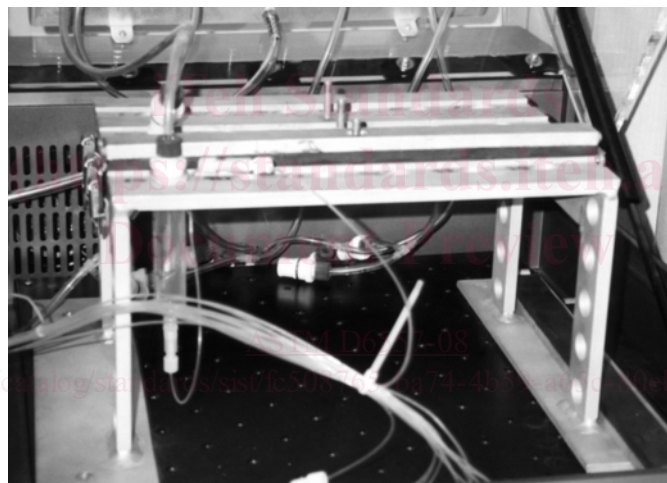

FIG. 6 Photograph of Test Tube Assembly Rack

- 6.8.1.6 Epiphot 300 EB block,
- 6.8.1.7 DF module,
- 6.8.1.8 CF BD plan 5×/0.13 plan achromat objective,
- 6.8.1.9 CF BD plan 10×/0.13 plan achromat objective,
- 6.8.1.10 EPI polarizer,
- 6.8.1.11 Analyzer,
- 6.8.1.12 Lamphouse for 12 V/100 W quartz halogen light source,
- 6.8.1.13 Lamphouse adapter,
- 6.8.1.14 12 V/100 W halogen bulbs,
- 6.8.1.15 300/200 100 W power supply,
- 6.8.1.16 Remote control cable,
- 6.8.1.17 C-mount coupler for video camera,
- 6.8.1.18 NCB 11 filter,
- 6.8.1.19 Power cords, and
- 6.8.1.20 Ultracentrifuge tube spacer with a 5-mm hole drilled in the center (used as a sample holder and sample randomizer for sample orientation).

6.8.2 *Image Capture Hardware and Software:*

- 6.8.2.1 Research grade, high resolution, NTSC RGB/RS-170 camera system,
- 6.8.2.2 Research grade, high resolution, NTSC RGB/RS-170 frame grabber,

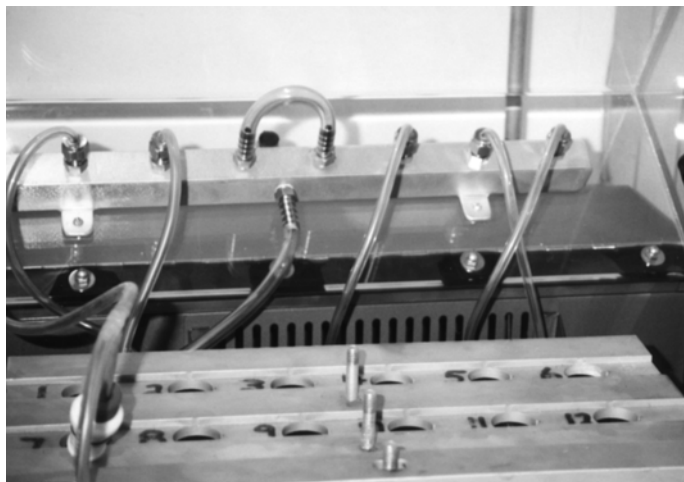

FIG. 7 Gassing Manifold for Venting

6.8.2.3 The host computer system (shall meet or exceed the following specifications):

(1) *Hardware*—Pentium 133 MHz CPU, 16 MB RAM, 540 MB hard drive, 1.44 MB 3.5-in. floppy, 1.44 MB 5.25-in. floppy (optional), CD-ROM (highly recommended option), 101 or Windows 95 keyboard, SVGA local bus video card with 2 MB RAM (4 MB recommended), 2 button serial mouse with pad, 2 parallel ports, and 2 serial ports.

(2) *Software*—Windows 3.x/DOS 6.22 or Windows 95 Operating System, Microsoft Excel 7.0 (Microsoft Office 97 recommended).

(3) *Monitor*—Medical grade high-resolution 19-in. NTSC RGB color video monitor, all necessary cables, connectors, and adapters (including a surge and spike suppressing power strip).

6.8.3 *BRT Image Analysis Software:*

6.8.3.1 BRT macro program, and

6.8.3.2 Optimate image analysis engine.

## 7. Reagents and Materials

7.1 *Reagents:*

7.1.1 *Acid Solution* (**Warning**—Corrosive. Combustible. Health hazard)—Obtain the acid solution from the CPD.

NOTE 1—For information only. Appendix X1 contains details of the acid solution.

7.1.2 *Acetone*, 99.5 %. (**Warning**—Flammable. Health hazard.)

7.1.3 *n-Heptane*, 38 to 42 % (purity), commercial grade, with C<sub>7</sub> isomers. (**Warning**—Flammable. Health hazard.)

7.2 *Materials:*

7.2.1 *TFE-fluorocarbon FEP Tubing*, 1/32-in. I.D. by 1/16-in. outside diameter (O.D.); 17 rolls of 1000 ft (328 m)/roll. (Not required if the optional NRS flow controller<sup>6,10</sup> is used.)

7.2.2 *Vinyl Tubing*, 1/8 in.-inside diameter (I.D.) by 1/4 in.-O.D.; about 15 ft.-in.-O.D.; about 15 ft (5 m).

7.2.3 *Miscellaneous Common Laboratory Equipment*, including glassware, tubing fittings, trays, vials, and plastic syringes.

## 8. Preparation of Apparatus

8.1 *Specimens:*

8.1.1 Remove the appropriate number of specimens from vacuum-sealed packages into a 4-oz (100-cc) bottle (clear, medium-round with cap). Add sufficient heptane (see 7.1.3); ~~approximately 2 oz, to cover specimens.~~ approximately 2 oz (60 cc), to cover specimens.

8.1.2 Cap the bottle loosely and place it in an ultrasonic cleaning bath. Sonicate for 30 min, and then decant the heptane.

8.1.3 Rinse two more times with heptane and follow with an acetone (see 7.1.2) rinse to ensure the specimens are free of contamination. Dry the specimens with nitrogen for ~~3 min.~~ 30 to 60 s.

NOTE 2—The specimens can be prepared up to one week in advance and stored in heptane until needed for testing.

8.2 *Test Tube Assembly, Tube Rack, and Shaker for Each Test Tube:*

8.2.1 Cut 24 separate pieces of TFE-fluorocarbon FEP tubing, each piece to be 9.5-in. (24-cm) long.

<sup>40</sup> The sole source of supply of the apparatus known to the committee at this time is Meyer Instruments, Inc., 1304 Langham Creek, Suite 235, Houston, TX 77084.

<sup>10</sup> Brooks Model 8744 NRS Flow Controller has been determined to be acceptable for this application. The sole source of supply of the apparatus known to the committee at this time is McPac Process Automation and Control, 8040 Bavaria Rd., Twinsburg, OH 44087.

8.2.1.1 Use compressed air (for technical use only), 50 psig (347 kPa) minimum, to remove most of the water/oil emulsion that may be trapped inside the short lengths of capillary tubing. Clean the tubing with heptane (see 7.1.3), followed by acetone (see 7.1.2), and dry with compressed air.

8.2.2 Check the flangeless fitting for 1/16-in. O.D. TFE-fluorocarbon tubing for deterioration, and replace as necessary.

8.2.3 Remove and discard the plunger from a new 20-mL disposable plastic syringe (Luer-Lok), and securely fasten the syringe barrel to the short capillary tubing, using couplings, 1/4-28 thread, and female Luer CTFE fittings, 1/4-28 thread, and with a 1.5-mm bore.

8.2.3.1 Label the syringes (test tubes) from 1 to 24.

8.2.4 Place the assembled test tube in the tube rack with the capillary tubing facing upward in the adjacent small hole.

8.2.4.1 The test tube assembly rack is a specially designed aluminum fabrication. It holds 24 test tubes with easy snap-on lock, wing nuts, and hold-down bars (see Fig. 5).

8.2.5 Place one precleaned specimen into each test tube, using extra-long forceps (~~7~~ that are 7 in. (175 mm) with serrated tips) to avoid contamination.

8.2.6 Insert 10 mL of test oil into each test tube, using a 10-mL disposable syringe.

8.2.7 Secure the test tubes to the tube holder with three hold-down bars and three wing nuts.

8.2.8 Fasten the test tube assembly rack to the shaker platform with four custom-made wing bolts.

### 8.3 Acid Delivery System:

8.3.1 Withdraw 6 mL of acid solution by hand from a wide-mouth beaker into an individual 5-mL disposable plastic syringe (Luer-Lok).

8.3.1.1 Attach the syringe to an acid inlet port of one of the 24 three-way switching valves, with 1/4-28 thread. (The other two ports are used for air inlet and mixed air/acid outlet.)

8.3.2 Turn the three-way valve to *two-way open* and eject, by hand, about 0.5 mL of acid solution into a waste beaker, while ensuring that no air bubbles remain in the syringe.

8.3.2.1 Place the syringe that now contains about 5.5 mL of acid solution on the holder of the multiple syringes pump.

8.3.3 Repeat the above procedure for the other 23 acid delivery syringes.

8.3.4 There are three multiple syringe pumps, and eight of the 5-mL syringes are attached to each of the pumps.

8.3.4.1 The pumps each have a ten-position rack and are required to satisfy a flow rate range of 0.0001  $\mu$ L/h, minimum, to 220.82 mL/min, maximum. Required accuracy is  $\pm 1\%$ , and reproducibility is  $\pm 0.1\%$ .

8.3.5 Ensure that the syringe barrel flange and the plunger flange are firmly held by the six retaining clamps (~~six clamps, which are 2-in. (51-mm) C-clamps that secure the ends of the hold-down bars of the multiple syringes pump~~)-pump.

8.3.5.1 Good alignment of all 24 acid delivery syringes against the retaining brackets is crucial to ensure repeatability. (See Fig. 3 for a photograph of the acid delivery system, and Fig. 4 for a schematic.)

8.3.6 Cut 24 pieces of TFE-fluorocarbon tubing; each piece to be  $51 \pm 1$  in. ( $1295 \pm 25$  mm) in length.

8.3.6.1 Attach each of these tubes to the mixed air/acid outlet ports of the three-way switching valves.

### 8.4 Air Delivery System:

8.4.1 Clean, dry air, compressed to at least 50 psig (347 kPa), is required.

8.4.2 A single stage, high-purity stainless steel pressure regulator is the first in the line; this is equipped with a 0 to 160-psi maximum pressure gauge.

8.4.3 Two compressed air filters capable of removing particles and mists are required, and are next in the line.

8.4.3.1 The first filter in the line is an A912-DX type, followed by an A912-BX type. These have polycarbonate bowls and should be equipped with aluminum shields. They have 1/4-in. NPT (F) ports and will withstand 150-psig pressure maximum.

NOTE 3—Alternatively, zero grade air cylinders can be used and will not require the extensive filtering outlined above.

8.4.4 A Drierite gas purifier, with a maximum working pressure of 100 psig (690 kPa), is next in the line.

8.4.4.1 The first portion of the purifier (about 75 %) contains a molecular sieve, activated, Type 4A, 8 to 12 mesh.

8.4.4.2 The remaining portion of the purifier (about 25 %) contains Drierite absorbent, color indicating type, 8 mesh.

8.4.5 Next in the line is the downstream regulator, single stage high-purity stainless steel, which is equipped with a 0 to 60-psi (0 to 415-kPa) pressure gauge.

8.4.6 The next installation is a relief valve, in-line adjustable CA series, 50 to 150-psi (345 to 1035-kPa) cracking pressure range, set at 80 psi (550 kPa) (optional to control over pressure).

8.4.7 Lastly, a ~~gassing~~ install an air delivery manifold with 25 port outlets and 1/4-in. tube fittings is installed. ~~fittings~~. (See Figs. 51 and 62 for a ~~schematic photograph~~ and ~~photograph schematic~~ of the air system.)

8.4.8 Cut 25 pieces of the TFE-fluorocarbon tubing, each piece to be approximately 600 ft (197 m) in length.

8.4.8.1 These long tubes provide the necessary backpressure to allow good control of the very low airflow rate. The individual lengths may need to be adjusted slightly to ensure the same flow rates at a given delivery pressure. An equivalent multiport flow control system can be used.<sup>6,10</sup>

8.4.8.2 Connect these tubes to the ~~gassing~~ air delivery manifold.

(1) ~~One~~ Connect one of these tubes is then connected to a gas mass calibrated flowmeter, capable of measuring up to 200 mL/min, and with 0.1-mL/min resolution (see Annex A1).