



Designation: E1019 – 08

Standard Test Methods for Determination of Carbon, Sulfur, Nitrogen, and Oxygen in Steel, Iron, Nickel, and Cobalt Alloys by Various Combustion and Fusion Techniques¹

This standard is issued under the fixed designation E1019; the number immediately following the designation indicates the year of original adoption or, in the case of revision, the year of last revision. A number in parentheses indicates the year of last reapproval. A superscript epsilon (ϵ) indicates an editorial change since the last revision or reapproval.

This standard has been approved for use by agencies of the Department of Defense.

1. Scope

1.1 These test methods² cover the determination of carbon, sulfur, nitrogen, and oxygen, in steel and in iron, nickel, and cobalt alloys having chemical compositions within the following limits:

Element	Concentration Range, %
Aluminum	0.001 to 18.00
Antimony	0.002 to 0.03
Arsenic	0.0005 to 0.10
Beryllium	0.001 to 0.05
Bismuth	0.001 to 0.50
Boron	0.0005 to 1.00
Cadmium	0.001 to 0.005
Calcium	0.001 to 0.05
Carbon	0.001 to 4.50
Cerium	0.005 to 0.05
Chromium	0.005 to 35.00
Cobalt	0.01 to 75.0
Columbium	0.002 to 6.00
Copper	0.005 to 10.00
Hydrogen	0.0001 to 0.0030
Iron	0.01 to 100.0
Lead	0.001 to 0.50
Magnesium	0.001 to 0.05
Manganese	0.01 to 20.0
Molybdenum	0.002 to 30.00
Nickel	0.005 to 84.00
Nitrogen	0.0005 to 0.50
Oxygen	0.0005 to 0.03
Phosphorus	0.001 to 0.90
Selenium	0.001 to 0.50
Silicon	0.001 to 6.00
Sulfur (Metal Reference Materials)	0.002 to 0.35
Sulfur (Potassium Sulfate)	0.001 to 0.600
Tantalum	0.001 to 10.00
Tellurium	0.001 to 0.35
Tin	0.002 to 0.35
Titanium	0.002 to 5.00
Tungsten	0.005 to 21.00

Vanadium	0.005 to 5.50
Zinc	0.005 to 0.20
Zirconium	0.005 to 2.500

1.2 The test methods appear in the following order:

Sections	
Carbon, Total, by the Combustion-Instrumental Measurement Test Method	10-20
Nitrogen by the Inert Gas Fusion-Thermal Conductivity Test Method	32-42
Oxygen by the Inert Gas Fusion Test Method	43-54
Sulfur by the Combustion-Infrared Absorption Test Method (Calibration with Metal Reference Materials)	55-65
Sulfur by the Combustion-Infrared Absorption Test Method (Potassium Sulfate Calibration)	21-31

1.3 The values stated in SI units are to be regarded as standard. No other units of measurement are included in this standard.

1.4 *This standard does not purport to address all of the safety concerns, if any, associated with its use. It is the responsibility of the user of this standard to establish appropriate safety and health practices and determine the applicability of regulatory limitations prior to use.* Specific hazards statements are given in Section 6.

2. Referenced Documents

2.1 *ASTM Standards:*³

- [E29 Practice for Using Significant Digits in Test Data to Determine Conformance with Specifications](#)
- [E50 Practices for Apparatus, Reagents, and Safety Considerations for Chemical Analysis of Metals, Ores, and Related Materials](#)
- [E135 Terminology Relating to Analytical Chemistry for Metals, Ores, and Related Materials](#)
- [E173 Practice for Conducting Interlaboratory Studies of Methods for Chemical Analysis of Metals](#)⁴

¹ These test methods are under the jurisdiction of ASTM Committee E01 on Analytical Chemistry for Metals, Ores, and Related Materials and are the direct responsibility of Subcommittee E01.01 on Iron, Steel, and Ferroalloys.

Current edition approved Nov. 1, 2008. Published November 2008. Originally approved in 1984. Last previous edition approved in 2003 as E1019 – 03. DOI: 10.1520/E1019-08.

² Some of these test methods represent revisions of test methods covered by Test Methods E350, E351, E352, E353, and E354, which appear in the *Annual Book of ASTM Standards*, Vol 03.05.

³ For referenced ASTM standards, visit the ASTM website, www.astm.org, or contact ASTM Customer Service at service@astm.org. For *Annual Book of ASTM Standards* volume information, refer to the standard's Document Summary page on the ASTM website.

⁴ Withdrawn. The last approved version of this historical standard is referenced on www.astm.org.

E1601 Practice for Conducting an Interlaboratory Study to Evaluate the Performance of an Analytical Method

E1806 Practice for Sampling Steel and Iron for Determination of Chemical Composition

3. Terminology

3.1 For definition of terms used in this test method, refer to Terminology **E135**.

4. Significance and Use

4.1 These test methods for the chemical analysis of metals and alloys are primarily intended to test such materials for compliance with compositional specifications. It is assumed that all who use these test methods will be trained analysts, capable of performing common laboratory procedures skillfully and safely. It is expected that work will be performed in a properly equipped laboratory.

5. Apparatus and Reagents

5.1 Apparatus and reagents required for each determination are listed in separate sections preceding the procedure.

6. Hazards

6.1 For hazards to be observed in the use of certain reagents in this test method, refer to Practices **E50**.

6.2 Use care when handling hot crucibles and operating furnaces to avoid personal injury by either burn or electrical shock.

7. Sampling

7.1 For procedures for sampling the materials, refer to those parts of Practice **E1806**.

8. Rounding Calculated Values

8.1 Calculated values shall be rounded to the desired number of places as directed in Practice **E29**.

9. Interlaboratory Studies

9.1 These test methods have been evaluated in accordance with Practice **E173**. The Reproducibility R_2 of Practice **E173** corresponds to the Reproducibility Index R of Practice **E1601**. The Repeatability R_1 of Practice **E173** corresponds to the Repeatability Index r of Practice **E1601**.

TOTAL CARBON BY THE COMBUSTION INSTRUMENTAL MEASUREMENT TEST METHOD

10. Scope

10.1 This test method covers the determination of carbon in concentrations from 0.005 % to 4.5 %.

11. Summary of Test Method

11.1 The carbon is converted to carbon dioxide by combustion in a stream of oxygen.

11.1.1 *Thermal Conductivity Test Method*—The carbon dioxide is absorbed on a suitable grade of zeolite, released by heating the zeolite, and swept by helium or oxygen into a

chromatographic column. Upon elution, the amount of carbon dioxide is measured in a thermistor-type conductivity cell. Refer to **Fig. 1**.

11.1.2 *Infrared (IR) Absorption, Test Method A*—The amount of carbon dioxide is measured by infrared (IR) absorption. Carbon dioxide (CO_2) absorbs IR energy at a precise wavelength within the IR spectrum. Energy of this wavelength is absorbed as the gas passes through a cell body in which the IR energy is transmitted. All other IR energy is eliminated from reaching the detector by a precise wavelength filter. Thus, the absorption of IR energy can be attributed to only CO_2 and its concentration is measured as changes in energy at the detector. One cell is used as both a reference and a measure chamber. Total carbon, as CO_2 , is monitored and measured over a period of time. Refer to **Fig. 2**.

11.1.3 *Infrared (IR) Absorption, Test Method B*—The detector consists of an IR energy source, a separate measure chamber and reference chamber, and a diaphragm acting as one plate of a parallel plate capacitor. During specimen combustion, the flow of CO_2 with its oxygen gas carrier is routed through the measure chamber while oxygen alone passes through the reference chamber. Energy from the IR source passes through both chambers, simultaneously arriving at the diaphragm (capacitor plate). Part of the IR energy is absorbed by the CO_2 present in the measure chamber while none is absorbed passing through the reference chamber. This creates an IR energy imbalance reaching the diaphragm, thus distorting it. This distortion alters the fixed capacitance creating an electric signal change that is amplified for measurement as CO_2 . Total carbon, as CO_2 , is monitored and measured over a period of time. Refer to **Fig. 3**.

11.1.4 *Infrared (IR) Absorption, Test Method C, Closed Loop*—The combustion is performed in a closed loop, where CO and CO_2 are detected in the same infrared cell. Each gas is measured with a solid state energy detector. Filters are used to pass the appropriate IR wavelength to each detector. In the absence of CO and CO_2 , the energy received by each detector is maximum. During combustion, the IR absorption properties of CO and CO_2 gases in the chamber cause a loss of energy; therefore a loss in signal results which is proportional to concentrations of each gas in the closed loop. Total carbon, as CO_2 plus CO, is monitored and measured over a period of time. Refer to **Fig. 4**.

11.2 This test method is written for use with commercial analyzers, equipped to perform the above operations automatically and calibrated using steels of known carbon content.

12. Interferences

12.1 The elements ordinarily present do not interfere.

13. Apparatus

13.1 *Combustion and Measurement Apparatus*—See **Figs. 1-4**.

13.2 *Crucibles*—Use crucibles that meet or exceed the specifications of the instrument manufacturer and preheat in a suitable furnace for not less than 40 min at approximately 1000 °C. Remove from the furnace and cool before use. Crucibles may be stored in a desiccator prior to use. Preheating of crucibles is particularly important for low levels of carbon.

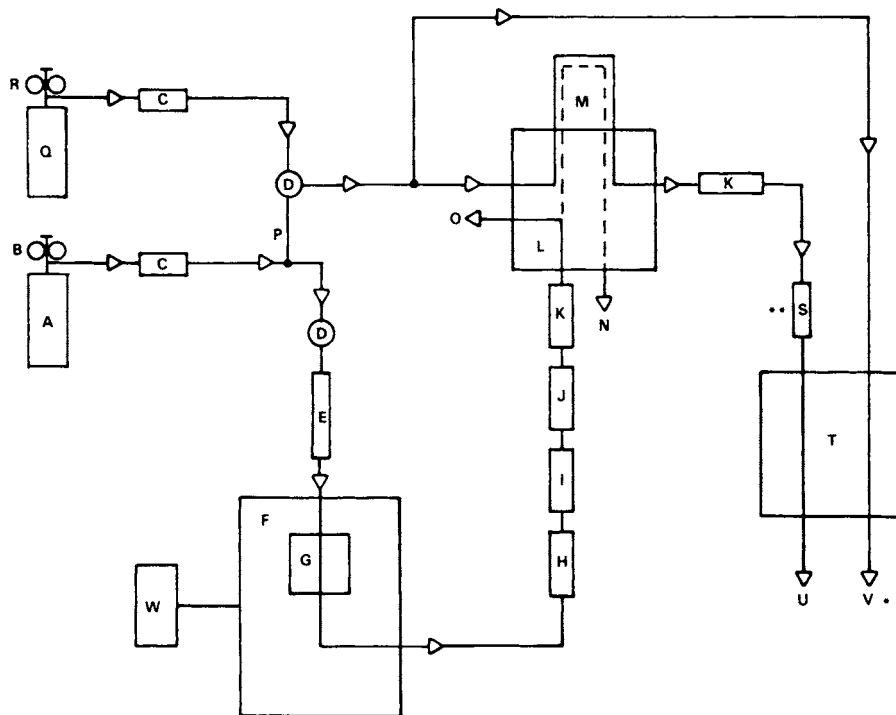

- | | |
|---|---|
| <p>A—High Purity Oxygen
 B—Oxygen Regulator (2 Stage)
 C—Sodium Hydroxide Impregnated Clay/Magnesium Perchlorate
 D—Secondary Pressure Regulator
 E—Flowmeter
 F—Induction Furnace
 G—Combustion Tube
 H—Dust Trap
 I—Manganese Dioxide
 J—Heated CO to CO₂ Converter
 K—Magnesium Perchlorate
 L—Valve Manifold</p> | <p>M—CO₂ Collection Trap
 N—Furnace Combustion Exhaust
 O—Furnace Purge Exhaust
 P—Metal Connector To Use Oxygen As Carrier Gas
 Q—High Purity Helium
 R—Helium Regulator (2 Stage)
 S—Chromatographic Column
 T—TC Cell/Readout
 U—Measure Flowmeter
 V—Reference Flowmeter
 W—Furnace Power Stat</p> |
|---|---|

* May be sealed chamber if oxygen is carrier gas.

** Not required if oxygen is carrier gas.

FIG. 1 Apparatus for Determination of Carbon by the Combustion Thermal Conductivity Test Method

It may not be required for the determination of higher levels of carbon such as those found in pig iron.

13.3 *Crucible Tongs*—Capable of handling recommended crucibles.

14. Reagents

14.1 *Purity of Reagents*—Reagent grade chemicals shall be used in all tests. Unless otherwise indicated, it is intended that all reagents shall conform to the specifications of the Committee on Analytical Reagents of the American Chemical Society, where such specifications are available.⁵ Other grades may be used, provided it is first ascertained that the reagent is of

sufficiently high purity to permit its use without lessening the accuracy of the determination.

14.2 *Acetone*—The residue after evaporation must be < 0.0005 %.

14.3 *Copper (Low Carbon)*, granular (10 to 30 mesh) (**Note 1**).

14.4 *Magnesium Perchlorate*, (known commercially as *Anhydron*).

14.5 *Oxygen, Ultra High Purity (purity: 99.95 % minimum)*—Other grades of oxygen may be used if low and consistent blank readings are obtained, or the oxygen may be purified as described in Practices E50.

14.6 *Platinum or Platinized Silica*, heated to 350 °C for the conversion of carbon monoxide to carbon dioxide.

14.7 *Sodium Hydroxide*, on clay (known commercially as *Ascarite II*).

14.8 *Tungsten (Low Carbon) Accelerator*, 12 to 20 mesh (**Note 1**).

⁵ *Reagent Chemicals, American Chemical Society Specifications*, American Chemical Society, Washington, DC, www.chemistry.org. For suggestions on the testing of reagents not listed by the American Chemical Society, see the *United States Pharmacopeia and National Formulary*, U.S. Pharmacopeial Convention, Inc. (USPC), Rockville, MD, http://www.usp.org.

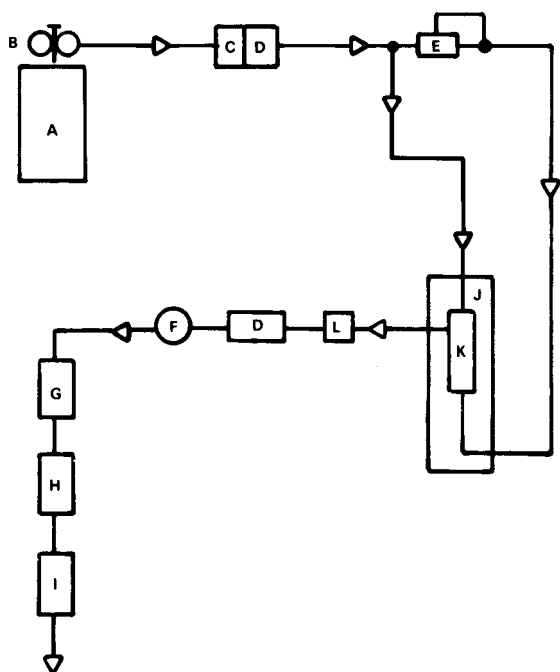

- | | |
|-------------------------------------|-----------------------------------|
| A—Oxygen Cylinder | G—CO-CO ₂ Converter |
| B—Two Stage Regulator | H—SO ₃ Trap |
| C—Sodium Hydroxide Impregnated Clay | I—CO ₂ IR Cell/Readout |
| D—Magnesium Perchlorate | J—Induction Furnace |
| E—Regulator | K—Combustion Area |
| F—Flow Controller | L—Dust Trap |

FIG. 2 Infrared Absorption Test Method A

14.9 Tungsten-Tin (Low Carbon) Accelerator, 20 to 40 mesh or 12 to 20 mesh.

NOTE 1—The accelerator should contain no more than 0.001 % carbon. If necessary, wash three times with acetone by decantation to remove organic contaminants and dry at room temperature. The mesh size is critical to the inductive coupling which heats the sample. Some manufacturers of accelerators may not certify the mesh size on a lot to lot basis. These accelerators may be considered acceptable for use without verifying the mesh size.

15. Preparation of Apparatus

15.1 Assemble the apparatus as recommended by the manufacturer.

15.2 Test the furnace and analyzer to ensure the absence of leaks and make the required electrical power connections. Prepare the analyzer for operation according to the manufacturer's instructions. Make a minimum of two determinations using the specimen and accelerator as directed in 18.1.2 and 18.1.3 before attempting to calibrate the system or determine the blank.

16. Sample Preparation

16.1 The sample should be uniform in size, but not finer than 40 mesh.

16.2 If necessary, wash in acetone or another suitable solvent and dry.

17. Calibration

17.1 Calibration Reference Materials (Note 2):

17.1.1 For Range I, 0.005 % to 0.10 % carbon, select three certified reference materials containing approximately 0.005 %, 0.05 %, and 0.10 % carbon and designate them as Calibrants A, B, and C, respectively. Some labs may use accelerator with a certified carbon value as Calibrant A.

17.1.2 For Range II, 0.10 % to 1.25 % carbon, select two certified reference materials containing approximately 0.12 % and 1.00 % carbon and designate them as Calibrants BB and CC, respectively.

17.1.3 For Range III, 1.25 % to 4.50 % carbon, select two certified reference materials containing approximately 1.25 % and 4.00 % carbon and designate them as Calibrants BBB and CCC, respectively.

NOTE 2—The uncertainty of results obtained using this test method is dependent on the uncertainty of the values assigned to the calibration reference materials. The homogeneity of the reference materials must be considered as well, if it was not included in the derivation of the published uncertainty values.

17.2 Adjustment of Response of Measurement System:

17.2.1 Transfer 1.0 g of Calibrant B, weighed to the nearest 1 mg, and approximately 1.5 g of accelerator to a preheated crucible. Some manufacturers provide scoops that dispense approximately 1.5 g of accelerator. Once it is verified that the scoop delivers this approximate weight, it is acceptable to use this device for routine dispensing of accelerator.

17.2.2 Proceed as directed in 18.1.2 and 18.1.3.

17.2.3 Repeat 17.2.1 and 17.2.2 until the absence of drift is indicated. Adjust the signal to provide a reading within ± 0.003 of the certified percent carbon value for the certified reference material.

17.3 Determination of Blank Reading—Range I:

17.3.1 Add approximately 1.5 g of accelerator into a preheated crucible. If required, 1.0 g of Calibrant A, weighed to the nearest 1 mg, may be added to the crucible.

17.3.2 Proceed as directed in 18.1.2 and 18.1.3.

17.3.3 Repeat 17.3.1 and 17.3.2 a sufficient number of times to establish that low (less than 0.002 % of carbon) and consistent (± 0.0002 % of carbon) readings are obtained. Blank values are equal to the total result of the accelerator. If Calibrant A was used, blank values are equal to the total result of the accelerator and Calibrant A minus the certified value of Calibrant A.

17.3.4 Record the average value of at least three blank determinations.

17.3.5 If the blank readings are too high or inconsistent, determine the cause, correct it, and repeat the steps as directed in 17.3.1-17.3.4.

17.3.6 Enter the average blank value in the analyzer (Note 3); refer to manufacturer's instructions. This mechanism will electronically compensate for the blank value.

NOTE 3—If the unit does not have this function, the blank value must be subtracted from the total result prior to any calculation.

17.4 Determination of Blank Reading—Range II—Proceed as directed in 17.3.

17.5 Determination of Blank Reading—Range III:

17.5.1 Transfer 0.5 g of Calibrant A, weighed to the nearest 1 mg, and approximately 1.5 g of accelerator to a preheated crucible.

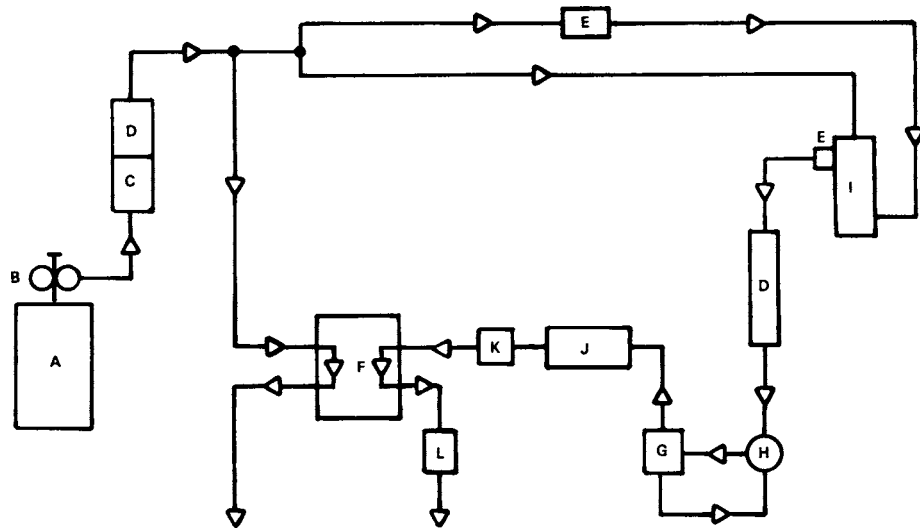

- | | |
|-------------------------------------|-----------------------------------|
| A—Oxygen Cylinder | G—Orifice |
| B—Two Stage Regulator | H—Pressure Regulator |
| C—Sodium Hydroxide Impregnated Clay | I—Combustion Chamber |
| D—Magnesium Perchlorate | J—CO to CO ₂ Converter |
| E—Dust Trap | K—SO ₃ Trap |
| F—IR Cell/Readout | L—Measure Flow Rotameter |

FIG. 3 Infrared Absorption Test Method B

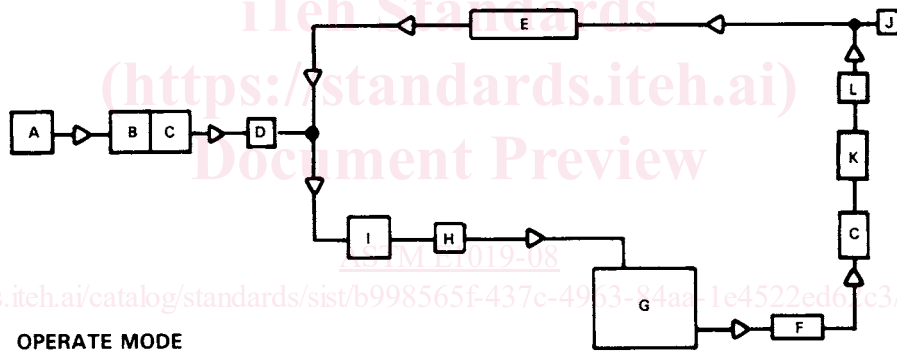

OPERATE MODE

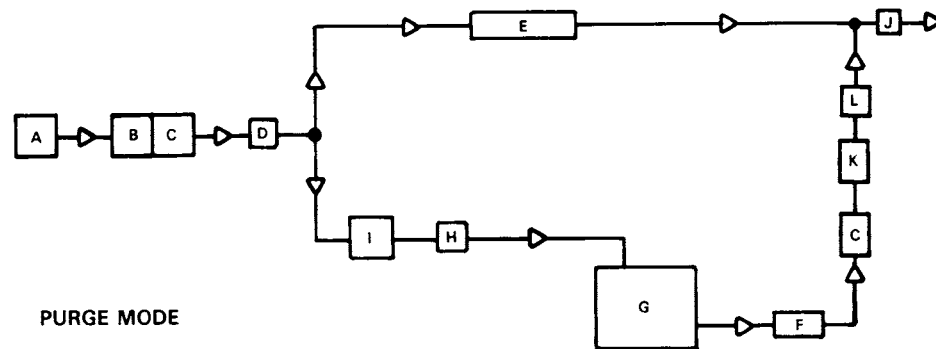

PURGE MODE

- | | |
|-------------------------------------|-----------------------------------|
| A—Oxygen Cylinder | G—Furnace |
| B—Sodium Hydroxide Impregnated Clay | H—Pump |
| C—Magnesium Perchlorate | I—Flow Meter |
| D—Press Regulator | J—Exhaust |
| E—IR Cell/Readout | K—CO to CO ₂ Converter |
| F—Dust Trap | L—SO ₃ Trap |

FIG. 4 Infrared Absorption Test Method C—Closed Loop

17.5.2 Proceed as directed in 17.3.2-17.3.6.

17.6 Calibration—Range I (0.005 % to 0.10 % carbon):

17.6.1 Weigh four 1.0 g specimens of Calibrant C, to the nearest 1 mg, then place in preheated crucibles. To each, add approximately 1.5 g of accelerator.

17.6.2 Follow the calibration procedure recommended by the manufacturer. Use Calibrant C as the primary calibrant and analyze at least three specimens to determine the calibration slope. Treat each specimen, as directed in 18.1.2 and 18.1.3, before proceeding to the next one.

17.6.3 Confirm the calibration by analyzing Calibrant C following the calibration procedure. The value should be within the uncertainty limits of the certified value for Calibrant C. If not, repeat 17.6.1 and 17.6.2.

17.6.4 Weigh at least two 1.0 g specimens of Calibrant B, weighed to the nearest 1 mg, and transfer them to preheated crucibles. To each, add approximately 1.5 g of accelerator.

17.6.5 Treat each specimen as directed in 18.1.2 and 18.1.3 before proceeding to the next one.

17.6.6 Record the results of 17.6.4 and 17.6.5 and compare them to the certified carbon value of Calibrant B. The results should be within the uncertainty limits of Calibrant B. If not, refer to the manufacturer’s instructions for checking the linearity of the system.

NOTE 4—The use of 1.5 g of accelerator may not be sufficient for all determinators. The required amount is determined by the analyzer used, induction coil spacing, position of the crucible in the induction coil, age and strength of the oscillator tube, and type of crucible being used. Use the amount required to produce proper sample combustion using the same amount throughout the entire test method.

17.7 Calibration—Range II (0.10 % to 1.25 % carbon):

17.7.1 Proceed as directed in 17.6.1-17.6.3, using Calibrant CC.

17.7.2 Proceed as directed in 17.6.4-17.6.6, using Calibrant BB.

17.8 Calibration—Range III (1.25 % to 4.50 % carbon):

17.8.1 Weigh four 0.5 g specimens of Calibrant CCC, to the nearest 1 mg, and place in preheated crucibles. To each, add approximately 1.5 g of accelerator.

17.8.2 Follow the calibration procedure recommended by the manufacturer. Use Calibrant CCC as the primary calibrant and analyze at least three specimens to determine the calibration slope. Treat each specimen, as directed in 18.1.2 and 18.1.3, before proceeding to the next one.

17.8.3 Confirm the calibration by analyzing Calibrant CCC following the calibration procedure. The value should be within the uncertainty limits of Calibrant CCC. If not, repeat 17.8.1 and 17.8.2.

17.8.4 Weigh at least two 0.5 g specimens of Calibrant BBB, weighed to the nearest 1 mg, and transfer to preheated crucibles. To each, add approximately 1.5 g of accelerator.

17.8.5 Treat each specimen as described in 18.1.2 and 18.1.3 before proceeding to the next one.

17.8.6 Record the results of 17.8.4 and 17.8.5 and compare to the certified carbon value of Calibrant BBB. The results should be within the uncertainty limits of Calibrant BBB. If not, refer to manufacturer’s instructions for checking the linearity of the analyzer (Note 5).

NOTE 5—Verify the calibration when: (1) a different lot of crucibles is used, (2) a different lot of accelerator is used, (3) the system has not been in use for 4 h, and (4) the oxygen supply has been changed. Verification should consist of analyzing at least one run of each calibrant. Recalibrate as necessary.

18. Procedure

18.1 Procedure—Range I:

18.1.1 Stabilize the furnace and analyzer as directed in Section 15. Transfer approximately 1.0 g of specimen and approximately 1.5 g of accelerator to a preheated crucible. (See 13.2.)

18.1.2 Place the crucible on the furnace pedestal and raise the pedestal into position. Use crucible tongs to handle the preheated crucibles.

18.1.3 Refer to the manufacturer’s recommended procedure regarding entry of specimen weight and blank value. Start the analysis cycle.

18.2 Procedure—Range II—Proceed as directed in 18.1.

18.3 Procedure—Range III—Proceed as directed in 18.1, using a 0.5 g specimen.

19. Calculation

19.1 Since most commercially available instruments calculate percent concentrations directly, including corrections for blank and sample weight, calculations by the analyst are not required.

NOTE 6—If the analyzer does not compensate for blank and sample weight values, then use the following formula:

$$\text{Carbon, \%} = [(A - B) \times C/D] \quad (1)$$

where:

- A = DVM reading for specimen,
- B = DVM reading for blank,
- C = weight compensator setting, and
- D = specimen weight, g.

TABLE 1 Statistical Information—Carbon, Range I

Test Specimen	Carbon Found, %	Repeatability (R_1 , Practice E173)	Reproducibility (R_2 , Practice E173)
1. Electrolytic iron (NIST 365, 0.0068 C)	0.007	0.002	0.003
2. Bessemer carbon steel (NIST 8j, 0.081 C)	0.080	0.003	0.006
3. Type 304L stainless steel 18Cr-8Ni (NIST 101f, 0.014 C)	0.014	0.002	0.004
4. Type 446 stainless steel 26Cr (NIST 367, 0.093 C)	0.094	0.003	0.004
5. Nickel steel 36Ni (NIST 126b, 0.090 C)	0.092	0.003	0.004
6. Waspaloy 57Ni-20Cr-14Co-4Mo (NIST 349, 0.080 C)	0.078	0.003	0.004
7. Silicon steel (NIST 131a, 0.004 C)	0.004	0.002	0.002
8. High temperature alloy A286 26Ni-15Cr (NIST 348, 0.044 C)	0.046	0.003	0.004

TABLE 2 Statistical Information—Carbon, Range II

Test Specimen	Carbon Found, %	Repeatability (R_1 , Practice E173)	Reproducibility (R_2 , Practice E173)
1. Basic open hearth steel (NIST 11h, 0.200 C)	0.201	0.006	0.010
2. Basic open hearth carbon steel (NIST 337, 1.07 C)	1.087	0.039	0.053
3. Low alloy electric furnace steel (NIST 51b, 1.21 C)	1.224	0.039	0.048
4. High temperature nickel alloy (LE 105, 0.130 C)	0.130	0.005	0.008
5. Tool steel 8Co-9Mo-2W-4Cr-2V (NIST 153a, 0.902 C)	0.905	0.023	0.027
6. Type 416 stainless steel (NIST 133b, 0.128 C)	0.126	0.005	0.013
7. Low alloy steel 1Cr (NIST 163, 0.933 C)	0.934	0.016	0.020

TABLE 3 Statistical Information—Carbon, Range III

Test Specimen	Carbon Found, %	Repeatability (R_1 , Practice E173)	Reproducibility (R_2 , Practice E173)
1. Tool steel (CISRI 150, 1.56 C)	1.550	0.027	0.049
2. Low alloy electric furnace steel (NIST 51b, 1.21 C)	1.228	0.039	0.050
3. Cast iron (LECO 501-105, 2.20 C)	2.202	0.044	0.056
4. Ductile iron (LECO 501-083, 4.24 C)	4.244	0.083	0.091
5. White iron (LECO 501-024, 3.25 C)	3.274	0.064	0.074
6. Iron (BAM 035-1, 1.31 C)	1.314	0.034	0.048
7. Ferritic stainless steel (BAM 228-1, 2.05 C)	2.040	0.027	0.055

20. Precision and Bias ⁶

20.1 Precision—Nine laboratories cooperated in testing this test method and obtained the data summarized in Tables 1-3. Testing was performed in compliance with Practice E173.

20.2 Bias—Information on the accuracy of this test method is incomplete at this time. The user is cautioned to verify by the use of certified reference materials, if available, that the accuracy of this test method is adequate for the contemplated use.

SULFUR BY THE COMBUSTION-IR
ABSORPTION TEST METHOD (POTASSIUM
SULFATE CALIBRATION)

21. Scope

21.1 This test method covers the determination of sulfur in the range of 0.001 % to 0.01 %. As written, this test method is not applicable to cast iron samples.

22. Summary of Test Method

22.1 The sample is combusted in a stream of oxygen that converts the sulfur in the sample to sulfur dioxide. The sulfur is then determined by infrared absorption.

22.1.1 Infrared Absorption Test Method A—Sulfur dioxide (SO₂) absorbs IR energy at a precise wavelength within the IR spectrum. Energy of this wavelength is absorbed as the gas passes through a cell body in which the IR energy is transmitted. All other IR energy is eliminated from reaching the detector by a precise wavelength filter. Therefore, the absorption of IR energy can be attributed to only SO₂ and its concentration is measured as changes in energy at the detector. One cell is used as both a reference and a measure chamber. Total sulfur, as SO₂, is monitored and measured over a period of time. Refer to Fig. 5.

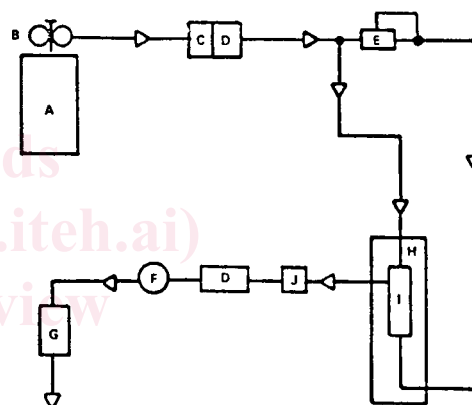

- A—Oxygen Cylinder
- B—Two Stage Regulator
- C—Sodium Hydroxide Impregnated Clay
- D—Magnesium Perchlorate
- E—Regulator
- F—Flow Controller
- G—IR Cell/Readout
- H—Induction Furnace
- I—Combustion Area
- J—Dust Trap

FIG. 5 Infrared Absorption Test Method A

22.1.2 Infrared Absorption Test Method B—The combustion is performed in a closed loop where SO₂ is detected in an infrared cell. The SO₂ is measured with a solid state energy detector, and filters are used to pass the appropriate IR wavelength to the detector. During combustion, the IR absorption properties of the SO₂ gas in the chamber causes a loss of energy, therefore a loss in signal results which is proportional to the concentration of the gas in the closed loop. Total sulfur, as SO₂, is monitored and measured over a period of time. Refer to Fig. 6.

22.1.3 Infrared Absorption Test Method C—The detector consists of an IR energy source, a separate measure chamber and reference chamber, and a diaphragm acting as one plate of a parallel plate capacitor. During specimen combustion, the flow of SO₂ with its oxygen gas carrier is routed through the measure chamber while oxygen alone passes through the reference chamber. Energy from the IR source passes through

⁶ Supporting data have been filed at ASTM International Headquarters and may be obtained by requesting Research Report RR:E01-1093.

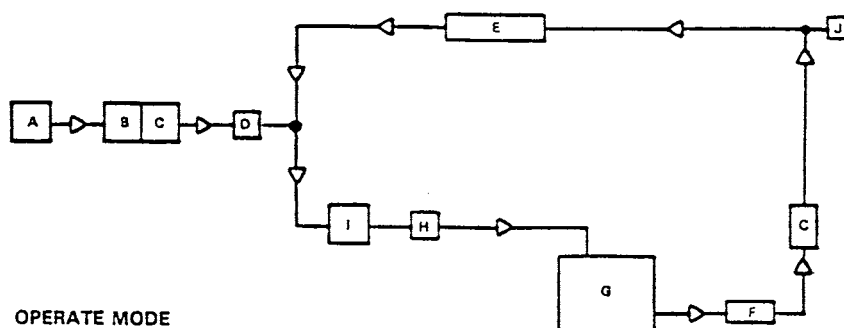

OPERATE MODE

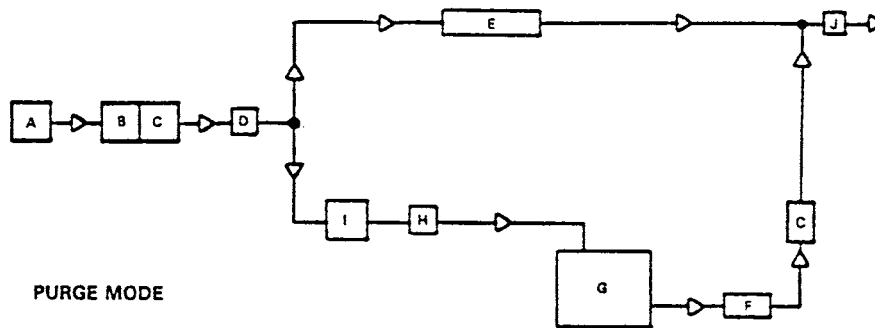

PURGE MODE

- | | |
|-------------------------------------|--------------|
| A—Oxygen Cylinder | F—Dust Trap |
| B—Sodium Hydroxide Impregnated Clay | G—Furnace |
| C—Magnesium Perchlorate | H—Pump |
| D—Press Regulator | I—Flow Meter |
| E—IR Cell/Readout | J—Exhaust |

FIG. 6 Infrared Absorption Test Method B

both chambers, simultaneously arriving at the diaphragm (capacitor plate). Part of the IR energy is absorbed by the SO₂ present in the measure chamber while none is absorbed passing through the reference chamber. This creates an IR energy imbalance reaching the diaphragm, thus distorting it. This distortion alters the fixed capacitance creating an electric signal change that is amplified for measurement as SO₂. Total SO₂ is monitored and measured over a period of time. Refer to Fig. 7.

23. Interferences

23.1 The elements ordinarily present do not interfere.

24. Apparatus

24.1 *Combustion and Measurement Apparatus*—See Figs. 5-7.

24.2 *Crucibles*—Use crucibles recommended by the manufacturer of the instrument, or equivalent, and preheat in a suitable furnace for not less than 1 h at approximately 1000 °C. Remove from furnace and cool before use. Preheated crucibles may be stored in a desiccator prior to use.

24.3 *Micropipet*, (50 µL).

24.4 *Crucible Tongs*—Capable of handling recommended crucibles.

24.5 *Tin Capsules*—Approximate dimensions: diameter 6 mm, length 20 mm. Wash twice with acetone or another suitable solvent and dry at approximately 90 °C for not less than 4 h prior to use.

25. Reagents

25.1 *Purity of Reagents*—Reagent grade chemicals shall be used in all tests. Unless otherwise indicated, it is intended that all reagents shall conform to the specifications of the Committee on Analytical Reagents of the American Chemical Society, where such specifications are available.⁵ Other grades may be used, provided it is first ascertained that the reagent is of sufficiently high purity to permit its use without lessening the accuracy of the determination.

25.2 *Acetone*—The residue after evaporation must be < 0.0005 %.

25.3 *Iron (purity, 99.8 % minimum)*—Must be free of sulfur or contain a low known sulfur content.

25.4 *Magnesium Perchlorate*, (known commercially as *Anhydron*).

25.5 *Oxygen, Ultra High Purity (purity: 99.95 % min)*—Other grades of oxygen may be used if low and consistent blank readings are obtained, or the oxygen may be purified as described in Practices E50.

25.6 *Potassium Sulfate (K₂SO₄)*—Dry 20 g of K₂SO₄ at 105 °C to 110 °C for not less than 1 h to a constant weight. Cool in a desiccator.

25.7 *Sodium Hydroxide*, on clay (known commercially as *Ascarite II*).

25.8 *Tungsten Accelerator (Low Sulfur)*, 12 to 20-mesh.

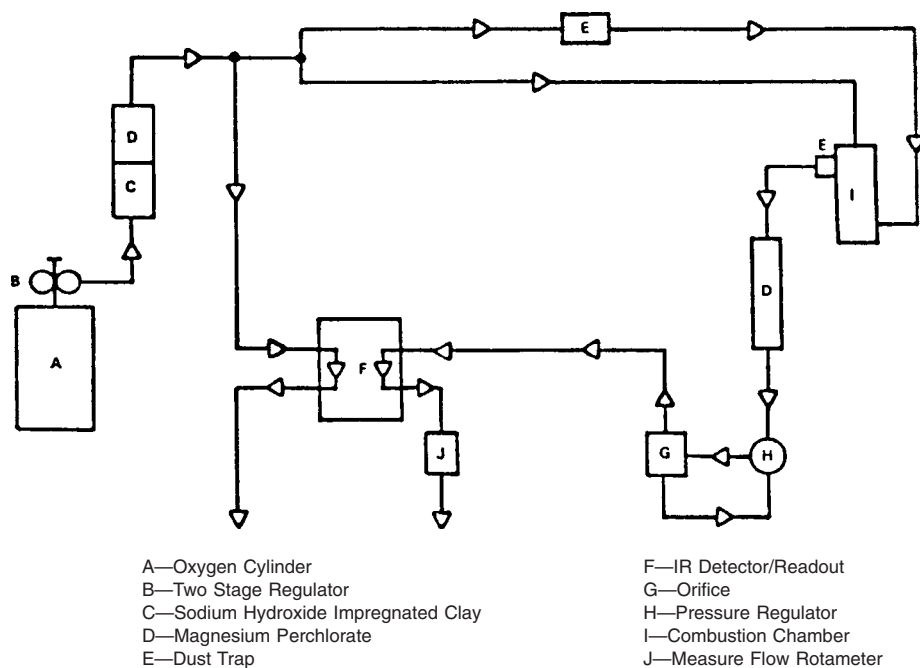

FIG. 7 Infrared Absorption Test Method C

25.9 Tungsten-Tin Accelerator, 20 to 40 mesh or 12 to 20 mesh.

NOTE 7—The accelerator should contain no more than 0.001 % sulfur. If necessary, wash three times with acetone or another suitable solvent by decantation to remove organic contaminants and dry at room temperature. The mesh size is critical to the inductive coupling that heats the sample. Some manufacturers of accelerators may not certify the mesh size on a lot to lot basis. These accelerators may be considered acceptable for use without verifying the mesh size.

26. Preparation of Apparatus

26.1 Assemble the apparatus as recommended by the manufacturer.

26.2 Test the furnace and analyzer to ensure the absence of leaks, and make the required electrical power connections. Prepare the analyzer for operation according to manufacturer's instructions. Make a minimum of two determinations using the specimen and accelerator as directed in 29.2 and 29.3 before attempting to calibrate the system or determine the blank.

27. Sample Preparation

27.1 The sample should be uniform in size but not finer than 40 mesh.

27.2 If necessary, wash in acetone or another suitable solvent and dry at 70 °C to 100 °C.

28. Calibration

28.1 Calibration Reference Materials:

28.1.1 Weigh to the nearest 0.0001 g the following masses of K₂SO₄:

Sulfur Solution	K ₂ SO ₄ (g)	Sulfur Concentration (mg/mL)
A	0.1087	0.2
B	0.2718	0.5
C	0.5435	1.0
D	1.0870	2.0

Sulfur Solution	K ₂ SO ₄ (g)	Sulfur Concentration (mg/mL)
H	0.0000	0.0

28.1.2 Dissolve each portion of K₂SO₄ in 50 mL of water in five 100-mL beakers.

28.1.3 Transfer quantitatively each solution to five 100-mL volumetric flasks. Dilute to volume and mix.

28.1.4 Using a pipet, transfer 50 µL of the following sulfur solutions to individual tin capsules. Prepare the number of replicates indicated and then proceed as directed in 28.1.5.

Sulfur Solution	S (µg)	S, % in the Test Portion	Number of Replicates
H	0	0.0000	5
A	10	0.0010	2
B	25	0.0025	5
C	50	0.0050	2
D	100	0.0100	5

28.1.5 Dry the tin capsules slowly at about 90 °C to full dryness, and cool in a desiccator. Compress the top part of the tin capsule before use.

28.2 Adjustment of Response of Measurement System:

28.2.1 Transfer one dried capsule of sulfur solution B to a preheated crucible. Add approximately 1.0 g of pure iron, weighed to the nearest 5 mg, and approximately 1.5 g of tungsten accelerator to the crucible. Proceed as directed in 29.2 and 29.3.

28.2.2 Repeat 28.2.1 until the absence of drift is indicated. (Prepare more capsules of sulfur solution B if necessary.) Adjust the signal to provide a reading of 0.0025 % ± 0.0003 % sulfur.

28.3 Determination of Blank Reading:

28.3.1 Transfer one dried capsule of sulfur solution H to a preheated crucible. Add approximately 1.0 g of pure iron, weighed to the nearest 5 mg, and approximately 1.5 g of accelerator to the crucible. Some manufacturers provide scoops

that dispense approximately 1.5 g of accelerator. Once it is verified that the scoop delivers this approximate weight, it is acceptable to use this device for routine dispensing of accelerator. Proceed as directed in 29.2 and 29.3.

28.3.2 Repeat 28.3.1 a sufficient number of times to establish that low (less than 5 µg of sulfur) and consistent (± 2 µg of sulfur) readings are obtained. Blank values are equal to the total result of accelerator, iron, and capsule of solution H.

28.3.3 Record the average value of at least three blank determinations.

28.3.4 If the blank readings are too high or inconsistent, determine the cause, correct it, and repeat the steps as directed in 28.3.1-28.3.3. Prepare more capsules of sulfur solution H if necessary.

28.3.5 Enter the average blank value in the analyzer (Note 8). Refer to manufacturer's instructions. This mechanism will electronically compensate for the blank value.

NOTE 8—If the unit does not have this function, the blank value must be subtracted from the total result prior to any calculation.

28.4 Calibration:

28.4.1 Transfer four dried capsules of sulfur solution D to preheated crucibles. Add approximately 1.0 g of pure iron, weighed to the nearest 5 mg, and approximately 1.5 g of accelerator to each crucible.

28.4.2 Follow calibration procedure recommended by the manufacturer using dried capsules of sulfur solution D as the primary calibrant, analyzing at least three specimens to determine the calibration slope. Treat each capsule as directed in 29.2 and 29.3 before proceeding to the next one.

28.4.3 Confirm the calibration by analyzing a capsule of sulfur solution D after the calibration procedure. The value should be 0.0100 % \pm 0.0005 % sulfur. If not, repeat 28.4.1 and 28.4.2.

28.4.4 Transfer two dried capsules of sulfur solution A, B, and C to preheated crucibles. Add approximately 1.0 g of pure iron, weighed to the nearest 5 mg, and approximately 1.5 g of accelerator to each crucible.

28.4.5 Treat each capsule as directed in 29.2 and 29.3 before proceeding to the next one.

28.4.6 Record the results of 28.4.5 and compare them to the theoretical sulfur values of solution A, B, and C. If they are not within 0.0003 % of the theoretical concentrations of sulfur in the test portions, refer to the manufacturer's instructions for checking the linearity of the system.

NOTE 9—Verify the calibration when: (1) a different lot of crucibles is used, (2) a different lot of accelerator is used, (3) the system has not been in use for 1 h, and (4) the oxygen supply has been changed. Verification should consist of analyzing at least one run of each calibrant. Recalibrate as necessary.

29. Procedure

29.1 Stabilize the furnace and analyzer as directed in Section 26. Transfer approximately 1.0 g of specimen, weighed to the nearest 1 mg, and approximately 1.5 g of accelerator to a preheated crucible. (See 24.2.)

29.2 Place the crucible on the furnace pedestal and raise the pedestal into position. Use crucible tongs to handle the preheated crucibles.

29.3 Refer to manufacturer's recommended procedure regarding entry of specimen weight and blank value. Start the analysis cycle.

NOTE 10—This procedure is for analysis of steel samples and a new blank must be determined using approximately 1.5 g of accelerator only. Refer to 62.3.

30. Calculation

30.1 Since most commercially available instruments calculate percent concentrations directly, including corrections for blank and sample weight, calculations by the analyst are not required.

NOTE 11—If the analyzer does not compensate for blank and sample weight values, then use the following formula:

$$\text{Sulfur, \%} = \frac{(A - B) \times C}{D} \quad (2)$$

where:

- A = DVM reading for specimen,
- B = DVM reading for blank,
- C = weight compensator setting, and
- D = specimen weight, g.

31. Precision and Bias⁷

31.1 *Precision*—Twenty-five laboratories participated in testing this method under the auspices of WG-3 of ISO Committee TC 17/SC 1 and obtained the data summarized in Table 4. All testing meets the requirements of Practice E173.

31.2 *Bias*—Information on the accuracy of this test method is incomplete at this time. The user is cautioned to verify by the use of certified reference materials, if available, that the accuracy of this test method is adequate for the contemplated use.

NITROGEN BY THE INERT GAS FUSION THERMAL CONDUCTIVITY TEST METHOD

32. Scope

32.1 This test method covers the determination of nitrogen (N) in concentrations from 0.0010 % to 0.2 % (Note 12).

⁷ Supporting data have been filed at ASTM International Headquarters and may be obtained by requesting Research Report RR:E01-1041.

TABLE 4 Statistical Information—Sulfur

Test Specimen	Sulfur Found, %	Repeatability (R_1 , Practice E173)	Reproducibility (R_2 , Practice E173)
Low alloy steel (JK 24, 0.0010 S)	0.0010	0.00045	0.00051
Stainless steel (NIST 348, 0.0020 S)	0.00198	0.0005	0.00064
Silicon steel (IRSID 114-1, 0.0037 S)	0.00322	0.00051	0.0007
Plain carbon steel (JSS 240-8, 0.0060 S)	0.00549	0.00055	0.00099
Stainless steel (JSS 652-7, 0.0064 S)	0.00615	0.00084	0.00087