

Second edition
2017-05

Corrected version
2019-08

**Sterile hypodermic syringes for
single use —**

**Part 1:
Syringes for manual use**

Seringues hypodermiques stériles, non réutilisables —

Partie 1: Seringues pour utilisation manuelle

**iTeh STANDARD PREVIEW
(standards.iteh.ai)**

[ISO 7886-1:2017](https://standards.iteh.ai/catalog/standards/sist/bdcab366-f730-4ce1-9fe2-b34457582c71/iso-7886-1-2017)

<https://standards.iteh.ai/catalog/standards/sist/bdcab366-f730-4ce1-9fe2-b34457582c71/iso-7886-1-2017>



Reference number
ISO 7886-1:2017(E)

© ISO 2017

iTeh STANDARD PREVIEW
(standards.iteh.ai)

ISO 7886-1:2017

<https://standards.iteh.ai/catalog/standards/sist/bdcab366-f730-4ce1-9fe2-b34457582c71/iso-7886-1-2017>



COPYRIGHT PROTECTED DOCUMENT

© ISO 2017

All rights reserved. Unless otherwise specified, or required in the context of its implementation, no part of this publication may be reproduced or utilized otherwise in any form or by any means, electronic or mechanical, including photocopying, or posting on the internet or an intranet, without prior written permission. Permission can be requested from either ISO at the address below or ISO's member body in the country of the requester.

ISO copyright office
CP 401 • Ch. de Blandonnet 8
CH-1214 Vernier, Geneva
Phone: +41 22 749 01 11
Fax: +41 22 749 09 47
Email: copyright@iso.org
Website: www.iso.org

Published in Switzerland

Contents

	Page
Foreword.....	v
Introduction.....	vii
1 Scope	1
2 Normative references	1
3 Terms and definitions	1
4 Nomenclature	3
5 General requirements	5
6 Extraneous matter	5
6.1 General.....	5
6.2 Limits for acidity or alkalinity.....	5
6.3 Limits for extractable metals.....	5
7 Lubricant	6
8 Tolerance on graduated capacity	6
9 Graduated scale	7
9.1 Scale.....	7
9.2 Numbering of scales.....	8
9.3 Overall length of scale to nominal capacity line.....	8
9.4 Position of scale.....	9
10 Barrel	9
10.1 Dimensions.....	9
10.2 Barrel flanges.....	9
11 Plunger stopper/plunger assembly	9
11.1 Design.....	9
12 Nozzle	10
12.1 Conical fitting.....	10
12.2 Position of nozzle on end of barrel.....	10
12.3 Nozzle lumen.....	10
13 Performance	10
13.1 Dead space.....	10
13.2 Freedom from air and liquid leakage past plunger stopper.....	10
13.3 Force to operate the piston.....	10
13.4 Fit of plunger stopper/plunger in barrel.....	10
14 Packaging	11
14.1 Unit packaging and self-contained syringe units.....	11
14.1.1 Unit packaging.....	11
14.1.2 Self-contained syringe units.....	11
14.2 Multiple unit pack.....	11
14.3 User packaging.....	11
15 Information supplied by the manufacturer	12
15.1 General.....	12
15.2 Syringes.....	12
15.2.1 General.....	12
15.2.2 Additional marking for self-contained syringe units.....	12
15.3 Unit packaging.....	12
15.4 Multiple unit packs.....	13
15.4.1 General.....	13
15.4.2 Multiple unit packs with self-contained syringes.....	13
15.5 User packaging.....	13

15.6	Storage container.....	14
15.7	Transport wrapping.....	14
Annex A (normative) Method for preparation of extracts.....		15
Annex B (normative) Test method for air leakage past syringe plunger stopper during aspiration, and for separation of plunger stopper and plunger.....		16
Annex C (normative) Method for determination of dead space.....		18
Annex D (normative) Test method for liquid leakage at syringe plunger stopper under compression.....		19
Annex E (informative) Test method for the determination of forces required to operate the piston.....		21
Annex F (informative) Test method for the quantity of silicone.....		25
Bibliography.....		28

iTeh STANDARD PREVIEW
(standards.iteh.ai)

[ISO 7886-1:2017](https://standards.iteh.ai/catalog/standards/sist/bdcab366-f730-4ce1-9fe2-b34457582c71/iso-7886-1-2017)

<https://standards.iteh.ai/catalog/standards/sist/bdcab366-f730-4ce1-9fe2-b34457582c71/iso-7886-1-2017>

Foreword

ISO (the International Organization for Standardization) is a worldwide federation of national standards bodies (ISO member bodies). The work of preparing International Standards is normally carried out through ISO technical committees. Each member body interested in a subject for which a technical committee has been established has the right to be represented on that committee. International organizations, governmental and non-governmental, in liaison with ISO, also take part in the work. ISO collaborates closely with the International Electrotechnical Commission (IEC) on all matters of electrotechnical standardization.

The procedures used to develop this document and those intended for its further maintenance are described in the ISO/IEC Directives, Part 1. In particular, the different approval criteria needed for the different types of ISO documents should be noted. This document was drafted in accordance with the editorial rules of the ISO/IEC Directives, Part 2 (see www.iso.org/directives).

Attention is drawn to the possibility that some of the elements of this document may be the subject of patent rights. ISO shall not be held responsible for identifying any or all such patent rights. Details of any patent rights identified during the development of the document will be in the Introduction and/or on the ISO list of patent declarations received (see www.iso.org/patents).

Any trade name used in this document is information given for the convenience of users and does not constitute an endorsement.

For an explanation on the voluntary nature of standards, the meaning of ISO specific terms and expressions related to conformity assessment, as well as information about ISO's adherence to the World Trade Organization (WTO) principles in the Technical Barriers to Trade (TBT) see the following URL: www.iso.org/iso/foreword.html.

This document was prepared by Technical committee ISO/TC 84, *Devices for administration of medicinal products and catheters*.

This second edition cancels and replaces the first edition (ISO 7886-1:1993), which has been technically revised. It also incorporates the Technical corrigendum ISO 7886-1:1993/Cor.1:1995.

The main changes to the previous edition are the following:

- a) clarified the Scope, e.g. excluding single-use syringes made of glass;
- b) added new Normative references;
- c) added new terms and definitions;
- d) clarified the drawing to illustrate the component of the syringe;
- e) included general requirements;
- f) revised test methods for syringes;
- g) revised the labelling requirement;
- h) clarified the type of lubricant for the different types of syringes;
- i) replaced Annex E (informative): Examples of test methods for incompatibility between syringes and injection fluids with [Annex E](#) (informative): Test method for the determination of forces required to operate the piston;
- j) added [Annex F](#) (informative): Test method for the quantity of silicone;
- k) informative annex on materials has been deleted.

A list of all parts in the ISO 7886 series can be found on the ISO website.

This corrected version of ISO 7886-1:2017 incorporates the following corrections:

- In the key to Figure E.1, item 2 was corrected to read "needle [1,2 mm (18 G) and approximately 40 mm length]";
- In the key to Figure E.1, item 3 was corrected to read " tubing [(2,7 ± 0,1) mm i.d. and (500 ± 5) mm in length with male and female Luer adapters at each end)]";
- In E.2.3, the value "(19,5 ± 0,5) cm" was changed to "(500 ± 5) mm".

iTeh STANDARD PREVIEW
(standards.iteh.ai)

ISO 7886-1:2017

<https://standards.iteh.ai/catalog/standards/sist/bdcab366-f730-4ce1-9fe2-b34457582c71/iso-7886-1-2017>

Introduction

The ISO 7886 series covers hypodermic syringes primarily intended for human use and provides performance and testing requirements. It permits broader variation in design so as not to limit innovation and methods of packaging. Its appearance and layout are consistent with other related standards which are designed to be more performance-based compared to design prescriptive.

General requirements as design guidelines for manufacturers are introduced in this document. Several limits for requirements which are historic based but confirmed in practice for many years have been kept.

Materials to be used for the construction and lubrication of sterile syringes for single use are not specified as their selection will depend to some extent upon the design, process of manufacture and sterilization method employed by individual manufacturers. The materials of the syringe should be compatible with injection fluids. If this is not the case, the attention of the user should be drawn to the exception by labelling on unit packaging. It is not practicable to specify a universally acceptable test method for incompatibility, as the only conclusive test is that an individual specific injection fluid is compatible with a specific syringe.

Manufacturers of pharmaceuticals use solvents in injectable preparations. Such solvents should be tested by the manufacturer of the injectable preparation for any possible incompatibility with the materials frequently used in syringe construction. If an incompatibility is identified, the injection fluid should be suitably labelled. The impossibility of testing any one injection fluid with all available syringes is recognized and it is strongly recommended that regulatory authorities and relevant trade associations should recognize the problem and take appropriate measures to assist manufacturers of injectable preparations.

Syringes should be manufactured and sterilized in accordance with recognized national or international codes of good manufacturing practice for medical devices.

The sampling plans for inspection selected for the ISO 7886 series are intended to verify the design at a high confidence level. The sampling plans for inspection do not replace the more general manufacturing quality systems requirements that appear in standards on quality systems, for example the ISO 9000 series and ISO 13485.

Manufacturers are expected to follow a risk-based approach and employ usability engineering during the design, development and manufacture of syringes.

Guidance on transition periods for implementing the requirements of ISO 7886 (all parts) is given in ISO/TR 19244.

iTeh STANDARD PREVIEW
(standards.iteh.ai)

ISO 7886-1:2017

<https://standards.iteh.ai/catalog/standards/sist/bdcab366-f730-4ce1-9fe2-b34457582c71/iso-7886-1-2017>

Sterile hypodermic syringes for single use —

Part 1: Syringes for manual use

1 Scope

This document specifies requirements and test methods for verifying the design of empty sterile single-use hypodermic syringes, with or without needle, made of plastic or other materials and intended for the aspiration and injection of fluids after filling by the end-users. This document does not provide requirements for lot release. The syringes are primarily for use in humans.

Sterile syringes specified in this document are intended for use immediately after filling and are not intended to contain the medicament for extended periods of time.

It excludes syringes for use with insulin (see ISO 8537), single-use syringes made of glass, syringes for use with power-driven syringe pumps, syringes pre-filled by the manufacturer, and syringes intended to be stored after filling (e.g. in a kit for filling by a pharmacist).

Hypodermic syringes without a needle specified in this document are intended for use with hypodermic needles specified in ISO 7864.

2 Normative references

The following documents are referred to in the text in such a way that some or all of their content constitutes requirements of this document. For dated references, only the edition cited applies. For undated references, the latest edition of the referenced document (including any amendments) applies.

ISO 15223-1:2016, *Medical devices — Symbols to be used with medical device labels, labelling and information to be supplied — Part 1: General requirements*

ISO 23908, *Sharps injury protection — Requirements and test methods — Sharps protection features for single-use hypodermic needles, introducers for catheters and needles used for blood sampling*

ISO 80369-7, *Small-bore connectors for liquids and gases in healthcare applications — Part 7: Connectors for intravascular or hypodermic applications*

3 Terms and definitions

For the purposes of this document, the following terms and definitions apply.

ISO and IEC maintain terminological databases for use in standardization at the following addresses:

- IEC Electropedia: available at <http://www.electropedia.org/>
- ISO Online browsing platform: available at <http://www.iso.org/obp>

3.1

nominal capacity

capacity of the syringe as designated by the manufacturer

EXAMPLE 1 ml, 5 ml, 50 ml

3.2

graduated capacity

volume of water, at 18 °C to 28 °C, expelled from the syringe when the fiducial line on the piston traverses a given scale interval or intervals

3.3

total graduated capacity

capacity of the syringe at the graduation line furthest from the zero graduation line

3.4

maximum usable capacity

capacity of the syringe when the piston is drawn back to its furthest functional position

3.5

fiducial line

leading edge on the plunger stopper that is in contact with and perpendicular to the syringe barrel and aligns with the zero marking on the syringe barrel when the piston is fully inserted

3.6

unit packaging

packaging which has direct contact with the device and maintains the sterility of the product

3.7

user packaging

packaging designed to contain one or more unit packages or self-contained syringe units

Note 1 to entry: Self-contained syringe units can be packed in multiple unit packs.

3.8

two-piece syringe

syringe assembly comprises the barrel and piston, whereas plunger and plunger stopper form one component made of the same material

3.9

three-piece syringe

syringe assembly includes the barrel and piston, whereas plunger and plunger stopper are two separate components of different materials

3.10

nozzle cap

sheath intended to physically protect the nozzle prior to use

3.11

plunger stopper

component connected to the leading end of the plunger and seals the open end of the syringe barrel

3.12

self-contained syringe

syringe with protective end caps [i.e. plunger cap, and nozzle cap or *needle cap* (3.17)] intended to maintain the sterility of the interior of the syringe

3.13

dead space

residual volume of fluid left in syringe when the *plunger stopper* (3.11) is fully depressed

3.14

multiple unit pack

multiple syringes packaged with a single seal that maintains the sterility of the product

STANDARD PREVIEW
(standards.iteh.ai)

ISO 7886-1:2017
<http://standards.iteh.ai/catalog/standards/sist/bdcab366-f730-4ce1-9fe2-b34457582c71/iso-7886-1-2017>

3.15**piston**

assembled component of plunger and *plunger stopper* ([3.11](#))

3.16**barrel flanges**

flanges that protrude from the barrel (also referred to as finger grips) to provide the user an ergonomic means of gripping the syringe during injection

3.17**needle cap or shield**

sheath intended to physically protect the needle prior to use

3.18**plunger**

device component which advances the *plunger stopper* ([3.11](#)) to deliver the medicinal product

4 Nomenclature

The nomenclature for the components of hypodermic syringes for single use is shown in [Figure 1](#).

iTeh STANDARD PREVIEW (standards.iteh.ai)

[ISO 7886-1:2017](#)

<https://standards.iteh.ai/catalog/standards/sist/bdcab366-f730-4ce1-9fe2-b34457582c71/iso-7886-1-2017>

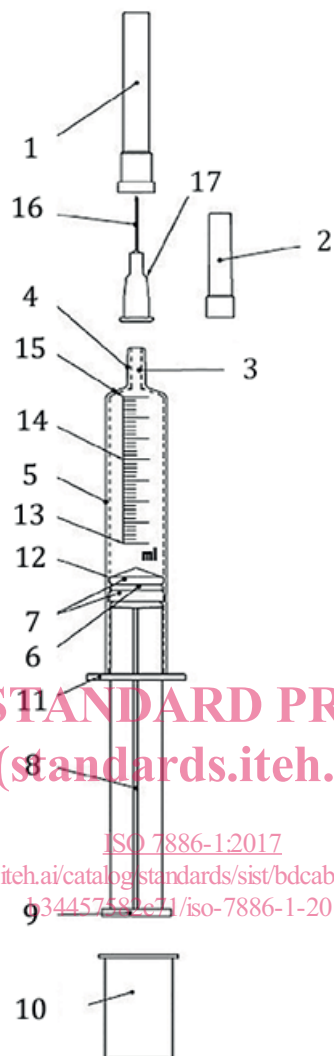

iTeh STANDARD PREVIEW
(standards.iteh.ai)

ISO 7886-1:2017

<https://standards.iteh.ai/catalog/standards/sist/bdcab366-f730-4ce1-9fe2-634457481e71/iso-7886-1-2017>

Key

- | | | | |
|---|--------------------------------|----|-------------------------------|
| 1 | needle cap or shield (if used) | 10 | plunger cap |
| 2 | nozzle cap | 11 | barrel flanges (finger grips) |
| 3 | nozzle lumen | 12 | fiducial line |
| 4 | nozzle | 13 | nominal capacity |
| 5 | barrel | 14 | graduation lines |
| 6 | plunger stopper (3-piece only) | 15 | zero line |
| 7 | seals | 16 | needle tube |
| 8 | plunger | 17 | hub |
| 9 | push-button | | |

NOTE The figure is intended to be illustrative of the components of a syringe. The plunger stopper/plunger assembly can or cannot be of integral construction and can or cannot incorporate more than one seal.

Figure 1 — Schematic representation of hypodermic syringe for single use