**Paints and varnishes — Determination
of pH value —**

**Part 2:
pH electrodes with ISFET technology**

Peintures et vernis — Détermination de la valeur pH —

Partie 2: Électrodes pH avec technique ISFET

**iTeh STANDARD PREVIEW
(standards.iteh.ai)**

ISO 19396-2:2017

<https://standards.iteh.ai/catalog/standards/sist/8ad4d80f-9f5c-433f-a417-2d3e0403aca6/iso-19396-2-2017>



iTeh STANDARD PREVIEW
(standards.iteh.ai)

ISO 19396-2:2017

<https://standards.iteh.ai/catalog/standards/sist/8ad4d80f-9f5c-433f-a417-2d3e0403aca6/iso-19396-2-2017>



COPYRIGHT PROTECTED DOCUMENT

© ISO 2017, Published in Switzerland

All rights reserved. Unless otherwise specified, no part of this publication may be reproduced or utilized otherwise in any form or by any means, electronic or mechanical, including photocopying, or posting on the internet or an intranet, without prior written permission. Permission can be requested from either ISO at the address below or ISO's member body in the country of the requester.

ISO copyright office
Ch. de Blandonnet 8 • CP 401
CH-1214 Vernier, Geneva, Switzerland
Tel. +41 22 749 01 11
Fax +41 22 749 09 47
copyright@iso.org
www.iso.org

Contents

| | Page |
|--|-----------|
| Foreword..... | iv |
| Introduction..... | v |
| 1 Scope..... | 1 |
| 2 Normative references..... | 1 |
| 3 Terms and definitions..... | 1 |
| 4 Principle..... | 5 |
| 5 Apparatus and materials..... | 5 |
| 6 Sampling..... | 8 |
| 7 Procedure..... | 9 |
| 7.1 Test conditions..... | 9 |
| 7.2 Calibration..... | 9 |
| 7.3 Number of determinations..... | 9 |
| 7.4 Measuring the pH value..... | 9 |
| 8 Evaluation..... | 9 |
| 9 Precision..... | 10 |
| 9.1 General..... | 10 |
| 9.2 Repeatability limit, r | 10 |
| 9.3 Reproducibility limit, R | 10 |
| 10 Test report..... | 10 |
| Annex A (informative) Determination of precision..... | 11 |
| Bibliography..... | 13 |

Foreword

ISO (the International Organization for Standardization) is a worldwide federation of national standards bodies (ISO member bodies). The work of preparing International Standards is normally carried out through ISO technical committees. Each member body interested in a subject for which a technical committee has been established has the right to be represented on that committee. International organizations, governmental and non-governmental, in liaison with ISO, also take part in the work. ISO collaborates closely with the International Electrotechnical Commission (IEC) on all matters of electrotechnical standardization.

The procedures used to develop this document and those intended for its further maintenance are described in the ISO/IEC Directives, Part 1. In particular the different approval criteria needed for the different types of ISO documents should be noted. This document was drafted in accordance with the editorial rules of the ISO/IEC Directives, Part 2 (see www.iso.org/directives).

Attention is drawn to the possibility that some of the elements of this document may be the subject of patent rights. ISO shall not be held responsible for identifying any or all such patent rights. Details of any patent rights identified during the development of the document will be in the Introduction and/or on the ISO list of patent declarations received (see www.iso.org/patents).

Any trade name used in this document is information given for the convenience of users and does not constitute an endorsement.

For an explanation on the voluntary nature of standards, the meaning of ISO specific terms and expressions related to conformity assessment, as well as information about ISO's adherence to the World Trade Organization (WTO) principles in the Technical Barriers to Trade (TBT) see the following URL: www.iso.org/iso/foreword.html. (standards.iteh.ai)

This document was prepared by Technical Committee ISO/TC 35, *Paints and varnishes*, Subcommittee SC 9, *General test methods for paints and varnishes*.

<https://standards.iteh.ai/catalog/standards/sist/8ad4d80f-9f5c-433f-a417-2d3b2492760c/iso-19396-2-2017>

A list of all parts in the ISO 19396 series can be found on the ISO website.

Introduction

The pH value of aqueous products is of decisive importance for the product properties and durability.

iTeh STANDARD PREVIEW (standards.iteh.ai)

[ISO 19396-2:2017](https://standards.iteh.ai/catalog/standards/sist/8ad4d80f-9f5c-433f-a417-2d3e0403aca6/iso-19396-2-2017)

<https://standards.iteh.ai/catalog/standards/sist/8ad4d80f-9f5c-433f-a417-2d3e0403aca6/iso-19396-2-2017>

iTeh STANDARD PREVIEW
(standards.iteh.ai)

ISO 19396-2:2017

<https://standards.iteh.ai/catalog/standards/sist/8ad4d80f-9f5c-433f-a417-2d3e0403aca6/iso-19396-2-2017>

Paints and varnishes — Determination of pH value —

Part 2: pH electrodes with ISFET technology

1 Scope

This document specifies a method for measuring the pH value of dispersions and coating materials using pH electrodes with ion-sensitive field-effect transistor (ISFET) technology. ISO 19396-1 specifies a method for measuring the pH value using pH electrodes with a glass membrane.

2 Normative references

The following documents are referred to in the text in such a way that some or all of their content constitutes requirements of this document. For dated references, only the edition cited applies. For undated references, the latest edition of the referenced document (including any amendments) applies.

ISO 1513, *Paints and varnishes — Examination and preparation of test samples*

ISO 4618, *Paints and varnishes — Terms and definitions*

ISO 15528, *Paints, varnishes and raw materials for paints and varnishes — Sampling*

ISO 80000-9:2009, *Quantities and units — Part 9: Physical chemistry and molecular physics*

<https://standards.iteh.ai/catalog/standards/sist/8ad4d80f-9f5c-433f-a417-2d3e0403aca6/iso-19396-2-2017>

3 Terms and definitions

For the purpose of this document, the terms and definitions given in ISO 4618 and ISO 80000-9 and the following apply.

ISO and IEC maintain terminological databases for use in standardization at the following addresses:

— IEC Electropedia: available at <http://www.electropedia.org/>

— ISO Online browsing platform: available at <http://www.iso.org/obp>

3.1

pH

measure for the acidic or basic reaction of an aqueous solution or polymer dispersion

Note 1 to entry: Notation of pH: the p and the H are vertically on one line. The same is valid for pOH.

Note 2 to entry: The acidic reaction is determined by the activity of the existing “hydrogen ions”. The basic reaction is determined by the activity of the existing hydroxide ions. The direct relationship between the activities of the “hydrogen ions” and the hydroxide ions is described by the ionic product of the water.

[SOURCE: ISO 19396-1:2017, 3.1]

3.2

pH value

decadal logarithm of the hydrogen ion activity multiplied with (−1)

$$\text{pH} = \text{p}a_{\text{H}^+} = -\lg \left(\frac{a_{\text{H}^+}}{m^0} \right) = -\lg \left(\frac{m_{\text{H}^+} \cdot \gamma_{m,\text{H}^+}}{m^0} \right)$$

ISO 19396-2:2017(E)

with $a_{\text{H}^+} = m_{\text{H}^+} \cdot \gamma_{m,\text{H}^+}$

where

a_{H^+} is the activity of the hydrogen ion, in mol/kg;

m^0 is the standard molality (1 mol/kg);

γ_{m,H^+} is the activity coefficient of the hydrogen ion;

m_{H^+} is the molality of the hydrogen ion, in mol/kg.

Note 1 to entry: The pH value is not measurable as a measure of a single ion activity. Therefore, pH (PS) values of solutions of primary reference material (PS, en: Primary Standard) are determined, which are approximate to it and can be attributed to it. This is based on a worldwide agreement; see ISO 80000-9:2009, Annex C.

[SOURCE: ISO 19396-1:2017, 3.2]

3.3

ISFET electrode

combined pH electrode with ISFET technology

potentiometric cell providing a voltage which depends on the *pH value* (3.2) of the measuring medium

Note 1 to entry: One of the two electrochemical cells is the ISFET; the second is a reference electrode.

Note 2 to entry: An integrated temperature sensor is recommended (see [Figure 1](#)).

ISO 19396-2:2017
<https://standards.iteh.ai/catalog/standards/sist/8ad4d80f-9f5c-433f-a417-2d3e0403aca6/iso-19396-2-2017>

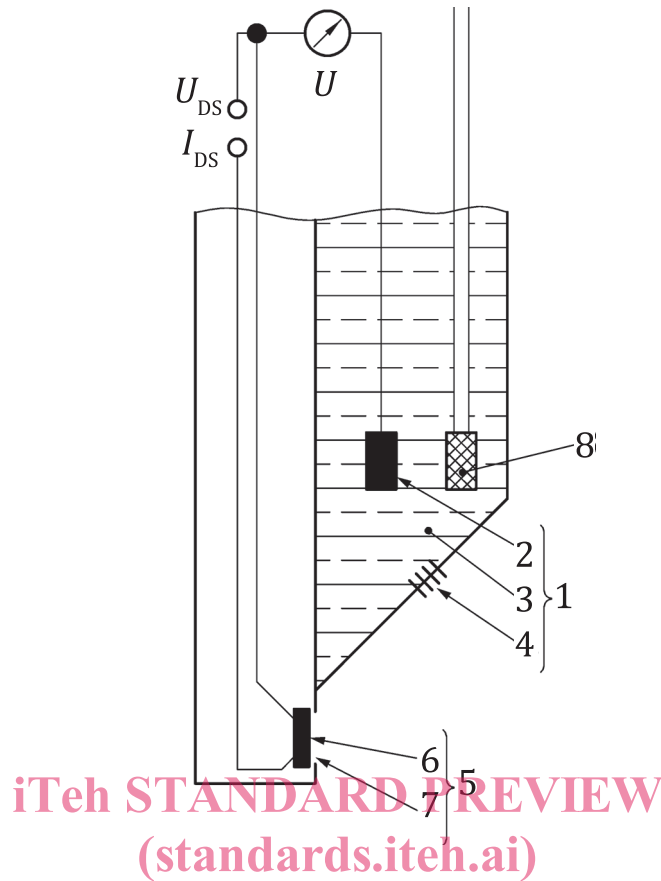

Key

- | | | | |
|---|---|---|---|
| 1 | reference electrode, consisting of 2, 3 and 4 | 7 | opening to the measuring medium (gate) |
| 2 | reference element | 8 | temperature sensor |
| 3 | reference electrolyte | | U_{DS} pH proportional voltage |
| 4 | diaphragm | | U_{DS} voltage receiver/sender (drain/source) |
| 5 | pH measuring electrode, consisting of 6 and 7 | | I_{DS} current receiver/sender (drain/source) |
| 6 | ISFET (see Figure 4) | | |

Figure 1 — Design of an ISFET electrode (schematic diagram)

3.4 reference electrode

electrode providing a constant potential which is independent from the *pH value* (3.2) of the measuring medium

Note 1 to entry: At present, the most commonly used type is the silver/silver chloride reference electrode, whose potential is stabilized by a constant concentration of potassium chloride (KCl) in the *reference electrolyte* (3.6).

[SOURCE: ISO 19396-1:2017, 3.5]

3.5 reference element

galvanic cell which dips into the *reference electrolyte* (3.6) and transmits the reference potential to the pH meter

[SOURCE: ISO 19396-1:2017, 3.6, modified — Note 1 to entry has been deleted.]

**3.6
reference electrolyte**

aqueous salt solution (generally potassium chloride solution), whose chloride ion activity determines the potential of the *reference electrode* (3.4)

Note 1 to entry: At the *diaphragm* (3.7), the reference electrolyte has contact with the measuring solution. Potassium chloride solution is used as reference electrolyte, because K⁺ ions and Cl⁻ ions have almost the same ion mobility and, therefore, only slight diffusion potentials result.

[SOURCE: ISO 19396-1:2017, 3.7, modified — Note 2 to entry has been deleted.]

**3.7
diaphragm**

permeable material in the sides of the casing of *reference electrodes* (3.4), which enables the electrolytic contact between *reference electrolytes* (3.6) and measuring solution and simultaneously impedes the exchange of electrolyte

[SOURCE: ISO 19396-1:2017, 3.8, modified — Note 1 to entry has been deleted.]

**3.8
measuring electrode
ion-sensitive field-effect transistor
ISFET**

electrode providing a pH proportional signal with a suitable electronic circuit

**3.9
temperature compensation**

compensation of the temperature-dependent measuring signal only of the *buffer solutions* (3.13) with known temperature dependency

Note 1 to entry: By this, the temperature dependency of the *pH value* (3.2) of the measuring medium cannot be compensated. Therefore, the temperature is always recorded together with the pH value.

[SOURCE: ISO 19396-1:2017, 3.11]

**3.10
theoretical slope**

k
change of the voltage of the pH electrode with temperature

$$k = -\frac{R \cdot T}{F} \cdot \ln 10 = -2,303 \cdot \frac{R \cdot T}{F}$$

where

T is the thermodynamic temperature, in Kelvin (measuring temperature, in °C + 273,15 °C);

R is the gas constant 8,314 J mol⁻¹ K⁻¹;

F is the Faraday constant 96 485 C mol⁻¹.

Note 1 to entry: At 23 °C, *k* = -58,57 mV.

[SOURCE: ISO 19396-1:2017, 3.12]

3.11 practical slope

k'

slope of a pH electrode, which is obtained by measuring the pH proportional voltages of the pH electrode in at least two reference *buffer solutions* (3.13)

$$k' = \frac{\Delta U}{\Delta \text{pH}}$$

Note 1 to entry: The slope obtained during calibration is a characteristic for the quality of the pH electrode.

[SOURCE: ISO 19396-1:2017, 3.13]

3.12 zero point

pH value (3.2), pH_0 , of a pH electrode, for which the pH proportional voltage of the pH electrode is $U = 0$ mV at a given temperature

Note 1 to entry: The zero point for the *ISFET electrode* (3.3) is set by calibrating the offset voltage.

[SOURCE: ISO 19396-1:2017, 3.14, modified — Note 1 to entry has been replaced, Note 2 to entry has been deleted.]

3.13 buffer solution

solution with a *pH value* (3.2) of known measurement uncertainty

Note 1 to entry: The buffer solution is used for calibration and adjustment of pH meters. Buffer solutions have a pH value that is largely non-sensitive to dilution and acid or alkali addition.

[SOURCE: ISO 19396-1:2017, 3.15]

ISO 19396-2:2017

<https://standards.iteh.ai/catalog/standards/sist/8ad4d80f-9f5c-433f-a417-2d3e0403aca6/iso-19396-2-2017>

3.17 stability of measured value

change of the measurement signal over time, dU/dt , under unchanged measurement conditions

Note 1 to entry: The stability of measured value is specified in accordance with the reproducibility requirement of the measurement.

[SOURCE: ISO 19396-1:2017, 3.16]

4 Principle

This document comprises the description of the ISFET electrode, its calibration and cleaning, as well as the procedure of pH measurement. The specified method and measuring conditions are based on the results of an interlaboratory test (see also [Annex A](#)).

5 Apparatus and materials

Ordinary laboratory and glass apparatus, together with the following:

5.1 pH measuring apparatus.

A pH measuring apparatus (see [Figure 2](#)) for pH measurement of polymer dispersions and coating materials consists of a pH meter suitable for ISFET electrodes, an ISFET electrode, at least two buffer solutions, containers for the buffer solutions and the material to be measured. For cleaning the ISFET electrode, a spray bottle with deionized water or a suitable cleaning solution and a small brush are recommended. In addition, it can be helpful to use a stand, a stirring tool, a thermostat, as well as data recording and analysis systems.