



Designation: ~~C215—02~~ Designation: C 215 – 08

Standard Test Method for Fundamental Transverse, Longitudinal, and Torsional Resonant Frequencies of Concrete Specimens¹

This standard is issued under the fixed designation C 215; the number immediately following the designation indicates the year of original adoption or, in the case of revision, the year of last revision. A number in parentheses indicates the year of last reapproval. A superscript epsilon (ϵ) indicates an editorial change since the last revision or reapproval.

This standard has been approved for use by agencies of the Department of Defense.

1. Scope*

1.1 This test method covers measurement of the fundamental transverse, longitudinal, and torsional resonant frequencies of concrete prisms and cylinders for the purpose of calculating dynamic Young's modulus of elasticity, the dynamic modulus of rigidity (sometimes designated as "the modulus of elasticity in shear"), and dynamic Poisson's ratio.

~~1.2 Values in SI units are the standard.~~

1.2 The values stated in SI units are to be regarded as standard. No other units of measurement are included in this standard.

1.3 *This standard does not purport to address all of the safety concerns, if any, associated with its use. It is the responsibility of the user of this standard to establish appropriate safety and health practices and determine the applicability of regulatory limitations prior to use.*

2. Referenced Documents

2.1 *ASTM Standards:*²

C 31/C 31M Practice for Making and Curing Concrete Test Specimens in the Field

C 42/C 42M Test Method for Obtaining and Testing Drilled Cores and Sawed Beams of Concrete

C 125 Terminology Relating to Concrete and Concrete Aggregates

C 192/C 192M Practice for Making and Curing Concrete Test Specimens in the Laboratory

C 469 Test Method for Static Modulus of Elasticity and Poisson's Ratio of Concrete in Compression

C 670 Practice for Preparing Precision and Bias Statements for Test Methods for Construction Materials

E 1316 Terminology for Nondestructive Examinations

3. Terminology

3.1 *Definitions*—Refer to Terminology C 125 and the section related to ultrasonic examination in Terminology E 1316 for definitions of terms used in this test method.

4. Summary of Test Method

4.1 The fundamental resonant frequencies are determined using one of two alternative procedures: (1) the forced resonance method or (2) the impact resonance method. Regardless of which testing procedure is selected, the same procedure is to be used for all specimens of an associated series.

4.2 In the forced resonance method, a supported specimen is forced to vibrate by an electro-mechanical driving unit. The specimen response is monitored by a lightweight pickup unit on the specimen. The driving frequency is varied until the measured specimen response reaches a maximum amplitude. The value of the frequency causing maximum response is the resonant frequency of the specimen. The fundamental frequencies for the three different modes of vibration are obtained by proper location of the driver and the pickup unit.

4.3 In the impact resonance method, a supported specimen is struck with a small impactor and the specimen response is measured by a lightweight accelerometer on the specimen. The output of the accelerometer is recorded. The fundamental frequency of vibration is determined by using digital signal processing methods or counting zero crossings in the recorded waveform. The

¹ This test method is under the jurisdiction of ASTM Committee C09 on Concrete and Concrete Aggregates and is the direct responsibility of Subcommittee C09.64 on Nondestructive and In-Place Testing.

Current edition approved Dec. 10, 2002. Published February 2003. Originally approved in 1947. Last previous edition approved in 1997 as C215-97^{e1}.

Current edition approved Oct. 1, 2008. Published November 2008. Originally approved in 1947. Last previous edition approved in 2002 as C 215 – 02.

² Annual Book of ASTM Standards, Vol 04.02.

³ For referenced ASTM standards, visit the ASTM website, www.astm.org, or contact ASTM Customer Service at service@astm.org. For Annual Book of ASTM Standards volume information, refer to the standard's Document Summary page on the ASTM website.

*A Summary of Changes section appears at the end of this standard.

fundamental frequencies for the three different modes of vibration are obtained by proper location of the impact point and the accelerometer.

5. Significance and Use

5.1 This test method is intended primarily for detecting significant changes in the dynamic modulus of elasticity of laboratory or field test specimens that are undergoing exposure to weathering or other types of potentially deteriorating influences.

5.1 This test method is intended primarily for detecting significant changes in the dynamic modulus of elasticity of laboratory or field test specimens that are undergoing exposure to weathering or other types of potentially deteriorating influences. The test method may also be used to monitor the development of dynamic elastic modulus with increasing maturity of test specimens.

5.2 The value of the dynamic modulus of elasticity obtained by this test method will, in general, be greater than the static modulus of elasticity obtained by using Test Method C 469. The difference depends, in part, on the strength level of the concrete.

5.3 The conditions of manufacture, the moisture content, and other characteristics of the test specimens (see section on Test Specimens) materially influence the results obtained.

5.4 Different computed values for the dynamic modulus of elasticity may result from widely different resonant frequencies of specimens of different sizes and shapes of the same concrete. Therefore, it is not advisable to compare results from specimens of different sizes or shapes.

6. Apparatus

6.1 Forced Resonance Apparatus (Fig. 1):

6.1.1 *Driving Circuit*—The driving circuit shall consist of a variable frequency audio oscillator, an amplifier, and a driving unit. The oscillator shall be calibrated to read within $\pm 2\%$ of the true frequency over the range of use (about 100 to 10 000 Hz). The combined oscillator and amplifier shall be capable of delivering sufficient power output to induce vibrations in the test specimen at frequencies other than the fundamental and shall be provided with a means for controlling the output. The driving unit for creating the vibration in the specimen shall be capable of handling the full power output of the oscillator and amplifier. The driving unit is used in contact with the test specimen or separated from the specimen by an air gap. When the test specimen is contact-driven, the vibrating parts of the driving unit shall be small in mass compared with that of the specimen. The oscillator and amplifier shall be capable of producing a voltage that does not vary more than $\pm 20\%$ over the frequency range and, in combination with the driving unit, shall be free from spurious resonances that will be indicated in the output.

NOTE 1—It is recommended that the calibration of the variable frequency audio oscillator be checked periodically against signals transmitted by the National Institute of Standards and Technology radio station WWV, or against suitable electronic equipment such as a frequency counter, the calibration of which has been previously checked and found to be adequate.

6.1.2 *Pickup Circuit*—The pickup circuit shall consist of a pickup unit, an amplifier, and an indicator. The pickup unit shall generate a voltage proportional to the displacement, velocity, or acceleration of the test specimen, and the vibrating parts shall be small in mass compared with the mass of the test specimen. The pickup unit shall be free from spurious resonances in the normal operating range. Either a piezoelectric or magnetic pickup unit meeting these requirements is acceptable. The amplifier shall have a controllable output of sufficient magnitude to actuate the indicator. The indicator shall consist of a voltmeter, milliammeter, or a real-time graphic display such as an oscilloscope or a data acquisition system with monitor (see Note 2).

NOTE 2—For routine testing of specimens whose fundamental frequency may be anticipated within reasonable limits, a meter-type indicator is satisfactory and may be more convenient to use than an oscilloscope or computer monitor. It is, however, strongly recommended that whenever feasible a graphic display be provided for supplementary use or to replace the meter-type indicator. The use of a graphic display as an indicator may be necessary when specimens are to be tested for which the fundamental frequency range is unpredictable. The graphic display is valuable also for checking the equipment for drift and for use in the event that it should be desired to use the equipment for certain other purposes than those specifically contemplated by this test method.

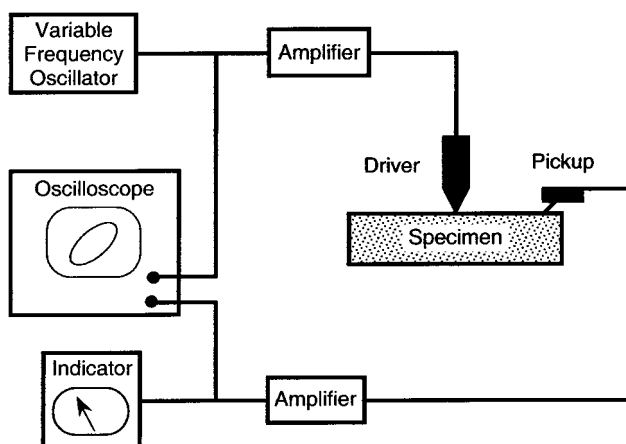

FIG. 1 Schematic of Apparatus for Forced Resonance Test

6.1.3 *Specimen Support*—The support shall permit the specimen to vibrate freely (Note 3). The location of the nodal points for the different modes of vibration are described in Notes 4, 5, and 6. The support system shall be dimensioned so that its resonant frequency falls outside the range of use (from 100 to 10 000 Hz).

NOTE 3—This may be accomplished by placing the specimen on soft rubber supports located near the nodal points or on a thick pad of sponge rubber.

6.2 *Impact Resonance Apparatus* (Fig. 2):

6.2.1 *Impactor*—~~The impactor shall be made of metal or rigid plastic and the mass of the head shall be 0.11 ± 0.02 kg. The striking end of the impactor shall have a spherical shape with a diameter of 6 ± 1 mm.~~ The impactor shall be made of metal or rigid plastic and shall produce an impact duration that is sufficiently short to excite the highest resonant frequency to be measured. The manufacturer shall indicate the maximum resonant frequency that can be excited when the impactor strikes a concrete specimen with surfaces formed by a metal or plastic mold.

NOTE 4—A 19 mm diameter solid steel ball mounted on a thin rod to produce a hammer is capable of exciting resonant frequencies up to about 10 kHz when impacting a smooth concrete surface. A 110 g steel ball peen hammer may act similarly. Larger steel balls will reduce the maximum resonant frequencies that can be excited.

6.2.2 *Sensor*—The sensor shall be a piezoelectric accelerometer with a mass less than 30 g and having an operating frequency range from 100 to 10 000 Hz. The resonant frequency of the accelerometer shall be at least two times the maximum operating frequency.

6.2.3 *Frequency Analyzer*—Determine the frequency of the specimen vibration by using either a digital waveform analyzer or a frequency counter to analyze the signal measured by the sensor. The waveform analyzer shall have a sampling rate of at least 20 kHz and shall record at least 1024 points of the waveform. The frequency counter shall have an accuracy of ± 1 % over the range of use.

6.2.4 *Specimen Support*—Support shall be provided as specified in 6.1.3 for the forced resonance method.

7. Test Specimens

7.1 *Preparation*—Make the cylindrical or prismatic test specimens in accordance with Practice C 192/C 192M, Practice C 31/C 31M, Test Method C 42/C 42M, or other specified procedures.

7.2 *Measurement of Mass and Dimensions*—Determine the mass and average length of the specimens within ± 0.5 %. Determine the average cross-sectional dimensions within ± 1 %.

7.3 *Limitations on Dimensional Ratio*—Specimens having either small or large ratios of length to maximum transverse direction are frequently difficult to excite in the fundamental mode of vibration. Best results are obtained when this ratio is between 3 and 5. For application of the formulas in this test method, the ratio must be at least 2.

8. Determination of Resonant Frequencies—Forced Resonance Method

8.1 *Transverse Frequency:*

8.1.1 Support the specimen so that it is able to vibrate freely in the transverse mode (Note 4>Note 5). Position the specimen and driver so that the driving force is perpendicular to the surface of the specimen. Locate the driving unit at the approximate middle of the specimen. Place the pickup unit on the specimen so that the direction of pickup sensitivity coincides with the vibration direction, that is, the transverse direction (see Fig. 3a). Position the pickup near one end of the specimen. It is permissible to position the driver on the vertical face so that the specimen vibrates perpendicular to the direction shown in Fig. 3a.

8.1.2 Force the test specimen to vibrate at varying frequencies. At the same time, observe the indication of the amplified output of the pickup. Record the fundamental transverse frequency of the specimen, which is the frequency at which the indicator shows the maximum reading and observation of nodal points indicates fundamental transverse vibration (Note 4>Note 5). Adjust the amplifiers in the driving and pickup circuits to provide a satisfactory indication. To avoid distortion, maintain the driving force as low as is feasible for good response at resonance.

NOTE 4—For 5—For fundamental transverse vibration, the nodal points are located 0.224 of the length of the specimen from each end (approximately the quarter points). Vibrations are a maximum at the ends, approximately three fifths of the maximum at the center, and zero at the nodal points; therefore, movement of the pickup along the length of the specimen will inform the operator whether the vibrations observed in the indicator are from the specimen vibrating in its fundamental transverse mode. An oscilloscope may also be used to determine whether the specimen is vibrating in its fundamental

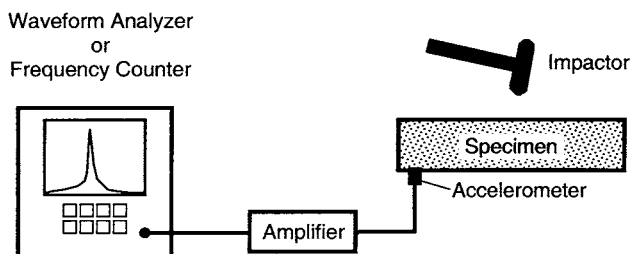

FIG. 2 Schematic of Apparatus for Impact Resonance Test

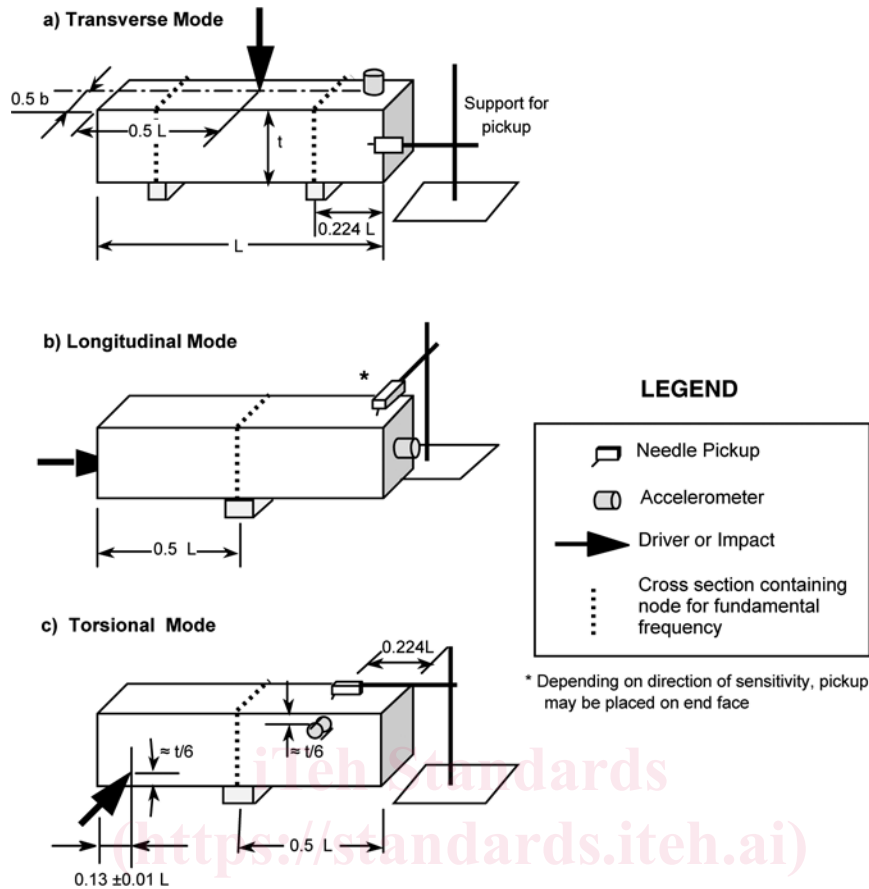

FIG. 3 Locations of Driver (or Impact) and Needle Pickup (or Accelerometer)

transverse mode. The driver signal is connected to the horizontal sweep and the pickup signal is connected to the vertical sweep of the oscilloscope. When the pickup is located at the end of the specimen, which is vibrating in its fundamental transverse mode, the oscilloscope will display an inclined elliptical pattern. When the pickup is placed at a node, the oscilloscope displays a horizontal line. When the pickup is placed at the center of the specimen, the display will be an elliptical pattern but inclined in the opposite direction to when the pickup was placed at the end of the specimen. The oscilloscope can also be used to verify that the driving frequency is the fundamental resonant frequency. Resonance can occur when the driving frequency is a fraction of the fundamental frequency. In this case, however, the oscilloscope pattern will not be an ellipse.

8.2 Longitudinal Frequency:

8.2.1 Support the specimen so that it is able to vibrate freely in the longitudinal mode (Note 5 Note 6). Position the specimen and driver so that the driving force is perpendicular to and approximately at the center of one end surface of the specimen. Place the pickup unit on the specimen so that the direction of pickup sensitivity coincides with the vibration direction, that is, the longitudinal axis of the specimen (see Fig. 3b).

8.2.2 Force the test specimen to vibrate at varying frequencies. At the same time, observe the indication of the amplified output of the pickup. Record the fundamental longitudinal frequency of the specimen, which is the frequency at which the indicator shows the maximum reading and observation of the nodal point indicates fundamental longitudinal vibration (Note 5 Note 6).

NOTE 5—For 6—For the fundamental longitudinal mode, there is one node at the center of length of the specimen. Vibrations are a maximum at the ends.

8.3 Torsional Frequency:

8.3.1 Support the specimen so that it is able to vibrate freely in the torsional mode (Note 6 7). Position the specimen and driver so that the driving force is perpendicular to the surface of the specimen. For prismatic specimens, locate the driving unit near the upper or lower edge of the specimen at a distance from the end that is between 0.10 and 0.12 0.13 ± 0.01 of the length of the specimen and approximately $\frac{1}{6}$ of the depth of the specimen from the edge (see Fig. 3c). For cylindrical specimens, locate the driving unit above or below the mid-line of the cylinder. Place the pickup unit on the surface of the specimen at a position on the opposite end that coincides with the node point for fundamental transverse vibration (see Fig. 3a). Position the pickup so that the direction of pickup sensitivity coincides with the vibration direction, that is, perpendicular to the longitudinal axis of the specimen.

8.3.2 Force the test specimen to vibrate at varying frequencies. At the same time, observe the indication of the amplified output of the pickup. Record the fundamental torsional frequency of the specimen, which is the frequency at which the indicator shows the maximum reading and observation of the nodal point indicates fundamental torsional vibration (Note 6 Note 7).