



Designation: ~~C1540-04~~ Designation: C 1540 – 08

Standard Specification for Heavy Duty Shielded Couplings Joining Hubless Cast Iron Soil Pipe and Fittings¹

This standard is issued under the fixed designation C 1540; the number immediately following the designation indicates the year of original adoption or, in the case of revision, the year of last revision. A number in parentheses indicates the year of last reapproval. A superscript epsilon (ϵ) indicates an editorial change since the last revision or reapproval.

1. Scope

1.1 This specification covers the evaluating of the performance of heavy duty shielded couplings to join hubless cast iron soil pipe and fittings.

1.2 Couplings covered by this standard shall have minimum dimensions as found in Table 1 and Fig. 1 of this standard.

~~1.3 The values stated in inch-pound units are to be regarded as the standard. The SI units given in parentheses are for information only.~~

1.3 The values stated in inch-pound units are to be regarded as standard. The values given in parentheses are mathematical conversions to SI units that are provided for information only and are not considered standard.

1.4 The committee with jurisdiction over this standard is aware of comparable standards published by other organizations, namely Cast Iron Soil Pipe Institute specification CISPI 310 and Factory Mutual Research standard FM 1680.

1.5 The following precautionary caveat pertains only to the test method portion, Section 7, of this specification. *This standard does not purport to address all of the safety concerns, if any, associated with its use. It is the responsibility of the user of this standard to establish appropriate safety and health practices and determine the applicability of regulatory limitations prior to use.*

2. Referenced Documents

2.1 ASTM Standards:²

~~A 240 Specification for Stainless and Heat-Resisting Chromium-Nickel Steel Plate, Sheet, and Strip 240/A 240M Specification for Chromium and Chromium-Nickel Stainless Steel Plate, Sheet, and Strip for Pressure Vessels and for General Applications~~

~~A 493 Specification for Stainless Wire and Wire Rods for Cold Heading and Cold Forging Specification for Stainless Steel Wire and Wire Rods for Cold Heading and Cold Forging~~

~~A 644 Terminology Relating to Iron Castings~~

~~A 888 Specification for Hubless Cast Iron Soil Pipe and Fittings for Sanitary, Storm Sanitary and Storm Drain, Waste, and Vent Piping Applications~~

~~C 564 Specification for Rubber Gaskets for Cast Iron Soil Pipe and Fittings~~

~~€717 Terminology of Building Seals and Sealants Specification for Rubber Gaskets for Cast Iron Soil Pipe and Fittings~~

2.2 CISPI Standards:

CISPI-301 Specification for Hubless Cast Iron Soil Pipe and Fittings for Sanitary and Storm Drain, Waste and Vent Piping Applications

CISPI-310 Specification for coupling for use in Connection with Hubless Cast Iron Soil Pipe and Fittings for Sanitary and Storm Drain, Waste and Vent Piping Applications

FM 1680 Approval Standard Couplings used in Hubless Cast Iron Systems for Drain, Waste or Vent Systems above or below ground Industrial, Commercial, and Residential

3. Terminology

3.1 Definitions:

3.1.1 Definitions of the following terms used in this specification are found in Terminology ~~€717~~ A 644.

3.2 Definitions of Terms Specific to This Standard:

3.2.1 *center stop, n*—an integral part of the gasket centered on the axial length of the gasket intended to limit the insertion depth of the pipe to be coupled.

¹ This specification is under the jurisdiction of ASTM Committee A04 on Iron Castings and is the direct responsibility of Subcommittee A04.75 on Gaskets and Couplings/Coupling for Plumbing and Sewer Piping.

Current edition approved ~~May~~ Oct. 1, 2004-2008. Published ~~August 2004~~ November 2008. Originally approved in 2002. Last previous edition approved in ~~2002~~ 2004 as C 1540 – 024.

² For referenced ASTM standards, visit the ASTM website, www.astm.org, or contact ASTM Customer Service at service@astm.org. For *Annual Book of ASTM Standards* volume information, refer to the standard's Document Summary page on the ASTM website.

TABLE 1

Nominal Pipe Size	Coupling Width
1½ to 4 in. (38 to 100 mm)	3 in. (76 mm) Minimum Width
5 to 10 in. (127 to 254 mm)	4 in. (100 mm) Minimum Width
12 to 15 in. (305 to 381 mm)	5½ in. (140 mm) Minimum Width

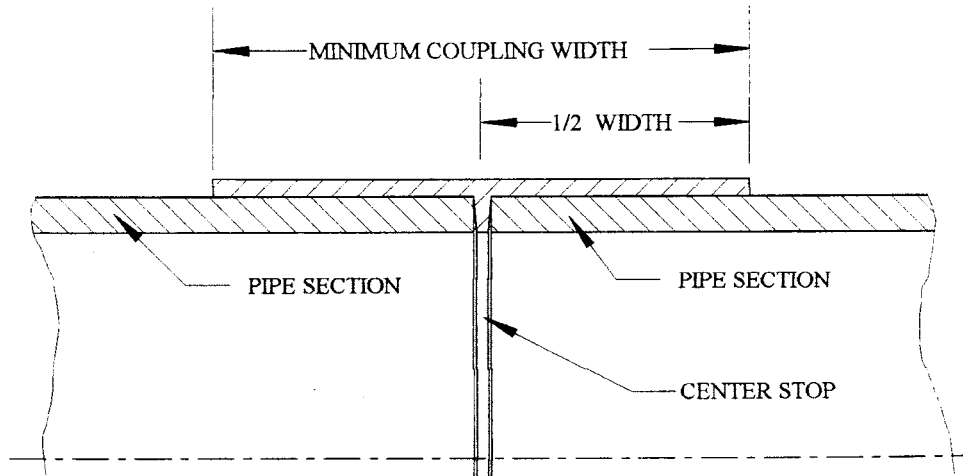

FIG. 1 Typical Center Stop Detail

- 3.2.2 *clamp assembly, n*—that portion of the coupling excluding the gasket.
- 3.2.3 *coupling, n*—the complete assembly.
- 3.2.4 *fitting, n*—parts of a pipeline other than straight pipes, valves, or couplings.
- 3.2.5 *gasket, n*—the elastomeric portion of the coupling.
- 3.2.6 *heavy duty coupling, n*—a shielded coupling that has dimensions not less than those detailed in Table 1 and Fig. 1.
- 3.2.7 *joint, n*—the point of assembly consisting of the coupling and the joined pipes or fittings, or both.
- 3.2.8 *shield, n*—an external metallic protective device designed to protect the sealing gasket from external elements that could cause failure of the sealing assembly.

4. Materials and Manufacture

- 4.1 Physical properties of gaskets shall comply with Specification C 564 using the applicable durometer hardness requirement of the column of Table 2 of that document as specified by the manufacturer.
- 4.2 Clamp assembly screws or bolts shall not have screwdriver slots.
- 4.3 All stainless steel shall meet the physical requirements of Specification A 240.

5. Elastomeric Gasket Requirements

- 5.1 The elastomeric gasket shall consist of one piece polychloroprene construction conforming to the physical requirements of Specification C 564.

TABLE 2 Dimensions and Tolerances for Hubless Pipe and Fittings

Size, in. (mm)	Outside Diameter, in. (mm)
1½ (38)	1.90 ± 0.06 (48.26 ± 1.52)
2 (51)	2.35 ± 0.09 (59.69 ± 2.29)
3 (76)	3.35 ± 0.09 (85.09 ± 2.29)
4 (102)	4.38+0.09-0.05 (111.25+2.29/-1.27)
5 (127)	5.30+0.09-0.05 (134.63+2.29/-1.27)
6 (152)	6.30+0.09-0.05 (160.02+2.29/-1.27)
8 (203)	8.38+0.13-0.09 (212.85+3.30/-2.29)
10 (254)	10.56 ± 0.09 (268.22 ± 2.29)
12 (305)	12.50 ± 0.09 (317.5 ± 2.29)
15 (381)	15.83 ± 0.09 (402.08 ± 2.29)

5.1.1 The elastomeric gasket shall have an inside center stop that does not create an enlargement chamber or recess with a ledge, shoulder, or reduction of pipe area or offer an obstruction to flow.

5.1.2 The elastomeric gasket shall be free of defects that affect the use and serviceability.

6. Clamp Assembly Requirements

6.1 The clamp assembly shall be made of material conforming to the requirements as outlined in Sections 4 and 6.

6.1.1 All metallic parts shall be of 300 series stainless steel and shall conform to the requirements of Specification A 240. All metallic parts made from round stock shall be of 300 series stainless steel and shall conform to the requirements of Specification A 493 (excluding copper bearing alloys).

6.1.2 Clamp assemblies shall be tested to withstand no less than 125 % of the manufacturers stated installation torque without visible signs of failure. The clamp assembly shall be tested over a steel mandrel of the appropriate diameter and torqued as required.

7. Couplings Requirements and Test Methods

7.1 Assemble each coupling to be tested according to the manufacturer’s instructions between two sections of randomly selected hubless cast iron soil pipe meeting the requirements of CISPI 301 or Specification A 888 and conduct deflection and shear tests. In addition, unrestrained hydrostatic tests shall be performed as detailed in 7.2.

7.1.1 Deflection Test:

7.1.1.1 A test apparatus such as the one shown in Fig. 2 is suggested. Other testing apparatus that provide restraint to the assembly shall also be permitted. Close the outboard ends of the pipe with test plugs.

7.1.1.2 Fill the assembly with water, expel all air, and hydrostatically pressurize to 8.6 psi (59.3 kPa) for the duration of the test. One pipe shall be rigidly supported and while the assembly is under pressure, raise the opposite end of the other pipe 1 in. (25 mm) per lineal foot of pipe. Maintain the pressure for 15 min. Any leakage shall mean failure.

7.1.2 Shear Test:

7.1.2.1 Support two joined lengths of randomly selected hubless cast iron soil pipe on blocks, a minimum of 1½ in. (38.1 mm) high, at three locations. One length shall be a minimum of 24 in. (609.6 mm) in length, supported on blocks, one near the uncoupled end, and the other immediately adjacent to the couplings. Firmly restrain this length in position as shown in Fig. 3. The other coupled length shall be a minimum of 5 ft (1.52 m) in length and supported by a single block 6 in. (152.4 mm) from the end of the pipe.

7.1.2.2 Fill the assembly with water and expel all air. Apply a load of 50 lb per in. (22.7 kg) of nominal diameter at a point 6 in. (152.4 mm) from the edge of the coupling upon a 12 in. (304.8 mm) length of 3 by 3 in. (76.2 by 76.2 mm) angle iron or load distribution pad located on the top of the pipe immediately adjacent to the coupling of the pipe having one support only. Under this loading there shall be no visible leakage or displacement of more than 3⁄8 in. (9.53 mm) from true alignment adjacent to the coupling, when an internal pressure equivalent to a 20 ft (6.10 m) head of water 8.6 psi (59.3 kPa) is applied. Maintain the load and internal pressure for 15 min.

7.2 Unrestrained Hydrostatic Joint Test:

7.2.1 Assemble each coupling to be tested according to the manufacturer’s instruction between two sections of machined steel pipe and conduct the unrestrained hydrostatic joint test.

7.2.2 The assembly shall consist of a maximum outside diameter pipe connected to a minimum outside diameter pipe with diameters as referenced in Table 2 and lengths as shown in Fig. 4. Machine the plain ends of the pipe to be used for the thrust test to the correct diameters. Plain ends shall have 0.015 in. (0.38 mm) deep grooves machined circumferentially around them at 1⁄8 in. (3.18 mm) intervals down the pipe section for a distance equal to that covered by the elastomeric sleeve of the coupling being tested. The tool used to machine the grooves shall have a 60° included angle and cut into the pipe from a perpendicular position. The surface between the grooves shall be a lathe turned surface of 125 RMS.

7.2.3 The plain ends of the pipe for the thrust test shall be uncoated and cleaned with acetone and thoroughly dried before each assembly.

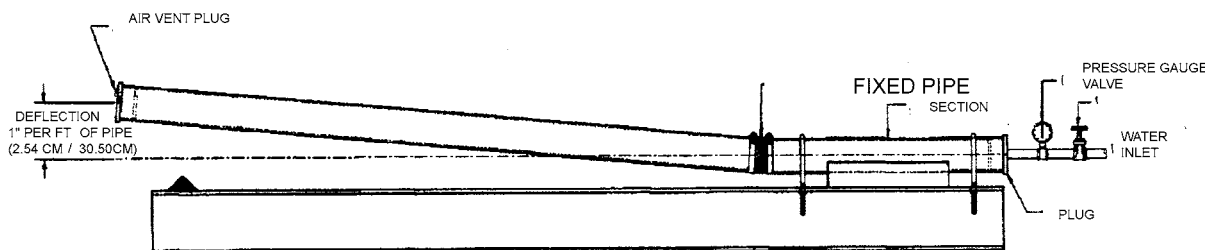

FIG. 2 Deflection Test

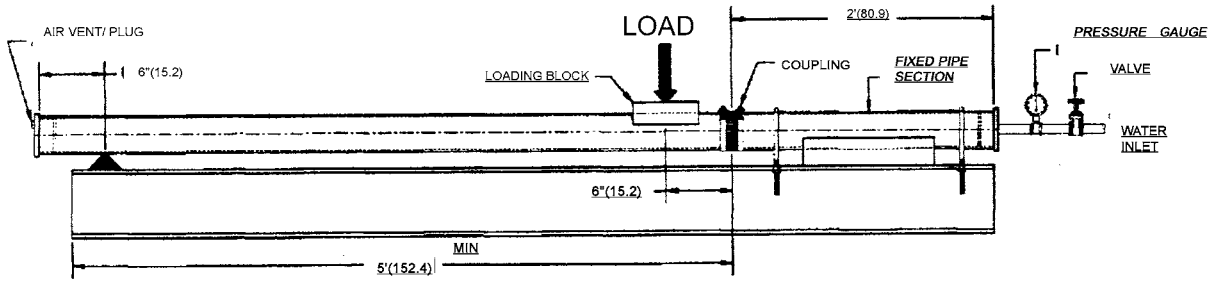

FIG. 3 Shear Test

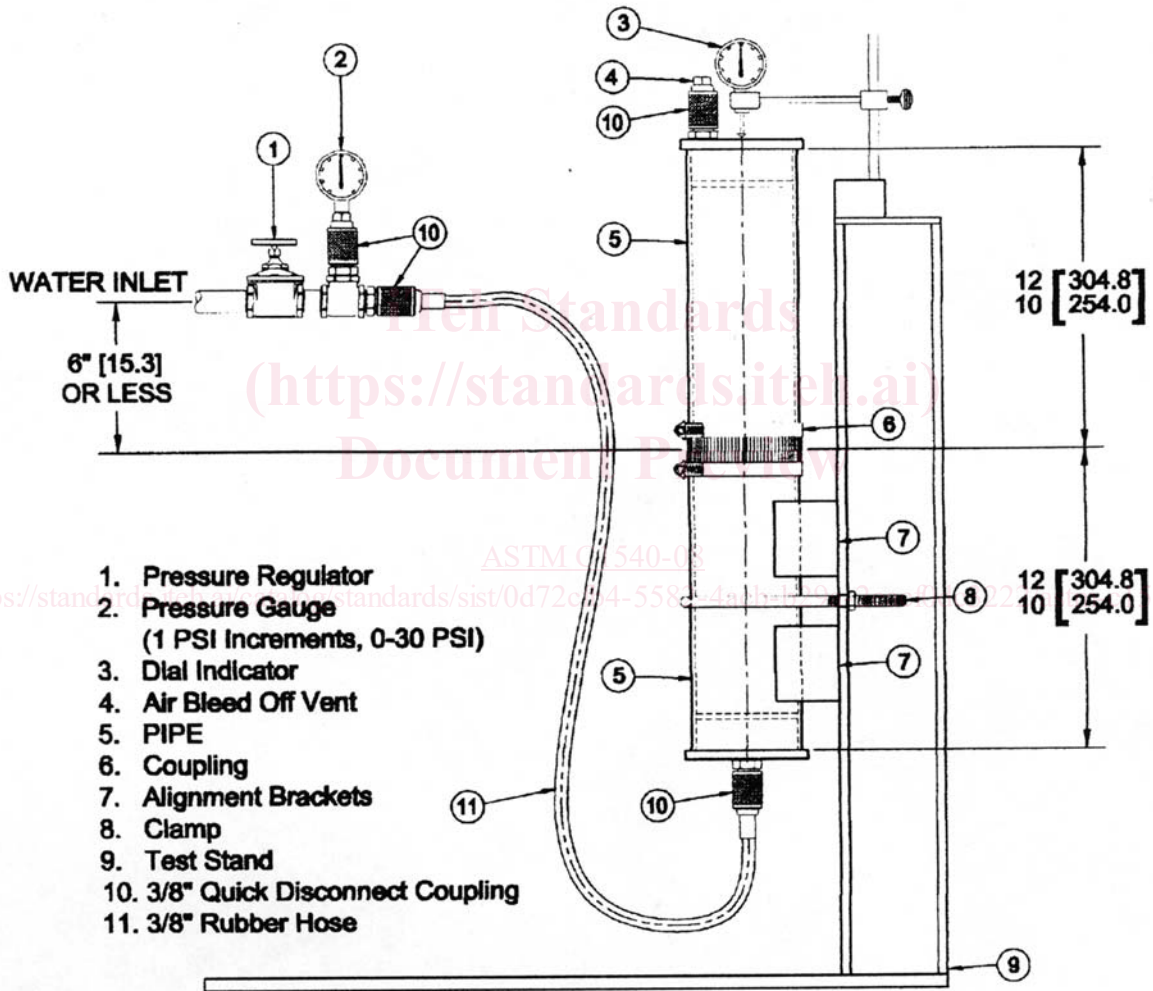

FIG. 4 Unrestrained Hydrostatic Joint Testing Apparatus

7.2.4 Test Method:

7.2.4.1 Support the pipe assemblies in a manner that does not restrain joint movement as shown in Fig. 4.

7.2.4.2 Fill the pipe assembly (as required in 7.2) with water, expelling all air. Increase the hydrostatic pressure at a rate of 1 psi (6.9 kPa) every 30 s until the specified test pressure is reached. The specified test pressure shall be 30 psi (206.8 kPa) for 1½ in. (38.1 mm) through 5 in. (127 mm), 27 psi (186 kPa) for 6 in. (152.4 mm), 15 psi (103.4 kPa) for 8 in. (203.2 mm), 9 psi (62 kPa) for 10 in. (254 mm), and 6 psi (31.3 kPa) for 12 and 15 in. pipe. When the specified test pressure is reached, hold it for 15 min. Any leakage or axial joint movement of more than 0.150 in. (3.81 mm) shall mean failure.

8. Markings and Identification

8.1 Permanently mark each clamp assembly with the manufacturer's name or U.S. registered trademark, country of origin, all stainless and the pipe size for which it is designed. Marking shall be visible after installation.

8.2 Gasket markings shall conform to Specification C 564.

8.3 The product shall also have any other markings required by law and shall have the option to include this designation (Specification C 1540).

APPENDIX

(Nonmandatory Information)

X1. INSTALLATION PROCEDURES FOR HUBLESS CAST IRON SOIL PIPE AND FITTINGS FOR SANITARY AND STORM DRAIN, WASTE AND VENT PIPING APPLICATIONS

X1.1 Introduction

X1.1.1 Several different types of hubless couplings are available for use in hubless cast iron sanitary and storm drain, waste, and vent piping applications to connect hubless cast iron soil pipe and fittings by using a sleeve-type, or some other type coupling device. It is the purpose of this portion of C 1540 to furnish procedures as to the installation of couplings, which are manufactured in accordance with C 1540 when applied to cast iron soil pipe and fittings manufactured in accordance with CISPI Standard 301 and Specification A 888, latest revisions. It must be noted that these installation procedures are not intended to be applicable for couplings not made in accordance with C 1540.

X1.1.2 The installation procedures stated below are illustrative only and are not a mandatory portion of C 1540.

X1.2 Purposes

X1.2.1 These installation procedures provide guidelines for installation, use and inspection of hubless cast iron soil pipe and fittings for sanitary and storm drain, waste, and vent piping applications when the coupling device described in C 1540 is used.

X1.2.2 All construction projects involve many variables, hence it is not possible to state in advance every installation consideration which may apply in the field. In the end the final and controlling judgment decisions concerning installation questions that arise must be made in the design and "on the job" taking into account prevailing circumstances or conditions. These procedures are not a substitute for such informed judgements and for manufacturer-provided installation instructions.

X1.2.3 Complete stability of all components of hubless cast iron soil pipe and fittings for sanitary and storm drain, waste, and vent piping applications should be given prime consideration.

X1.3 Methods of Cutting Cast Iron Soil Pipe

X1.3.1 There are several methods of successfully cutting cast iron soil pipe. These methods may be placed into two basic categories; those that require external power for their operation and those methods that require only hand operation. Methods that require external power are usually used for prefabrication work or high volume cutting operations. Examples of this type of equipment would be: (1) the abrasive saw (chop SAW), (2) power hack saw, and (3) an electrically actuated hydraulic snap cutter. Before using electrical equipment of this nature, the manufacturer's operating instructions should be carefully reviewed for safe use of the equipment.

X1.3.2 There are two hand operated cutting tools that are used in the industry today: (1) the standard steel pipe cutter using cutting wheels specifically designed to cut cast iron soil pipe, and (2) the snap cutter. The snap cutter accounts for the majority of all cuts made on cast iron soil pipe in the field. There are several types of snap cutter available, the following procedure has been found to produce consistently good cuts:

X1.3.2.1 After marking the pipe length to be cut, position the chain cutter squarely around the pipe to ensure a straight cut. The maximum number of wheels possible should be in contact with the pipe.

X1.3.2.2 Score the pipe by applying pressure on the handles to make the cutter wheels indent the pipe.

X1.3.2.3 Rotate the pipe a few degrees and then apply quick final pressure to complete the cut. If a piece of pipe is unusually tough, score the pipe several times before making your final cut. Scoring the pipe before the actual cut is the key to a clean straight cut.

X1.3.3 Cast iron soil pipe may also be cut with a hammer and a cold chisel. This method of cutting is very time consuming and should only be used if snap cutters are not available. Again, protective equipment, such as safety goggles, should be used. The procedure for cutting soil pipe with a hammer and chisel are as follows:

X1.3.3.1 Measure the length to be cut and mark the cut line completely around the circumference of the pipe.

X1.3.3.2 Place the mark to be cut on a 2 by 4 so the edge of the 2 by 4 is directly under the mark.

X1.3.3.3 By striking the chisel with the hammer, cut a groove following your mark all the way around the circumference of the pipe.

X1.3.3.4 Continue cutting as outlined in X1.3.3.3 until the pipe is cut. This procedure may take several revolutions of the pipe before it is cut.



FIG. X1.1 Snap Cutter

NOTE X1.1—Installers should be aware of safety considerations, including the need to use protective equipment, such as safety goggles, when cutting cast iron soil pipe.

X1.4 Definitions

- X1.4.1 *alternately*—a change from one to another repeatedly.
- X1.4.2 *coupling*—a mechanical device by which the ends of pipe or fittings are connected.
- X1.4.3 *hanger*—a device by which or to which something is hung or hangs.
- X1.4.4 *joint*—a place where two ends of pipe or fittings are connected.
- X1.4.5 *restrain*—to limit, restrict or keep under control.
- X1.4.6 *restraint*—a device that restricts movement.
- X1.4.7 *seismic*—shock, earthquake, to shake.
- X1.4.8 *support*—to hold up or to serve as a foundation or prop.
- X1.4.9 *torque*—a force that produces or tends to produce rotation or torsion: A turning or twisting force.

X1.5 Clamp and Gasket Installation

X1.5.1 Hubless cast iron soil pipe is joined by using the hubless coupling. Several different types of hubless couplings are available. The following will outline the installation procedures of hubless couplings that meet the requirements of C 1540. It must be noted that these installation procedures are not intended to be applicable for couplings other than those manufactured in accordance with C 1540. Installation procedures from the manufacturer shall be followed for best performance. These couplings are manufactured using a stainless steel shield and clamp assembly and an elastomeric sealing sleeve conforming to the requirements of Specification C 564. The following steps should be taken to ensure a proper joint.

X1.5.1.1 Place the gasket on the end of one pipe or fitting and the stainless steel clamp and shield assembly on the end of the other pipe or fitting.

X1.5.1.2 Firmly seat the pipe or fitting ends against the integrally molded center stop inside the elastomeric sealing sleeve.

X1.5.1.3 Slide the stainless steel shield and clamp assembly into position centered over the gasket and tighten the bands. The bands should always be tightened using a properly calibrated torque wrench set at 80 lbf-in. or the specific torque required by the manufacturer of couplings, which require a higher torque.

X1.5.1.4 For couplings that have four bands, the following sequence should be tightened to 80 lbf-in.

- (1) First tighten the inner bands alternately to 80 lbf-in.
- (2) Next, tighten the outer bands alternately to 80 lbf-in.

X1.5.1.5 For couplings that have six bands, the following sequence should be tightened to 80 lbf-in.

- (1) First tighten the innermost bands alternately to 80 lbf-in.
- (2) Next, move outward to the next set of bands and tighten alternately to 80 lbf-in.

X1.5.1.6 Once the coupling is installed and torqued in this pattern, it is not necessary to go back and re-torque the coupling.