**Resistance welding equipment —
Transformers — Integrated
transformer-rectifier units for welding
guns operating at 1 000 Hz**

*Équipement de soudage par résistance — Transformateurs
— Transformateurs-redresseurs pour pinces de soudage à
transformateur incorporé alimentés sous une fréquence de 1000 Hz*

iTeh STANDARD PREVIEW
(standards.iteh.ai)

[ISO 22829:2017](https://standards.iteh.ai/catalog/standards/sist/464fc21f-43d1-4d6b-be7f-9cde6739de9c/iso-22829-2017)

<https://standards.iteh.ai/catalog/standards/sist/464fc21f-43d1-4d6b-be7f-9cde6739de9c/iso-22829-2017>



iTeh STANDARD PREVIEW
(standards.iteh.ai)

[ISO 22829:2017](https://standards.iteh.ai/catalog/standards/sist/464fc21f-43d1-4d6b-be7f-9cde6739de9c/iso-22829-2017)

<https://standards.iteh.ai/catalog/standards/sist/464fc21f-43d1-4d6b-be7f-9cde6739de9c/iso-22829-2017>



COPYRIGHT PROTECTED DOCUMENT

© ISO 2017, Published in Switzerland

All rights reserved. Unless otherwise specified, no part of this publication may be reproduced or utilized otherwise in any form or by any means, electronic or mechanical, including photocopying, or posting on the internet or an intranet, without prior written permission. Permission can be requested from either ISO at the address below or ISO's member body in the country of the requester.

ISO copyright office
Ch. de Blandonnet 8 • CP 401
CH-1214 Vernier, Geneva, Switzerland
Tel. +41 22 749 01 11
Fax +41 22 749 09 47
copyright@iso.org
www.iso.org

Contents

	Page
Foreword	iv
1 Scope	1
2 Normative references	1
3 Terms and definitions	1
4 Power supply to the transformer-rectifier unit	1
5 Transformer types	2
6 Dimensions	2
7 Additional equipment	3
7.1 Grounding provision	3
7.2 Thermal protection	3
7.3 Output current sensing coil	3
7.4 Output voltage sensing wires	3
8 Protection of the rectifier	3
9 Marking	3
9.1 Primary	3
9.2 Output terminals	3
9.3 Rating plate	4
10 Designation	4
11 Test conditions	4
11.1 Type tests	4
11.2 Routine tests	5
11.3 Test procedures	5
11.3.1 General visual examination	5
11.3.2 Open-circuit tests	5
11.3.3 Minimum output current under load condition	5
11.3.4 Cooling circuit test	5
11.3.5 Dynamic behaviour of the output terminals	5
11.3.6 Mechanical strength	7
Annex A (informative) Relationship between output current and duty factor	8
Annex B (normative) Dimensions of transformers	9
Bibliography	15

Foreword

ISO (the International Organization for Standardization) is a worldwide federation of national standards bodies (ISO member bodies). The work of preparing International Standards is normally carried out through ISO technical committees. Each member body interested in a subject for which a technical committee has been established has the right to be represented on that committee. International organizations, governmental and non-governmental, in liaison with ISO, also take part in the work. ISO collaborates closely with the International Electrotechnical Commission (IEC) on all matters of electrotechnical standardization.

The procedures used to develop this document and those intended for its further maintenance are described in the ISO/IEC Directives, Part 1. In particular the different approval criteria needed for the different types of ISO documents should be noted. This document was drafted in accordance with the editorial rules of the ISO/IEC Directives, Part 2 (see www.iso.org/directives).

Attention is drawn to the possibility that some of the elements of this document may be the subject of patent rights. ISO shall not be held responsible for identifying any or all such patent rights. Details of any patent rights identified during the development of the document will be in the Introduction and/or on the ISO list of patent declarations received (see www.iso.org/patents).

Any trade name used in this document is information given for the convenience of users and does not constitute an endorsement.

For an explanation on the voluntary nature of standards, the meaning of ISO specific terms and expressions related to conformity assessment, as well as information about ISO's adherence to the World Trade Organization (WTO) principles in the Technical Barriers to Trade (TBT) see the following URL: www.iso.org/iso/foreword.html. (standards.iteh.ai)

This document was prepared by Technical Committee ISO/TC 44, *Welding and allied processes*, Subcommittee SC 6, *Resistance welding and allied mechanical joining*.

This second edition cancels and replaces the first edition (ISO 22829:2007), which has been technically revised.

Requests for official interpretations of any aspect of this document should be directed to the Secretariat of ISO/TC 44/SC 6 via your national standards body. A complete listing of these bodies can be found at www.iso.org.

Resistance welding equipment — Transformers — Integrated transformer-rectifier units for welding guns operating at 1 000 Hz

1 Scope

This document specifies additional requirements to those given in ISO 5826 for single-phase inverter transformers with connected rectifier for DC welding. This document applies to transformers, primarily used in welding guns, operating at 1 000 Hz with a rated input voltage of 500 V or more.

The requirements of ISO 5826 shall be followed unless amended by this document.

2 Normative references

The following documents are referred to in the text in such a way that some or all of their content constitutes requirements of this document. For dated references, only the edition cited applies. For undated references, the latest edition of the referenced document (including any amendments) applies.

ISO 669, *Resistance welding — Resistance welding equipment — Mechanical and electrical requirements*

ISO 5826, *Resistance welding equipment — Transformers — General specifications applicable to all transformers*

ISO 17677-1, *Resistance welding — Vocabulary — Part 1: Spot, projection and seam welding*

IEC 60417:2002, *Graphical symbols for use on equipment*

3 Terms and definitions

For the purposes of this document, the terms and definitions given in ISO 669, ISO 5826 and ISO 17677-1 and the following apply.

ISO and IEC maintain terminological databases for use in standardization at the following addresses:

- ISO Online browsing platform: available at <http://www.iso.org/obp>
- IEC Electropedia: available at <http://www.electropedia.org/>

3.1

output DC current

I_{2d}

root-mean-square (RMS) value of the direct current at the output terminals of the transformer-rectifier unit

3.2

on time

t_s

time during which the current is applied

4 Power supply to the transformer-rectifier unit

The rated voltage supply shall be delivered by an inverter. This inverter shall deliver the rated voltage at a frequency of 1 000 Hz in a waveform to suit the transformer-rectifier unit characteristics.

5 Transformer types

The minimum principal electrical characteristics of a transformer-rectifier unit shall conform to [Table 1](#).

Table 1 — Electrical characteristics

Type	Nominal value of the DC no load voltage U_{2d} V	Minimum rated permanent apparent input power S_{1p} kVA	Minimum permanent output current I_{2p} kA	Minimum output current on load condition I_{2R}^a kA
H1	6,3	36,0	5,0	11
H2	8,4	45,0	5,0	14
J1	6,3	45,0	6,3	18
J2	10,0	68,0	6,3	28
J3	9,3	63,0	6,3	25
J4	12,5	83,0	6,3	32
N1	10,4	64,0	5,7	20
P1	12,2	75,0	5,7	27
S1	8,2	71,0	6,3	25

^a $R = 200 \mu\Omega \pm 5\%$ = load resistance.

NOTE Indicated values are RMS values and are given for a cooling liquid flow rate of 6 l/min for types J1, J2, H, N and P, and of 8 l/min for types J3, J4 and S, with a maximum temperature of the cooling liquid at transformer input of 30 °C.

The manufacturer of transformer-rectifier units shall provide a set of curves showing the maximum output current relative to duty factor and welding time at the rated supply voltage. An example of a set of curves is given in [Annex A](#).

6 Dimensions

The dimensions of the transformer-rectifier unit shall be as given in [Table 2](#) and as illustrated in [Annex B](#).

Table 2 — Transformer-rectifier unit dimensions

Dimensions in millimetres

Type	Maximum length L_1	Length between mounting holes L_2	Overall width	Overall height	Output terminals dimensions
H1	270	170	106	150	32 × 32
H2	270	170	106	150	32 × 32
J1	300	190	125	160	32 × 32
J2	300	190	125	160	32 × 32
J3	300	190	125	160	40 × 50
J4	360	250	125	160	40 × 50
N1	400	115	130	190	45 × 50
P1	400	128	125	200	50 × 50
S1	370	279	127	171	51 × 67

7 Additional equipment

7.1 Grounding provision

The transformer shall be provided with a ground terminal that is connected to its case. The mid-point of the secondary winding shall be connected to the ground terminal by a removable link.

7.2 Thermal protection

The rectifier and the primary and secondary windings of the transformer shall be equipped with thermostiches. The position of the wiring shall be according to [Figure B.1](#) to [Figure B.6](#).

The wiring colour shall be as follows:

- thermostat on primary winding: light blue;
- thermostat on secondary winding: black;
- thermostat on rectifier: yellow.

NOTE Additional requirements are given in ISO 5826.

7.3 Output current sensing coil

If the transformer-rectifier unit is equipped with an output current sensing coil, it shall comply with ISO 5826.

7.4 Output voltage sensing wires

If the transformer-rectifier unit is equipped with output voltage sensing wires, red and dark blue colour coding shall be used for the wiring. The red wire shall be connected to the “+” output terminal and the dark blue wire to the “-” output terminal.

The wiring shall be protected from short-circuit currents by suitable means, e.g. by fuses, resistors or positive temperature coefficient thermistors.

If a resistor or a positive temperature coefficient thermistor is used, a value of 100 Ω is recommended.

8 Protection of the rectifier

The rectifier should be protected against the accumulation of welding spatter and other contamination.

9 Marking

9.1 Primary

Identification of the voltage and ground connections shall be clearly marked: U, V and the symbol \oplus in accordance with IEC 60417:2002.

The connection to the mid-point of the transformer shall be marked with “MP”.

9.2 Output terminals

The polarity of the output terminals shall be marked on the transformer and on the technical documentation with the symbols “+” and “-” in accordance with [Figure B.1](#) to [Figure B.6](#).

9.3 Rating plate

The rating plate shall conform with ISO 5826 except that box 4 shall reference this document and year of publication, i.e. ISO 22829:2017.

10 Designation

The designation shall comprise the following information in the order given:

- a) a reference to this document, i.e. ISO 22829:2017;
- b) type of transformer-rectifier unit (e.g. "H1");
- c) DC no load voltage, U_{2d} ;
- d) minimum permanent output current, I_{2p} (see [Table 1](#));
- e) rated supply voltage, U_{1N} , and frequency;
- f) T, indicating presence of thermostats;
- g) M, indicating presence of current sensing coil;
- h) U, indicating presence of voltage sensing wires.

EXAMPLE ISO 22829 — H1 — 6,3 — 5,4 — 500/1000 — TMU

iteh STANDARD PREVIEW
(standards.iteh.ai)

11 Test conditions

11.1 Type tests

ISO 22829:2017

<https://standards.iteh.ai/catalog/standards/sist/464fc21f-43d1-4d6b-be7f->

The following type tests shall be carried out, in the following order, in accordance with the procedures in ISO 5826, except where amended by this document:

- a) general visual examination (preliminary);
- b) insulation test (preliminary test);
- c) DC no load voltage, U_{2d} , open-circuit input current, I_{10} ;
- d) minimum output current under load condition;
- e) temperature-rise test;
- f) dynamic behaviour;
- g) calibration of the current sensing coil, if appropriate;
- h) insulation test;
- i) mechanical strength;
- j) dielectric test of the transformer-rectifier unit;
- k) cooling circuit;
- l) general visual examination (final).

The bandwidth of the reference measuring current and voltage systems shall be at least 100 kHz (–3 dB) and the accuracy class rating shall be 0,5 % of the upper limit of the full scale.

For temperature meters, the accuracy class rating shall be 0,5 % of the full scale.

11.2 Routine tests

The routine tests shall comprise only a reduced set of tests:

- general visual examination;
- dielectric tests;
- DC no load voltage, U_{2d} ;
- cooling circuit.

11.3 Test procedures

11.3.1 General visual examination

Visual examination shall be undertaken to assess visible imperfections. The visual examination performed at the end of the type test procedure shall include the measurement of the dimensions of the transformer-rectifier unit. The dimensions measured shall be reported.

11.3.2 Open-circuit tests

Testing shall be carried out in accordance with ISO 5826.

At the rated supply voltage, U_{1N} , the open-circuit input current, I_{10} , shall meet the following condition [see [Formula \(1\)](#)]:

$$I_{10} \leq \frac{0,04 \times S_{1p}}{U_{1N}} \quad (1)$$

11.3.3 Minimum output current under load condition

Test shall be performed according to ISO 5826 with a nominal load resistance value of 200 $\mu\Omega$.

The output current, I_{2R} , shall not be less than the values listed in [Table 1](#).

11.3.4 Cooling circuit test

The cooling liquid pressure drop shall not exceed 100 kPa (1 bar) for types J1, J2, H, N and P, and 160 kPa (1,6 bar) for types J3, J4 and S, when supplied at the nominal flow rate, Q .

NOTE 1 bar = 10^5 N/m² = 100 kPa.

The cooling liquid circuit shall be tight at a pressure of 1 000 kPa (10 bar) for 10 min for the type test. This test is not performed during the routine test.

Compliance is checked by leak-tightness and flow check.

11.3.5 Dynamic behaviour of the output terminals

The transformer-rectifier shall withstand the dynamic loads produced by a repetitive flow of welding or test current no less than three times the secondary permanent output current, I_{2p} , in the test configuration shown in [Figure 1](#).

The duty cycle shall be 1 % and the weld time shall be 60 ms.

The number of cycles shall be 2 500.

The dimension, a , shall be measured before and after the test has been performed. The deformation of the output terminals shall not cause the dimension, a , to change by more than 20 %.

Dimensions in millimetres

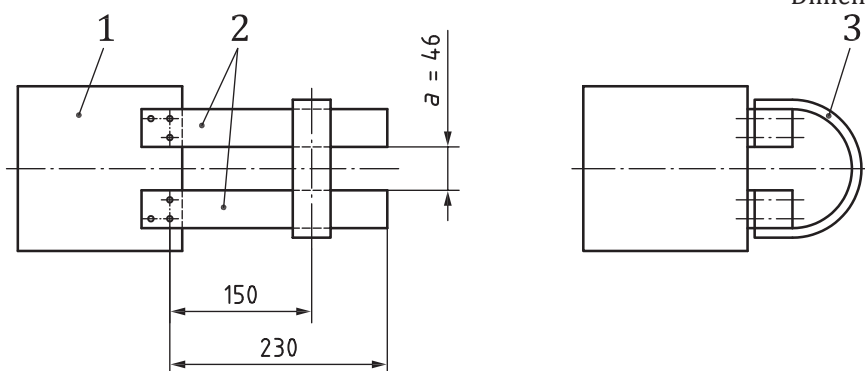

a) Types J1, J2 and H

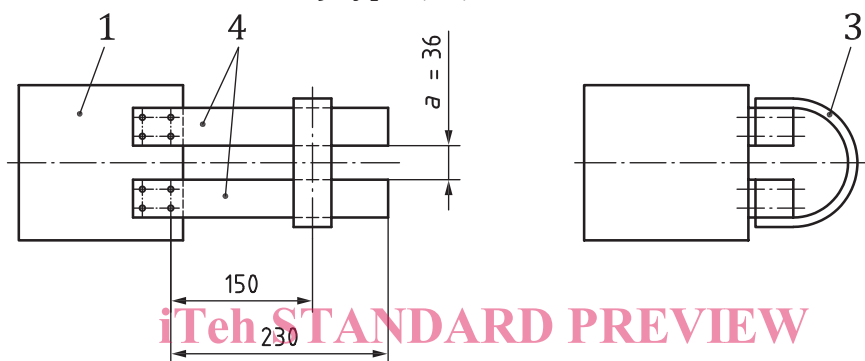

(standards.iteh.ai)

b) Types J3 and J4

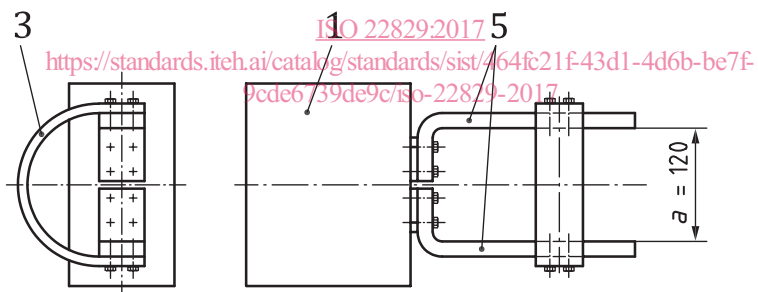

c) Types N and P

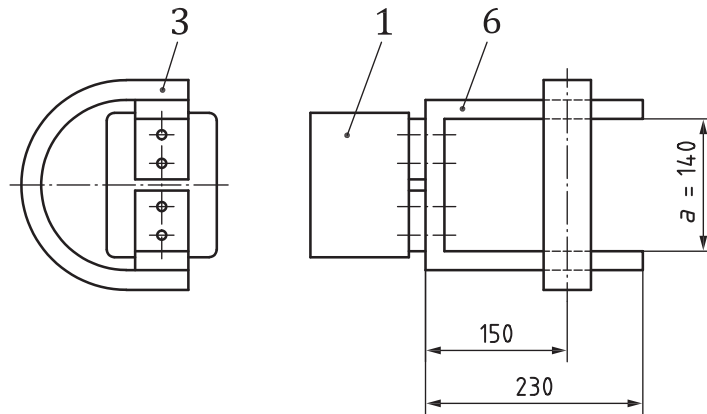

d) Type S

Key

- 1 transformer
- 2 copper bars 30 mm × 30 mm
- 3 flexible shunt
- 4 copper bars 40 mm × 40 mm
- 5 copper bars 20 mm × 50 mm
- 6 copper bars 25 mm × 60 mm

iTeh STANDARD PREVIEW
Figure 1 — Dynamic type test set up
 (standards.iteh.ai)

11.3.6 Mechanical strength

ISO 22829:2017

<https://standards.iteh.ai/catalog/standards/sist/464fc21f-43d1-4d6b-be7f-9dc6739de9c/iso-22829-2017>

The transformer shall be solidly secured on two plates, through the four M8 or M10 mounting holes of two opposite sides. A tensile load of 10 kN shall be progressively applied on both sides, such that the maximum loading is reached after 1 min and maintained for an additional 1 min. The test shall be repeated on the other two sides.

After testing, the transformer shall exhibit no permanent deformation or visible damage.