



# SLOVENSKI STANDARD SIST ETS 300 913 E6:2003

01-december-2003

---

8 [[ ]HJb]`W] b]`h`Y`\_ca i b]\_UW`g\_]`g]ghYa `fZuU&ŽL`E`Gd`cýbc`c`h`fa ]bUg\_]`  
df]U] UUb]`Z b\_W`U`nUa cV]bYdcgHUY`fA GL`f] GA`\$+`\$%žfU`h`] ]WU) ", "%L

Digital cellular telecommunications system (Phase 2+) (GSM); General on Terminal Adaptation Functions (TAF) for Mobile Stations (MS) (GSM 07.01 version 5.8.1)

**iTeh STANDARD PREVIEW**  
**(standards.iteh.ai)**

Ta slovenski standard je istoveten z: **ETS 300 913 Edition 6**  
<https://standards.iteh.ai/catalog/standards/sist/65717511-6c55-45b8-8b9c-ad77943ccade/sist-ets-300-913-e6-2003>

---

**ICS:**

33.070.50	Globalni sistem za mobilno telekomunikacijo (GSM)	Global System for Mobile Communication (GSM)
-----------	---	--

**SIST ETS 300 913 E6:2003**

**en**

**iTeh STANDARD PREVIEW**  
**(standards.iteh.ai)**

SIST ETS 300 913 E6:2003

<https://standards.iteh.ai/catalog/standards/sist/657175f1-bc53-43b8-8b9c-ad77943ccade/sist-ets-300-913-e6-2003>



**E**UROPEAN  
**T**ELECOMMUNICATION  
**S**TANDARD

**ETS 300 913**

October 1998

Sixth Edition

Source: SMG

Reference: RE/SMG-040701QR8

ICS: 33.020

**Key words:** Digital cellular telecommunications system, Global System for Mobile communications (GSM)



**Digital cellular telecommunications system (Phase 2+);  
General on Terminal Adaptation Functions (TAF)  
for Mobile Stations (MS)  
(GSM 07.01 version 5.8.1)**

**ETSI**

European Telecommunications Standards Institute

**ETSI Secretariat**

**Postal address:** F-06921 Sophia Antipolis CEDEX - FRANCE

**Office address:** 650 Route des Lucioles - Sophia Antipolis - Valbonne - FRANCE

**Internet:** secretariat@etsi.org - <http://www.etsi.org>

Tel.: +33 4 92 94 42 00 - Fax: +33 4 93 65 47 16

**Copyright Notification:** No part may be reproduced except as authorized by written permission. The copyright and the foregoing restriction extend to reproduction in all media.

© European Telecommunications Standards Institute 1998. All rights reserved.

## iTeh STANDARD PREVIEW (standards.iteh.ai)

[SIST ETS 300 913 E6:2003](https://standards.iteh.ai/catalog/standards/sist/657175f1-bc53-43b8-8b9c-ad77943ccade/sist-ets-300-913-e6-2003)

<https://standards.iteh.ai/catalog/standards/sist/657175f1-bc53-43b8-8b9c-ad77943ccade/sist-ets-300-913-e6-2003>

## Contents

Foreword .....	5
1 Scope .....	7
2 Normative references .....	7
3 Abbreviations .....	9
4 Access reference configuration .....	10
5 Functions to support data services .....	10
6 Support of non transparent Bearer Services .....	11
6.1 Functions of the Layer 2 Relay .....	11
6.2 Radio Link Services Used .....	12
6.3 Flow Control - General Description .....	12
6.3.1 End to End Flow Control .....	12
6.3.2 Back Pressure.....	12
6.3.3 Receive not Ready.....	13
7 Structure of the GSM 07-series of Specifications .....	13
8 Functions common to all interfaces .....	13
8.1 Synchronization of the Traffic Channel.....	13
8.2 Filtering of Channel Control Information.....	15
8.2.1 General.....	15
8.2.2 Filtering process to be applied.....	15
8.3 Terminal Compatibility Decision .....	16
8.3.1 Compatibility Check .....	17
8.3.2 Selection of Appropriate Terminal Function.....	17
8.3.3 Indication of Compatibility Requirements to the PLMN.....	17
8.3.3.1 Indication in case of Mobile terminating calls.....	17
8.3.3.2 Indication in case of Mobile originating calls .....	19
8.4 Test Loops.....	20
8.5 Alternate speech/data and speech/facsimile group 3.....	20
8.6 Multislot configuration spit/combine function.....	21
8.6.1 Non-transparent data .....	21
8.6.2 Transparent data.....	21
Annex A (Informative): List of Bearer Capability Elements .....	22
Annex B (Normative): Setting of Bearer Capability, Low Layer Compatibility and High Layer Compatibility Information Element for GSM Bearer Services and GSM TeleServices .....	29
B.0 Scope.....	29
B.1 Bearer Capability Information Element .....	29
B.1.1 Introduction.....	29
B.1.1.1 General Consideration .....	29
B.1.1.2 Interpretation of the Diagrams .....	30
B.1.2 Bearer Service 20 ... 26, Data Circuit Duplex Asynchronous .....	40
B.1.2.1 Unrestricted / restricted digital information transfer capability .....	40
B.1.2.2 3.1 kHz audio ex-PLMN information transfer capability .....	42
B.1.3 Bearer Service 30 ... 34, Data Circuit Duplex Synchronous.....	44
B.1.3.1 Unrestricted digital information transfer capability .....	44

	B.1.3.1.1	Non-X.32 Cases .....	44
	B.1.3.1.2	X.32 Case (Packet Service) .....	45
	B.1.3.1.4	48kbit/s and 56 kbit/s transparent Case .....	47
	B.1.3.1.5	64kbit/s bit transparent Case .....	48
	B.1.3.2	3.1 kHz audio ex-PLMN information transfer capability .....	49
	B.1.3.2.1	Non-X.32 Cases .....	49
	B.1.3.2.2	X.32 Case (Packet Service) .....	50
B.1.4		Bearer Service 40 ... 46, PAD Access Asynchronous .....	51
B.1.5		Bearer Service 50 ... 53 ,Data Packet Duplex Synchronous, Unrestricted digital information transfer capability .....	52
B.1.6		Bearer Service 61, Alternate Speech/Data .....	53
	B.1.6.1	Bearer Service 61,Speech .....	53
	B.1.6.2	Bearer Service 61, 3.1 kHz audio ex-PLMN information transfer capability..	54
	B.1.6.2.1	Asynchronous .....	54
	B.1.6.2.2	Synchronous.....	55
B.1.7		Bearer Service 81, Speech followed by Data .....	56
	B.1.7.1	Bearer Service 81,Speech .....	56
	B.1.7.2	Bearer Service 81, 3.1 kHz audio ex-PLMN information transfer capability..	56
	B.1.7.2.1	Asynchronous .....	56
	B.1.7.2.2	Synchronous.....	56
B.1.8		Teleservice 11 ... 12, Speech .....	56
B.1.9		Teleservice 21 ... 23, Short Message .....	56
B.1.10		Teleservice 61, Alternate Speech and Facsimile group 3 .....	56
	B.1.10.1	Teleservice 61, Speech.....	56
	B.1.10.2	Teleservice 61, Facsimile group 3 .....	57
B.1.11		Teleservice 62, Automatic Facsimile group 3.....	57
B.1.12		Valid combinations of FNUR, WAIUR, ACC, mTCH .....	58
	B.1.12.1	Transparent Services.....	58
	B.1.12.2	Non-transparent services.....	58
B.2		Low Layer/High Layer Compatibility Information Element .....	59
B.2.1		Introduction .....	59
	B.2.1.1	General Consideration.....	59
	B.2.1.2	Interpretation of the Tables .....	60
B.2.2		LLC Bearer Service 21 ... 26 .....	61
	B.2.2.1	Unrestricted / restricted digital information transfer capability.....	61
	B.2.2.2	3.1 kHz audio ex-PLMN information transfer capability .....	61
B.2.3		LLC Bearer Service 31 ... 34.....	62
	B.2.3.1	Unrestricted / restricted digital information transfer capability.....	62
	B.2.3.2	3.1kHz audio ex-PLMN information transfer capability .....	62
B.2.4		LLC Bearer Services 41 ... 46.....	63
B.2.5		LLC Bearer Services 51 ... 53.....	63
	B.2.5.1	Unrestricted digital information transfer capability.....	63
B.2.6		LLC Bearer Service 61.....	63
	B.2.6.1	3,1 kHz audio ex-PLMN information transfer capability, Asynchronous.....	63
	B.2.6.2	3,1 kHz audio ex-PLMN information transfer capability, Synchronous .....	63
B.2.7		LLC Bearer Service 81.....	63
	B.2.7.1	3,1 kHz audio ex-PLMN information transfer capability, Asynchronous.....	63
	B.2.7.2	3,1 kHz audio ex-PLMN information transfer capability, Synchronous .....	63
B.2.8		HLC Teleservices 11 ... 12 .....	64
B.2.9		HLC Teleservices 21 ... 23 .....	64
B.2.10		HLC Teleservice 61 .....	64
B.2.11		HLC Teleservice 62 .....	64
		Annex C (Informative): Change history .....	65
		History.....	66

## Foreword

This European Telecommunication Standard (ETS) has been produced by the Special Mobile Group (SMG) of the European Telecommunications Standards Institute (ETSI).

This ETS outlines the functions needed for terminal adaptation within the digital cellular telecommunications system (Phase 2+).

The contents of this ETS is subject to continuing work within SMG and may change following formal SMG approval. Should SMG modify the contents of this ETS, it will be resubmitted for OAP by ETSI with an identifying change of release date and an increase in version number as follows:

Version 5.x.y

where:

- y the third digit is incremented when editorial only changes have been incorporated in the specification;
- x the second digit is incremented for all other types of changes, i.e. technical enhancements, corrections, updates, etc.

<b>Transposition dates</b>	
Date of adoption of this ETS:	23 October 1998
Date of latest announcement of this ETS (doa):	31 January 1999
Date of latest publication of new National Standard or endorsement of this ETS (dop/e):	31 July 1999
Date of withdrawal of any conflicting National Standard (dow):	31 July 1999

[SIST ETS 300 913 E6:2003](https://standards.iteh.ai/catalog/standards/sist/657175f1-bc53-43b8-8b9c-ad77943ccade/sist-ets-300-913-e6-2003)

<https://standards.iteh.ai/catalog/standards/sist/657175f1-bc53-43b8-8b9c-ad77943ccade/sist-ets-300-913-e6-2003>

Blank page

**iTeh STANDARD PREVIEW**  
**(standards.iteh.ai)**

[SIST ETS 300 913 E6:2003](https://standards.iteh.ai/catalog/standards/sist/657175f1-bc53-43b8-8b9c-ad77943ccade/sist-ets-300-913-e6-2003)

<https://standards.iteh.ai/catalog/standards/sist/657175f1-bc53-43b8-8b9c-ad77943ccade/sist-ets-300-913-e6-2003>



## 1 Scope

This European Telecommunications Standard (ETS) is based on the principles of terminal adaptor functions presented in the CCITT I-series of recommendations (I.460 - I.463).

The GSM PLMN supports a wide range of voice and non-voice services in the same network. In order to enable non-voice traffic in the GSM PLMN there is a need to connect various kinds of terminal equipments to the Mobile Termination (MT). The target of this ETS is to outline the functions needed for the terminal adaptation.

In the GSM 02.02 (ETS 300 904) the bearer services are described. The general network configuration is described in GSM 03.02 and the GSM PLMN access reference configuration is defined in GSM 04.02. The various connection types used in the GSM PLMN are presented in GSM 03.10. Terminology used in this ETS is presented in GSM 01.04 (ETR 350). For support of data services between GSM PLMN and other networks see GSM 09-series of Specifications.

## 2 Normative references

This ETS incorporates by dated and undated reference, provisions from other publications. These normative references are cited at the appropriate places in the text and the publications are listed hereafter. For dated references, subsequent amendments to or revisions of any of these publications apply to this ETS only when incorporated in it by amendment or revision. For undated references, the latest edition of the publication referred to applies.

- [1] GSM 01.04 (ETR 350): "Digital cellular telecommunication system (Phase 2); Abbreviations and acronyms".
- [2] GSM 02.02 (ETS 300 904): "Digital cellular telecommunication system (Phase 2+); Bearer Services (BS) supported by a GSM Public Land Mobile Network (PLMN)".
- [3] GSM 02.03 (ETS 300 905): "Digital cellular telecommunication system (Phase 2+); Teleservices supported by a GSM Public Land Mobile Network (PLMN)".
- [4] GSM 03.02: "Digital cellular telecommunication system (Phase 2+); Network architecture".
- [5] GSM 03.10: "Digital cellular telecommunication system (Phase 2+); GSM Public Land Mobile Network (PLMN) connection types".
- [6] GSM 04.02: "Digital cellular telecommunication system (Phase 2+); GSM Public Land Mobile Network (PLMN) access reference configuration".
- [7] GSM 04.08 (ETS 300 940): "Digital cellular telecommunication system (Phase 2+); Mobile radio interface layer 3 specification".
- [8] GSM 04.21 (ETS 300 945): "Digital cellular telecommunication system; Rate adaption on the Mobile Station - Base Station System (MS - BSS) interface".
- [9] GSM 04.22 (ETS 300 946): "Digital cellular telecommunication system (Phase 2+); Radio Link Protocol (RLP) for data and telematic services on the Mobile Station - Base Station System (MS - BSS) interface and the Base Station System - Mobile-services Switching Centre (BSS - MSC) interface".
- [10] GSM 05.05 (ETS 300 910): "Digital cellular telecommunication system (Phase 2+); Radio transmission and reception".
- [11] GSM 07.02 (ETS 300 914): "Digital cellular telecommunication system (Phase 2+); Terminal Adaptation Functions (TAF) for services using asynchronous bearer capabilities".

- [12] GSM 07.03 (ETS 300 915): "Digital cellular telecommunication system (Phase 2+); Terminal Adaptation Functions (TAF) for services using synchronous bearer capabilities".
- [13] GSM 07.05: "Digital cellular telecommunication system (Phase 2+); Use of Data Terminal Equipment - Data Circuit terminating Equipment (DTE - DCE) interface for Short Message Service (SMS) and Cell Broadcast Service (CBS)".
- [14] GSM 07.07 (ETS 300 916): "Digital cellular telecommunication system (Phase 2+); AT command set for GSM Mobile Equipment (ME)
- [15] GSM 09.01 (ETR 359): "Digital cellular telecommunication system (Phase 2); General network interworking scenarios".
- [16] GSM 09.02 (ETS 300 974): "Digital cellular telecommunication system (Phase 2+); Mobile Application Part (MAP) specification".
- [17] GSM 09.03: "Digital cellular telecommunication system; Signalling requirements on interworking between the Integrated Services Digital Network (ISDN) or Public Switched Telephone Network (PSTN) and the Public Land Mobile Network (PLMN)".
- [18] GSM 09.04: "Digital cellular telecommunication system; Interworking between the Public Land Mobile Network (PLMN) and the Circuit Switched Public Data Network (CSPDN)".
- [19] GSM 09.05: "Digital cellular telecommunication system; Interworking between the Public Land Mobile Network (PLMN) and the Packet Switched Public Data Network (PSPDN) for Packet Assembly/Disassembly (PAD) facility access".
- [20] GSM 09.06 (ETS 300 975): "Digital cellular telecommunication system (Phase 2+); Interworking between a Public Land Mobile Network (PLMN) and a Packet Switched Public Data Network/Integrated Services Digital Network (PSPDN/ISDN) for the support of packet switched data transmission services".
- [21] GSM 09.07 (ETS 300 976): "Digital cellular telecommunication system (Phase 2+); General requirements on interworking between the Public Land Mobile Network (PLMN) and the Integrated Services Digital Network (ISDN) or Public Switched Telephone Network (PSTN)".
- [22] GSM 09.08: "Digital cellular telecommunication system; Application of the Base Station System management Application Part (BSSMAP) on the E-interface".
- [23] GSM 09.10: "Digital cellular telecommunication system (Phase 2+); Information element mapping between Mobile Station - Base Station System and BSS - Mobile-services Switching Centre (MS - BSS - MSC) Signalling procedures and the Mobile Application Part (MAP)".
- [24] GSM 09.11: "Digital cellular telecommunication system (Phase 2+); Signalling interworking for supplementary services".
- [25] GSM 09.90: "Digital cellular telecommunication system (Phase 2+); Interworking between Phase 1 infrastructure and Phase 2+ Mobile Stations (MS)".
- [26] CCITT Series V Recommendations: "Data communication over the Telephone network".
- [27] CCITT Series V.42bis: "Data Compression for Data Circuit Terminating Equipment (DCE) using Error Correction Procedures".
- [28] CCITT Series X Recommendations: "Data Communication networks".

- [29] CCITT Recommendation X.25 "Interface between data terminal equipment (DTE) and data circuit - terminating equipment (DCE) for terminals operating in the packet mode and connected to public data networks by dedicated circuit".
- [30] CCITT Recommendation X.150: "Data Communication Networks: Transmission, Signalling and Switching, Network Aspects, Maintenance and Administrative Arrangements".
- [31] CCITT Recommendation V.25bis: "Automatic Calling and/or Answering Equipment on the General Switched Telephone Network (GSTN) using the 100-Series Interchange Circuits".
- [32] ITU-T Recommendation V.25ter: "Serial asynchronous automatic dialing and control".
- [33] CCITT Recommendation V.54: "Loop Test Devices for Modems".
- [34] CCITT Recommendation V.110: "Support of data terminal equipments (DTEs) with V-Series interfaces by an integrated services digital network".
- [35] CCITT Recommendation I.460-I.464: "ISDN Overall Network Aspects and Functions, User Network Interfaces".
- [36] ETS 300 102-1: "Integrated Services Digital Network (ISDN); User-network interface layer 3 specifications for basic call control".
- [37] ETR 018: "Integrated Services Digital Network (ISDN), Application of the BC-, HLC-, LLC-Information elements by terminals supporting ISDN services".
- [38] ISO/IEC 6429: "Information technology - Control functions for coded character sets".
- [39] Personal Computer Memory Card Association: "PCMCIA 2.1 or PC-Card 3.0 electrical specification or later revisions".
- [40] IrDA "IrPHY Physical signalling standard".
- [41] TIA-617: "Data Transmission Systems and Equipment - In-Band DCE Control".
- [42] CCITT Recommendation V.120: "Support by an ISDN of data terminal equipment with V-Series type interfaces with provision for statistical multiplexing".
- [43] GSM 03.34 (TS 101 038): "Digital cellular telecommunication system (Phase 2+); High Speed Circuit Switched Data (HSCSD); Stage 2 Service description".

### 3 Abbreviations

In addition to those below, abbreviations used in this ETS are listed in GSM 01.04.

CALL PROC	CALL PROCEEDING
CALL CONF	CALL CONFIRMED
CONNACK	CONNECT ACKNOWLEDGEMENT

## 4 Access reference configuration

Figure 1 presents the reference configuration for access to a GSM PLMN (see GSM 04.02).

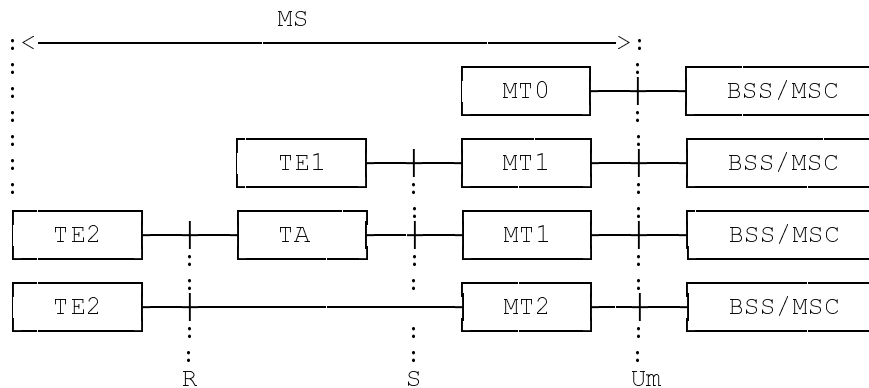

⊕ = reference point

TE1 = ISDN terminal

TE2 = V- or X-type terminal

TA = Terminal Adaptor

BSS = Base Station System

MSC = Mobile Switching Centre

**Figure 1: GSM PLMN Access Reference Configuration**

Within the scope of this ETS the Mobile Termination MT0 means a fully integrated MS including data terminal and its adaptation functions. MT1 includes ISDN terminal adaptation functions and MT2 includes CCITT V- or X-series terminal adaptation functions among other MT functions.

## 5 Functions to support data services

<https://standards.iteh.ai/catalog/standards/sist/657175f1-bc53-43b8-8b9c-d5792e2e1e1c/ets-300-913-e6-2003>

The main functions of the MT to support data services are:

- functions to ensure conformity of terminal service requests to network capability;
- physical connection of the reference points R and S;
- flow control of signalling and mapping of user signalling to/from GSM PLMN access signalling;
- rate adaptation of user data (see GSM 04.21);
- flow control of non-transparent user data and mapping of flow control for asynchronous data services;
- support of data integrity between the MS and the interworking function in the GSM PLMN;
- end-to-end synchronization between terminals;
- filtering of status information;
- functions to support non-transparent bearer services e.g. termination of the Radio Link Protocol (RLP) and the Layer 2 Relay function (L2R) including optional data compression function (where applicable);
- terminal compatibility checking;
- optional support of local test loops.

In addition, functions to support autocalling and autoanswering are optionally specified in accordance with CCITT Rec. V.25 bis or with ITU-T Rec. V.25 ter (although the use of other autocalling/auto-answering

procedures are not prohibited provided that mapping in a functionally equivalent way to GSM 04.08 call control is also provided).

Other functional entities can be envisaged apart from the TAF. One of the physical interface to all these functions is the DTE/DCE interface to the MT. Normally, this DTE/DCE interface is associated with the TAF, if available. Therefore the access to any of these other functional entities, if implemented, via the DCE/DTE interface must be triggered by appropriate command sequences which are described in the applicable specifications (although the use of other procedures is not prohibited provided that mapping in a functionally equivalent way is also provided). These command sequences can be issued by the DTE only when the MT is in the appropriate command status and there is no data connection pending. They are interpreted by an MT internal control function and result in an association of the DTE/DCE interface with the addressed function, if available.

## 6 Support of non transparent Bearer Services

In order to support non transparent bearer services a Layer 2 Relay (L2R) function is included in the mobile termination. The details of the particular L2R function for the different non transparent bearer services are contained in the appropriate GSM 07-series Specification. This section describes the general aspects of the L2R function.

The Layer 2 Relay (L2R) function provides for the reliable transportation of known, i.e. non transparent, user protocols across the radio interface of a GSM PLMN. The L2R functions are located in the Mobile Termination (MT) and the Interworking Function (IWF) associated with a Mobile Switching Centre (MSC). The L2R uses the services provided by the Radio Link Protocol (RLP) to transport the non transparent protocol information between the MS and the IWF.

### 6.1 Functions of the Layer 2 Relay

The complete protocol reference models for data and telematic services are described in GSM 03.10. The subset of those protocol reference models relating to the L2R function is reproduced in figure 2.

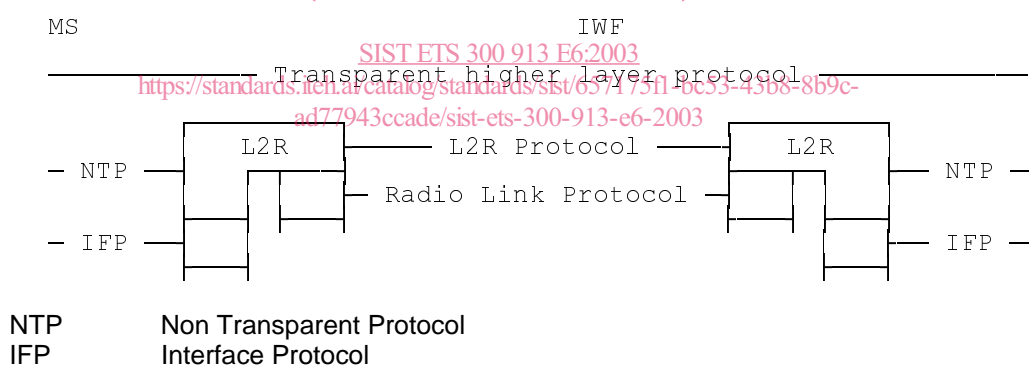

Figure 2

The Non Transparent Protocol (NTP) will normally be a layer 2 protocol for OSI conformant protocols or an equivalent in the case of non OSI protocols. The Interface Protocol (IFP) will normally be a layer 1 protocol for OSI conformant systems or equivalent for non OSI systems.

The L2R can be considered to consist of 3 sub-functions, see figure 3.

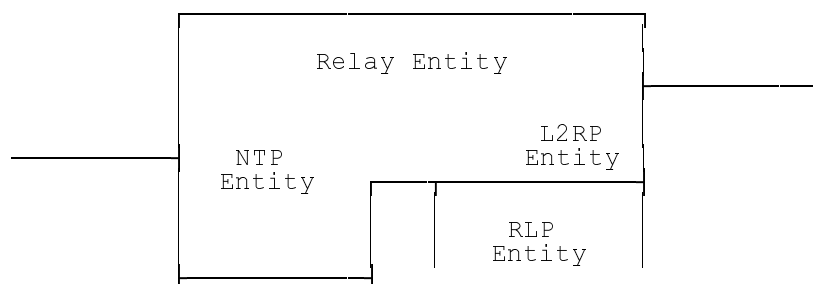

Figure 3

The 3 sub-functions are:

- A Non Transparent Protocol Entity
- A L2R Protocol Entity
- A Relay Entity

The NTP-entity interfaces the L2R to the IFP-entity and provides an interface to the particular NTP.

The L2RP-entity interfaces the L2R to the RLP-entity and provides an interface to the appropriate L2R protocol.

The Relay-entity provides the mapping between the NTP-entity and the L2R-entity. If applicable, it contains the data compression function. The negotiable parameters are exchanged with the remote Relay-entity by means of the RLP XID frame.

It should be noted that the inter-layer interfaces within the MS and the IWF and within the L2R will not be specified by GSM, any description given is for explanatory purposes only and is not intended to indicate a method of implementation. Therefore, the specification of the L2R is in terms of the peer-peer protocols. Generally, the non transparent and interface protocols will be specified elsewhere, e.g. CCITT Recommendation X.25 Layer 2 and 1. Thus the main specification for the L2R will consist of the L2R peer-peer protocols.

## 6.2 Radio Link Services Used

The L2R function uses services defined in GSM Specification 04.22 (Radio Link Protocol).

## 6.3 Flow Control - General Description

A flow control active condition can take place under a number of circumstances:

- End to end flow control (DTE to DTE matter);
- Backpressure (buffers filling);
- Receive not ready (RLP condition).

It is possible that there will be an interaction between flow control active and inactive conditions in each circumstance.

### 6.3.1 End to End Flow Control

A DTE may wish to send a flow control active condition to another DTE.

Provisions exists in the L2R entity to transfer a flow control active condition (sent by its associated DTE) to the other L2R entity as soon as possible. This mechanism in the L2R entities allows such a flow control condition to be put ahead of any queuing which exists in the L2R entities.

Such a mechanism avoids build up of data in buffers which can be undesirable.

The L2R entity, receiving a flow control active condition from its associated DTE, stops sending data to that associated DTE immediately.

### 6.3.2 Back Pressure

The L2R and RLP entities have buffers which may become full to a predetermined threshold for a number of reasons, e.g. severe radio fading, failure or slowness of DTE to react to end to end flow control, certain RNR conditions. When this predetermined threshold is reached, a flow control active condition is sent to the associated DTE which is then prevented from sending any data, subsequently, the flow control inactive condition is sent to the associated DTE when the L2R or RLP entities have indicated that there is sufficient free capacity in their buffers for data flow from the associated DTE to proceed.

The corresponding peer-layer procedure to assess the respective buffer conditions are a layer management matter and are not dealt with here. It is also considered an implementation matter to ensure that such procedure do not result in loss of data or considerable reduction in throughput.

### 6.3.3 Receive not Ready

When the RNR condition arises, an RLP indication is sent to the other RLP entity which in turn shall send a flow control active condition to its associated L2R entity. That L2R entity shall then send a flow control active condition to its associated DTE.

An RNR condition may result in the Execution of "back pressure" as mentioned under 6.3.2.

## 7 Structure of the GSM 07-series of Specifications

The structure of the Specifications is as follows:

- |       |   |
|-------|---|
| 07.01 | General on Terminal Adaptation Functions for Mobile Stations  |
| 07.02 | Terminal Adaptation Functions for Services using Asynchronous Bearer Capabilities   |
|       | This Specification defines the interfaces and terminal adaptation functions integral to a MT which enable the attachment of Asynchronous Terminals to a MT. |
| 07.03 | Terminal Adaptation Functions for Services using Synchronous Bearer Capabilities  |
|       | This Specification defines the interfaces and terminal adaptation functions integral to a MT which enable the attachment of Synchronous Terminals to a MT.  |

## 8 Functions common to all interfaces

### 8.1 Synchronization of the Traffic Channel

As long as there is no connection between the traffic channel and the interface to the TE this interface must be terminated in the appropriate way.

Prior to exposing the traffic channel of a GSM PLMN connection to transmission of user data, the controlling entities of the connection have to assure of the availability of the traffic channel(s). This is done by the so called synchronization process:

- starting on the indication of "physical connection established" resulting from the PLMN inherent outband signalling procedure. This indication is given on reception of the message CONNECT in case of MOC, on reception of the message CONNACK in case of MTC and on reception of the message MODIFY COMPLETE in case of in-call modification.
- ending by indicating the successful execution of this process to the controlling entity, which then takes care of the further use of the inband information (data, status).

With respect to the TAF for the transparent bearer capability support the synchronization procedure with the channel codings 2.4, 4.8 and 9.6 kbit/s is as follows:

- sending of synchronization pattern 1/OFF (all data bits "1" / all status bits "OFF", all E-bits "1") to the IWF. In multislot transparent operation, the synchronisation pattern sent is 1/OFF with the exception of the bit positions S1, first X, S3, and S4 which contain the substream number and multiframe alignment pattern (Ref. GSM TS 04.21);
- searching for detection of the synchronization pattern received from the IWF, and in multislot operation, also searching for the multiframe alignment pattern "0000 1001 0110 0111 1100 0110 1110 101" (Ref. to GSM 04.21) in bit position S4 and substream numbers in bit positions S1, first X, and S3. The value of the bits E4-E7 shall not be checked;
- holding CT106, 107 and 109 in the OFF condition;

With respect to the TAF for the transparent bearer capability support the procedure with the TCH/F14.4 is as follows: