



SLOVENSKI STANDARD
oSIST prEN 14972-17:2022
01-julij-2022

Vgrajeni gasilni sistemi - Sistemi s pršečo vodo - 17. del: Protokol preskušanja sistemov s samodejnimi šobami za stanovanjske prostore

Fixed firefighting systems - Water mist systems - Part 17: Test protocol for residential occupancies for automatic nozzle systems

Ortsfeste Brandbekämpfungsanlagen - Wassernebelsysteme - Teil 17: Prüfprotokoll für Wohnbelegungen für automatische Düsensysteme

Installations fixes de lutte contre l'incendie - Systèmes à brouillard d'eau - Partie 17 : Protocole d'essai des systèmes à buses automatiques pour locaux résidentiels

Ta slovenski standard je istoveten z: prEN 14972-17

ICS:

13.220.10 Gašenje požara Fire-fighting

oSIST prEN 14972-17:2022 **en,fr,de**

EUROPEAN STANDARD
NORME EUROPÉENNE
EUROPÄISCHE NORM

DRAFT
prEN 14972-17

April 2022

ICS 13.220.20; 13.220.99

English Version

Fixed firefighting systems - Water mist systems - Part 17: Test protocol for residential occupancies for automatic nozzle systems

Installations fixes de lutte contre l'incendie - Systèmes
à brouillard d'eau - Partie 17 : Protocole d'essai des
systèmes à buses automatiques pour locaux
résidentiels

Ortsfeste Brandbekämpfungsanlagen -
Wassernebelsysteme - Teil 17: Prüfprotokoll für
Wohnbelegungen für automatische Düsensysteme

This draft European Standard is submitted to CEN members for enquiry. It has been drawn up by the Technical Committee CEN/TC 191.

If this draft becomes a European Standard, CEN members are bound to comply with the CEN/CENELEC Internal Regulations which stipulate the conditions for giving this European Standard the status of a national standard without any alteration.

This draft European Standard was established by CEN in three official versions (English, French, German). A version in any other language made by translation under the responsibility of a CEN member into its own language and notified to the CEN-CENELEC Management Centre has the same status as the official versions.

CEN members are the national standards bodies of Austria, Belgium, Bulgaria, Croatia, Cyprus, Czech Republic, Denmark, Estonia, Finland, France, Germany, Greece, Hungary, Iceland, Ireland, Italy, Latvia, Lithuania, Luxembourg, Malta, Netherlands, Norway, Poland, Portugal, Republic of North Macedonia, Romania, Serbia, Slovakia, Slovenia, Spain, Sweden, Switzerland, Turkey and United Kingdom.

Recipients of this draft are invited to submit, with their comments, notification of any relevant patent rights of which they are aware and to provide supporting documentation.

Warning : This document is not a European Standard. It is distributed for review and comments. It is subject to change without notice and shall not be referred to as a European Standard.



EUROPEAN COMMITTEE FOR STANDARDIZATION
COMITÉ EUROPÉEN DE NORMALISATION
EUROPÄISCHES KOMITEE FÜR NORMUNG

CEN-CENELEC Management Centre: Rue de la Science 23, B-1040 Brussels

Contents		Page
European foreword		3
1	Scope.....	4
2	Normative references.....	4
3	Terms and definitions.....	4
4	General requirements.....	4
4.1	General.....	4
4.2	Fire test categories.....	4
5	Fuel packages	5
5.1	Ignition package.....	5
5.2	Fuel package	6
5.3	Plywood panels.....	6
6	Test arrangements	8
7	Fire tests.....	18
7.1	Description of fire tests for ceiling mounted nozzles	18
7.2	Description of fire tests for sidewall mounted nozzles.....	18
8	Testing criteria	19
9	Test report.....	19

[oSIST prEN 14972-17:2022](https://standards.iteh.ai/catalog/standards/sist/61f8b420-1a06-4d9c-b6a4-20611ce0fbff/osist-pren-14972-17-2022)

<https://standards.iteh.ai/catalog/standards/sist/61f8b420-1a06-4d9c-b6a4-20611ce0fbff/osist-pren-14972-17-2022>

European foreword

This document (prEN 14972-17:2022) has been prepared by Technical Committee CEN/TC 191 “Fixed firefighting systems”, the secretariat of which is held by BSI.

This document is currently submitted to the CEN Enquiry.

EN 14972, *Fixed firefighting systems — Water mist systems*, consists of the following parts:

- *Part 1: Design, installation, inspection and maintenance;*
- *Part 2: Test protocol for shopping areas for automatic nozzle systems;*
- *Part 3: Test protocol for office, school class rooms and hotel for automatic nozzle systems;*
- *Part 4: Test protocol for non-storage occupancies for automatic nozzle systems;*
- *Part 5: Test protocol for car garages for automatic nozzle systems;*
- *Part 6: Test protocol for false floors and false ceilings for automatic nozzle systems;*
- *Part 7: Test protocol for commercial low hazard occupancies for automatic nozzle systems;*
- *Part 8: Test protocol for machinery in enclosures exceeding 260 m³ for open nozzle systems;*
- *Part 9: Test protocol for machinery in enclosures not exceeding 260 m³ for open nozzle systems;*
- *Part 10: Test protocol for atrium protection with sidewall nozzles for open nozzle systems;*
- *Part 11: Test protocol for cable tunnels for open nozzle systems;*
- *Part 12: Test protocol for commercial deep fat cooking fryers for open nozzle systems;*
- *Part 13: Test protocol for wet benches and other similar processing equipment for open nozzle systems;*
- *Part 14: Test protocol for combustion turbines in enclosures exceeding 260 m³ for open nozzle systems;*
- *Part 15: Test protocol for combustion turbines in enclosures not exceeding 260 m³ for open nozzle systems;*
- *Part 16: Test protocol for industrial oil cookers for open nozzle systems;*
- *Part 17: Test protocol for residential occupancies for automatic nozzle systems.*

NOTE This list includes standards that are in preparation and other standards might be added. For current status of published standards refer to www.cencenelec.eu.

prEN 14972-17:2022 (E)**1 Scope**

This document specifies fire testing requirements for water mist systems used for fire protection of domestic and residential occupancies up to a maximum ceiling height of 5,5 m.

EXAMPLE Examples for residential occupancies are family dwelling/house, bed and breakfast, apartment buildings, blocks of flats, care homes, small hotels or hostels, and residential areas in hotel bedrooms and guest corridors.

NOTE Some countries might have a national annex with guidance on the maximum height of the building, minimum design area and any additional requirements.

2 Normative references

The following documents are referred to in the text in such a way that some or all of their content constitutes requirements of this document. For dated references, only the edition cited applies. For undated references, the latest edition of the referenced document (including any amendments) applies.

EN 520:2009, *Gypsum plasterboards — Definitions, requirements and test methods*

EN 13238, *Reaction to fire tests for building products — Conditioning procedures and general rules for selection of substrates*

EN 14972-1:2020, *Fixed firefighting systems — Water mist systems — Part 1: Design, installation, inspection and maintenance*

3 Terms and definitions

For the purposes of this document, the terms and definitions given in EN 14972-1 apply.

ISO and IEC maintain terminological databases for use in standardization at the following addresses:

- IEC Electropedia: available at <https://www.electropedia.org/>
- ISO Online browsing platform: available at <https://www.iso.org/obp>

4 General requirements**4.1 General**

Up to a maximum of 5 nozzles used in the fire tests shall be kept for later verification.

The automatic nozzle system shall be a wet pipe water mist system.

The nozzles shall be automatic nozzles.

Sidewall nozzles shall have the thermal release element within 100 mm to 300 mm below the ceiling and in accordance with the installation instructions.

4.2 Fire test categories

Fire tests are described in Clause 7.

Room testing with the following fire packages: A, B, C and D shall be carried out for all ceiling mounted nozzle systems.

Room testing with the following fire packages: F1, F2, F3 and G shall be carried out for all sidewall mounted nozzle systems.

Fire tests for open spaces (larger rooms) or taller rooms are optional and shall be carried out only if requested by the manufacturer.

The fire test that shall be carried out for each fire test series is shown in Table 1.

Table 1 — Fire test series

Fire test series	Fire tests for ceiling mounted nozzles	Fire tests for sidewall mounted nozzles	Test room ceiling height
Room ^a	A	F1	2,5 m and 3,5 m
	B, C, D	F2, F3, G	2,5 m or 3,5 m
Open Space ^b	E ^c	H ^c	2,5 m or 3,5 m
Taller rooms ^b	A, B, C, D, E ^c	F1, F2, F3, G, H ^c	max 5,5 m
^a Mandatory test series. ^b Optional test series. ^c Two tests.			

NOTE Some countries might have a national annex with guidance (additional requirements) on the test room ceiling height.

Table 2 — Description of fire tests for ceiling mounted nozzles

Item	Fire test	Clause
A	Corner test	7.1
B	Between two nozzles test	7.1
C	Beneath a nozzle test	7.1
D	Ventilation test	7.1
E	Open room test	7.1

Table 3 — Description of fire tests for sidewall mounted nozzles

Item	Fire test	Clause
F1, F2	Corner tests	7.2
F3	Between two nozzles test	7.2
G	Ventilation test	7.2
H	Open room test	7.2

5 Fuel packages

5.1 Ignition package

Ignition package, consisting of a square tray of internal dimensions 300 mm × 300 mm × 100 mm deep, made from 12 gauge steel containing 200 ml of commercial grade heptane floated on water of 25 mm minimum depth.

prEN 14972-17:2022 (E)

A wood crib consisting of 8 layers of wood sticks of *Pinus silvestris*, with 4 sticks per layer spaced 50 mm apart, shall be placed on top of the steel tray. An optional lip can be added to the steel tray to provide stability to the crib. The wood sticks shall be 38 mm × 38 mm cross-section by 305 mm long (actual) and plane finish. The complete wood crib shall have the nominal dimensions of 305 mm × 305 mm × 305 mm and shall weigh $(8\,250 \pm 250)$ g (see Figure 1 and Figure 2).

Two cotton wicks, each 250 mm long, soaked in 100 ml of heptane, of which 150 mm of each wick, shall be placed on a fire brick and laid along the edge of the foam sheets with the remaining 100 mm exposed.

5.2 Fuel package

Fuel package, consisting of 2 sheets of non-fire resisting polyether foam 775 mm × 865 mm × 75 mm, having a density of 20 kg/m³. Each sheet shall be glued to a sacrificial backing board, 775 mm × 865 mm × 12 mm, which is attached to a wooden supporting frame (see Figure 1 and Figure 2). The foam sheets shall be flush with the top and sides of the sacrificial board and frame.

5.3 Plywood panels

For the corner tests, two walls shall be covered, floor to ceiling, by 12 mm thick plywood panels covering $(2,4 \pm 0,1)$ m in length (see Figure 3, Figure 8 and Figure 9). The distance of the ignition and fuel package from the plywood panels walls shall be controlled to (50 ± 5) mm (see Figure 1).

For the centre tests, a partition arrangement of plywood panels shall be used, made from two 12 mm thick plywood panels each $(2,2 \pm 0,1)$ m in length and 1,2 m in height (see Figure 4, Figure 5 and Figure 10). The panels should be constructed so that there is no air gap between them.

The distance of the ignition and fuel package from the plywood partitions shall be controlled to (50 ± 5) mm (see Figure 2).

(standards.iteh.ai)

[oSIST prEN 14972-17:2022](https://standards.iteh.ai/catalog/standards/sist/61f8b420-1a06-4d9c-b6a4-20611ce0fbff/osist-pren-14972-17-2022)

<https://standards.iteh.ai/catalog/standards/sist/61f8b420-1a06-4d9c-b6a4-20611ce0fbff/osist-pren-14972-17-2022>

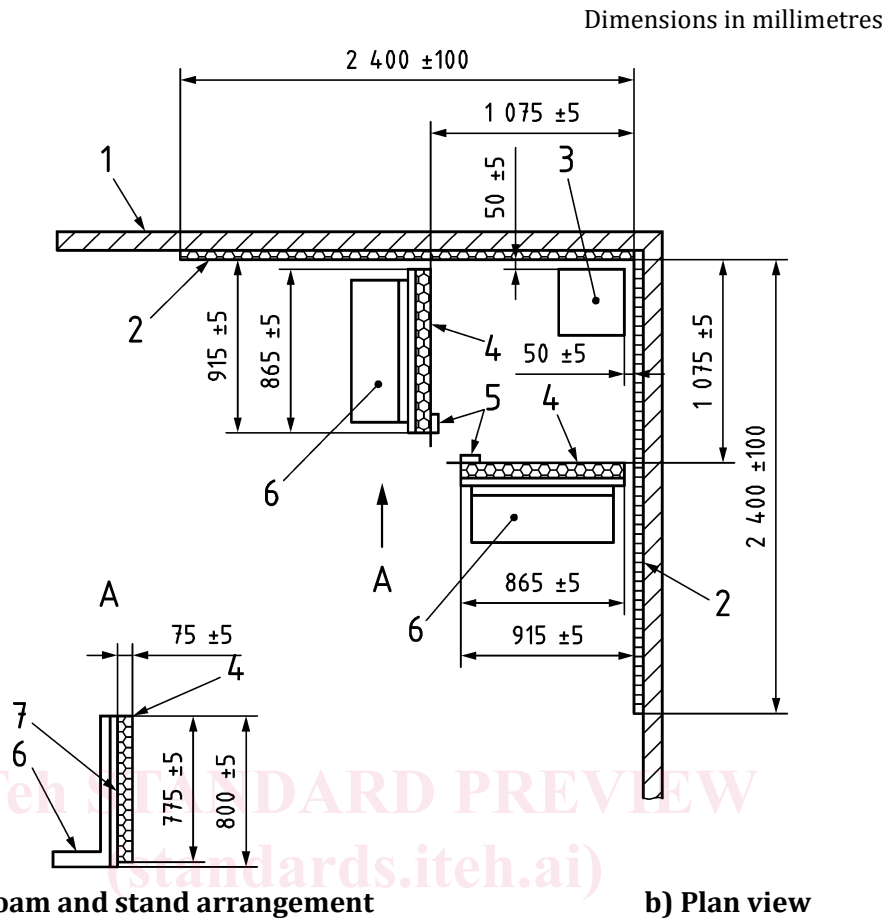
**Key**

- | | | | |
|---|--|---|-------------------------------------|
| 1 | wall of test room | 5 | fire brick supporting ignition wick |
| 2 | 12 mm thick plywood sheets | 6 | support stand |
| 3 | crib on tray containing heptane on water | 7 | sacrificial plywood board |
| 4 | foam sheet glued to sacrificial board | | |

Figure 1 — Corner fire test ignition and fuel package

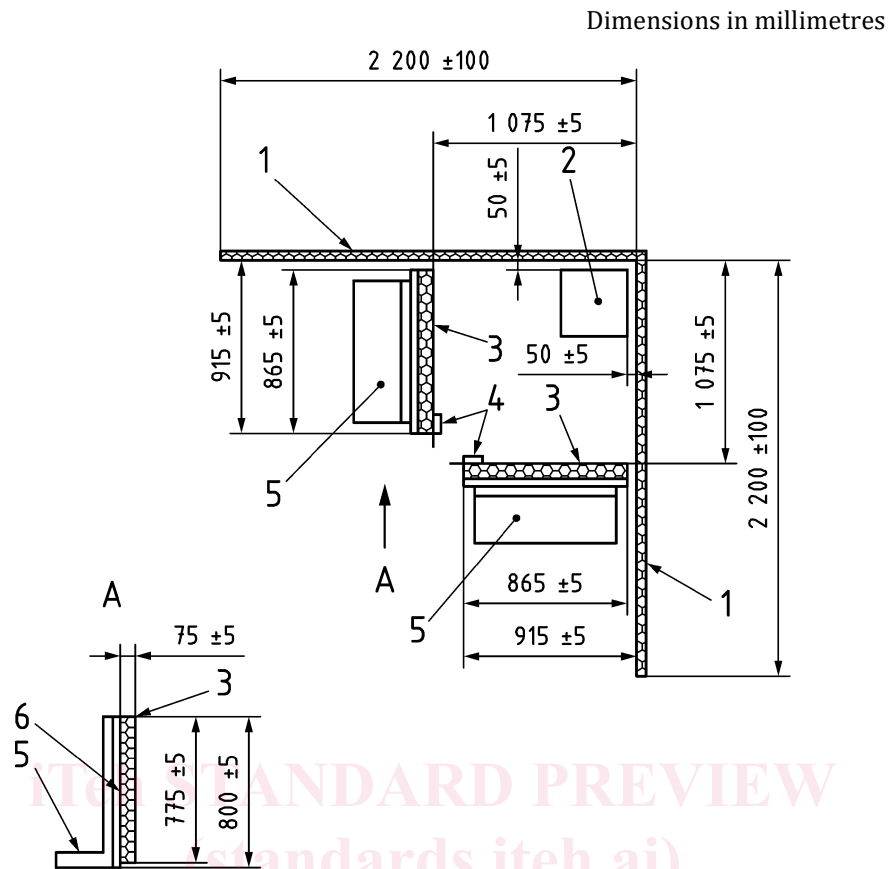

a) Side view of foam and stand arrangement

b) Plan view

Key

- | | | | |
|---|--|---|-------------------------------------|
| 1 | 12 mm thick plywood sheets | 4 | fire brick supporting ignition wick |
| 2 | crib on tray containing heptane on water | 5 | support stand |
| 3 | foam sheet glued to sacrificial board | 6 | sacrificial plywood board |

Figure 2 — Beneath a nozzle and between two nozzles fire test ignition and fuel package**6 Test arrangements**

6.1 For nozzle spacing's (S) between 2 m and 4 m, test room with the following internal dimensions:

- width (X): $(4,0 \pm 0,05)$ m;
- length (Y): $(8,0 \pm 0,05)$ m;
- ceiling height: $[(2,5 \text{ or } 3,5) \pm 0,05]$ m;
- doorway height: $(2,5 \pm 0,05)$ m.

6.2 For nozzle spacing's (S) between 4 m and 5 m, test room with the following internal dimensions:

X shall be greater than or equal to S up to the maximum of 5 m.

Y shall be equal to 2 times X .

- width (X): $[(4,0 \text{ to } 5,0) \pm 0,05]$ m;

- b) length (Y): $[(8,0 \text{ to } 10,0) \pm 0,05]$ m;
- c) ceiling height: $[(2,5 \text{ or } 3,5) \pm 0,05]$ m;
- d) doorway height: $(2,5 \pm 0,05)$ m.

The test room ceiling shall be covered by 12,5 mm Type F fire-rated plasterboard in accordance with EN 520:2009, Clause 4.

6.3 Nozzles of each temperature rating shall be tested once, for each of the fire tests selected in accordance with 4.2, with the fire loads shown in Figure 1 and Figure 2.

Install two or more nozzles of the same type in a test room.

For all arrangements, except open room, install another nozzle of the same type outside the test room near the open doorway, as shown in Figure 3 to Figure 6. This external nozzle shall be installed on an open length of vertical pipe work which is filled with a minimum of 70 ml of water. The nozzles shall be installed in accordance with the manufacturer's specification.

Figures show a two-nozzle arrangement but other nozzle spacing arrangements are permitted, providing the maximum nozzle spacing is applied from the corner of the room.

The plywood sheets, sacrificial boards, wooden frames, foam sheets and wood crib sticks shall be conditioned at a temperature of (23 ± 2) °C and a relative humidity of (50 ± 5) % for the conditioning periods recommended in EN 13238.

The crib shall be conditioned before the test, such that the moisture content is (10 ± 2) %, 3 mm below the wood stick surface.

Before the start of each test, the room temperature shall be $(20 \pm \frac{10}{5})$ °C. The room, wall panels, floor, fuel packages and contents shall be dry and the room relative humidity shall not be more than 70 %.

Fuel packages and ignition packages shall be placed in the test room as shown in the Figures in this document.

Tests shall be conducted with the minimum operating pressure and maximum spacing for the designated nozzle model type.

Thermocouples of type K up to 1,5 mm shall be installed in the test room.

Two thermocouples shall be installed at locations shown on the Figures in this document. These shall be at two heights; 1,6 m above the floor and 75 mm below the underside of the ceiling.

One thermocouple shall be installed adjacent to each nozzle and at the locations shown in the Figures in this document, at 75 mm below the underside of the ceiling.

Thermocouples shall be placed at a location away from the direct water spray from the nozzle in direction of the fuel package.

Two thermocouples shall be installed at locations shown in Figure 3, Figure 4, Figure 5, Figure 8, Figure 9 and Figure 10. These shall be at two heights; 1,6 m above the floor and 75 mm below the underside of the ceiling.

One thermocouple shall be installed adjacent to each nozzle and at the locations shown in the figures, at 75 mm below the underside of the ceiling.

NOTE The following drawings are indicative, mirror arrangements are acceptable.