**Paints and varnishes — Determination
of resistance to humidity —**

**Part 1:
Condensation (single-sided exposure)**

Peintures et vernis — Détermination de la résistance à l'humidité —

Partie 1: Condensation (exposition sur une seule face)

**iTeh STANDARD PREVIEW
(standards.iteh.ai)**

ISO 6270-1:2017

<https://standards.iteh.ai/catalog/standards/sist/8f0908aa-152c-4899-8f5f-b40bb9e0eb06/iso-6270-1-2017>



iTeh STANDARD PREVIEW
(standards.iteh.ai)

ISO 6270-1:2017

<https://standards.iteh.ai/catalog/standards/sist/8f0908aa-152c-4899-8f5f-b40bb9e0eb06/iso-6270-1-2017>



COPYRIGHT PROTECTED DOCUMENT

© ISO 2017, Published in Switzerland

All rights reserved. Unless otherwise specified, no part of this publication may be reproduced or utilized otherwise in any form or by any means, electronic or mechanical, including photocopying, or posting on the internet or an intranet, without prior written permission. Permission can be requested from either ISO at the address below or ISO's member body in the country of the requester.

ISO copyright office
Ch. de Blandonnet 8 • CP 401
CH-1214 Vernier, Geneva, Switzerland
Tel. +41 22 749 01 11
Fax +41 22 749 09 47
copyright@iso.org
www.iso.org

Contents

	Page
Foreword	iv
Introduction	v
1 Scope	1
2 Normative references	1
3 Terms and definitions	1
4 Limitations	1
5 Principle	2
6 Apparatus	2
7 Test specimen	4
8 Procedure	4
9 Evaluation	4
10 Precision	4
11 Test report	4
Bibliography	6

iTeh STANDARD PREVIEW (standards.iteh.ai)

[ISO 6270-1:2017](https://standards.iteh.ai/catalog/standards/sist/8f0908aa-152c-4899-8f5f-b40bb9e0eb06/iso-6270-1-2017)

<https://standards.iteh.ai/catalog/standards/sist/8f0908aa-152c-4899-8f5f-b40bb9e0eb06/iso-6270-1-2017>

Foreword

ISO (the International Organization for Standardization) is a worldwide federation of national standards bodies (ISO member bodies). The work of preparing International Standards is normally carried out through ISO technical committees. Each member body interested in a subject for which a technical committee has been established has the right to be represented on that committee. International organizations, governmental and non-governmental, in liaison with ISO, also take part in the work. ISO collaborates closely with the International Electrotechnical Commission (IEC) on all matters of electrotechnical standardization.

The procedures used to develop this document and those intended for its further maintenance are described in the ISO/IEC Directives, Part 1. In particular the different approval criteria needed for the different types of ISO documents should be noted. This document was drafted in accordance with the editorial rules of the ISO/IEC Directives, Part 2 (see www.iso.org/directives).

Attention is drawn to the possibility that some of the elements of this document may be the subject of patent rights. ISO shall not be held responsible for identifying any or all such patent rights. Details of any patent rights identified during the development of the document will be in the Introduction and/or on the ISO list of patent declarations received (see www.iso.org/patents).

Any trade name used in this document is information given for the convenience of users and does not constitute an endorsement.

For an explanation on the voluntary nature of standards, the meaning of ISO specific terms and expressions related to conformity assessment, as well as information about ISO's adherence to the World Trade Organization (WTO) principles in the Technical Barriers to Trade (TBT) see the following URL: www.iso.org/iso/foreword.html. (standards.iteh.ai)

This document was prepared by Technical Committee ISO/TC 35, *Paints and varnishes*, Subcommittee SC 9, *General test methods for paints and varnishes*. ISO 6270-1:2017

This second edition cancels and replaces the first edition (ISO 6270-1:1998), which has been technically revised.

The main changes compared to the previous edition are as follows:

- the title has been changed;
- the terms and definitions clause has been added;
- a limitations clause concerning the use of other than standard test conditions has been added;
- the preparation of test specimens from liquid paints has been deleted, so only the exposure of coated specimens is described;
- the normative requirement on evaluation in accordance with ISO 4628 has been deleted; information has been moved to the introduction, as it is in ISO 6270-2;
- the size of the test specimens has been changed;
- the requirement to use water of grade 3 purity in accordance with ISO 3696^[1] was deleted;
- a clause on installation of the apparatus has been added;
- the precision has been clarified;
- the normative references have been updated;
- the supplementary test conditions previously in [Clause 4](#) and Annex A have been integrated in the test report, as appropriate, or deleted.

A list of all the parts in the ISO 6270 series can be found on the ISO website.

Introduction

This document is intended to give consistent conditions and procedures for the conditioning of pre-prepared test specimens which are to be evaluated for defects, which may develop when they are subjected to humid ambient atmospheres such as constant condensation-water atmospheres or alternating condensation-water atmospheres.

The tests are designed to clarify the behaviour of the test specimens in humid ambient atmospheres, and to pinpoint any defects in the protection of the test specimens against corrosion. The testing of coatings in these atmospheres does not necessarily give lifetime prediction data.

After conditioning, the test specimens are evaluated either in accordance with agreed documents, such as the appropriate part(s) of ISO 4628^[2], or by procedures agreed between the interested parties.

iTeh STANDARD PREVIEW (standards.iteh.ai)

[ISO 6270-1:2017](https://standards.iteh.ai/catalog/standards/sist/8f0908aa-152c-4899-8f5f-b40bb9e0eb06/iso-6270-1-2017)

<https://standards.iteh.ai/catalog/standards/sist/8f0908aa-152c-4899-8f5f-b40bb9e0eb06/iso-6270-1-2017>

iTeh STANDARD PREVIEW
(standards.iteh.ai)

ISO 6270-1:2017

<https://standards.iteh.ai/catalog/standards/sist/8f0908aa-152c-4899-8f5f-b40bb9e0eb06/iso-6270-1-2017>

Paints and varnishes — Determination of resistance to humidity —

Part 1: Condensation (single-sided exposure)

1 Scope

This document specifies a method for determining the resistance of paint films, paint systems and related products to conditions of condensation in accordance with the requirements of coating or product specifications.

The method is applicable to coatings, both on porous substrates such as wood, plaster and plasterboard and on non-porous substrates such as metal. It provides an indication of the performance likely to be obtained under severe conditions of exposure where continuous condensation occurs on the surface.

The procedure can reveal failures of the coating (including blistering, staining, softening, wrinkling and embrittlement) and deterioration of the substrate.

NOTE The shape and preparation of the test specimens, the duration of the test and the assessment of the test results are not covered by this document.

2 Normative references

ISO 6270-1:2017

The following documents are referred to in the text in such a way that some or all of their content constitutes requirements of this document. For dated references, only the edition cited applies. For undated references, the latest edition of the referenced document (including any amendments) applies.

ISO 3270, *Paints and varnishes and their raw materials — Temperatures and humidities for conditioning and testing*

ISO 4618, *Paints and varnishes — Terms and definitions*

3 Terms and definitions

For the purposes of this document, the terms and definitions given in ISO 4618 apply.

ISO and IEC maintain terminological databases for use in standardization at the following addresses:

- IEC Electropedia: available at <http://www.electropedia.org/>
- ISO Online browsing platform: available at <http://www.iso.org/obp>

4 Limitations

Temperature and humidity are important parameters affecting test results. Deviations from the requirements specified can lead to results that are not comparable. However, the interested parties may agree upon alternative parameters and these parameters shall be reported.

5 Principle

A coated test specimen is exposed to continuous condensation, and the effects of the exposure are evaluated by criteria agreed in advance between the interested parties, these criteria usually being of a subjective nature.

6 Apparatus

6.1 Construction of the apparatus

6.1.1 The apparatus shall be constructed of chemically resistant materials, and consist essentially of an electrically heated water bath, designed so that the cover is formed by the blanking specimens (6.1.3) or test specimens, the upper faces of which are exposed to the environment (6.2.1), such that gaps are minimized and condensation forms on the inner face of the test specimens.

6.1.2 The top of the bath shall be designed so that the test specimens are held at the preferred angle of $(60 \pm 5)^\circ$ to the horizontal to permit drainage of condensed water, and shall be such that water draining from one specimen does not come into contact with another. In any case, the angle of the specimens to the horizontal shall be between 15° and 75° .

NOTE When revising ISO 6270:1980 to ISO 6270-1:1998, the angle of the specimens to the horizontal was changed from $(15 \pm 5)^\circ$ to $(60 \pm 5)^\circ$, and the temperature of the air below the specimens was maintained at $(38 \pm 2)^\circ\text{C}$ rather than at that of the water itself. Work has shown that the results do not differ substantially between the two sets of conditions.

6.1.3 Suitable inert blanking specimens shall be provided for use in setting up the apparatus if the number of test specimens is insufficient to form a complete cover.

6.2 Water bath

6.2.1 The sides of the water bath shall be suitably insulated to ensure that the temperature in the air space above the water, when measured approximately 25 mm below the test specimens, is maintained at a uniform temperature of $(38 \pm 2)^\circ\text{C}$ unless otherwise specified.

Temperatures of $(49 \pm 2)^\circ\text{C}$ and $(60 \pm 2)^\circ\text{C}$ are recommended if $(38 \pm 2)^\circ\text{C}$ is too low.

6.2.2 The water shall be maintained at a constant level by means of an automatic control device. If the device does not regulate the water level automatically, adjust the level of the water by regular addition of water.

The use of ordinary tap water may cause calcification of the apparatus, so follow the instrument manufacturer's instructions concerning the quality of the water used.

An example of a climatic chamber is shown in [Figure 1](#).

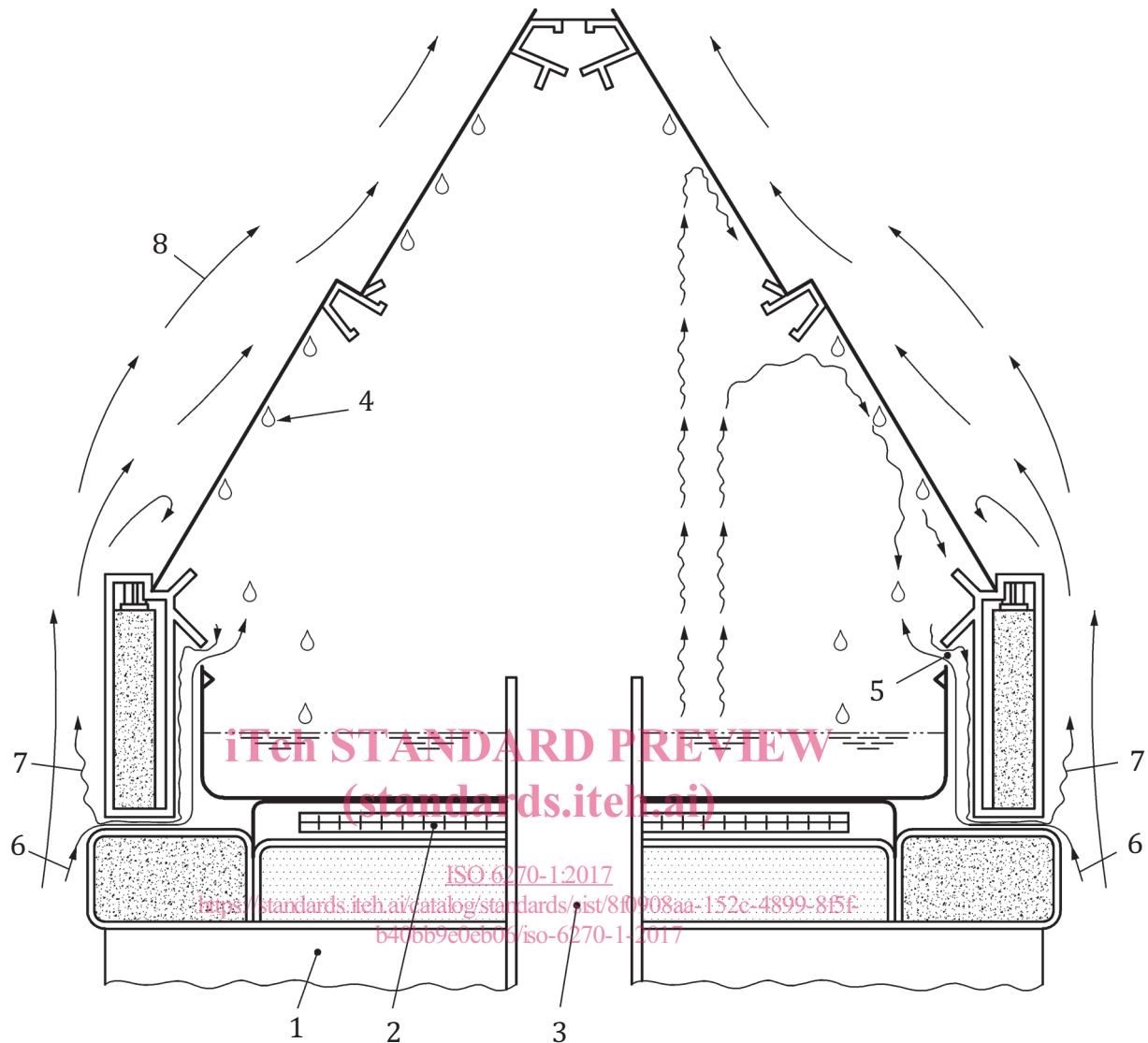
**Key**

- | | | | |
|---|--------------------------|---|----------------------------|
| 1 | base cabinet | 5 | moisture diffusion channel |
| 2 | heater | 6 | air in |
| 3 | dry off air duct | 7 | moisture out |
| 4 | condensation on specimen | 8 | convection currents |

Figure 1 — Example of a climatic chamber**6.3 Installation of the apparatus**

The apparatus shall be installed in a room with an ambient atmosphere containing no corrosive constituents (e.g. it shall not be installed in a chemical laboratory), at a room temperature of $(23 \pm 5) ^\circ\text{C}$ and at a relative atmospheric humidity of 75 % max., in such a way that it is protected against draughts and solar radiation. In the case of comparison tests, the ambient temperature in the installation room shall be the standard temperature of $(23 \pm 2) ^\circ\text{C}$ in accordance with ISO 3270.