**Paints and varnishes — Determination
of stone-chip resistance of coatings —
Part 2:
Single-impact test with a guided
impact body**

iTeh STANDARD PREVIEW
(standards.iteh.ai)
*Peintures et vernis — Détermination de la résistance des revêtements
aux impacts de cailloux —
Partie 2: Essai de choc simple par corps percutant guidé*

[ISO 20567-2:2017](https://standards.iteh.ai/catalog/standards/sist/1a4faff6-a2e0-4540-8f02-587edb1900ba/iso-20567-2-2017)

<https://standards.iteh.ai/catalog/standards/sist/1a4faff6-a2e0-4540-8f02-587edb1900ba/iso-20567-2-2017>



iTeh STANDARD PREVIEW
(standards.iteh.ai)

ISO 20567-2:2017

<https://standards.iteh.ai/catalog/standards/sist/1a4faff6-a2e0-4540-8f02-587edb1900ba/iso-20567-2-2017>



COPYRIGHT PROTECTED DOCUMENT

© ISO 2017, Published in Switzerland

All rights reserved. Unless otherwise specified, no part of this publication may be reproduced or utilized otherwise in any form or by any means, electronic or mechanical, including photocopying, or posting on the internet or an intranet, without prior written permission. Permission can be requested from either ISO at the address below or ISO's member body in the country of the requester.

ISO copyright office
Ch. de Blandonnet 8 • CP 401
CH-1214 Vernier, Geneva, Switzerland
Tel. +41 22 749 01 11
Fax +41 22 749 09 47
copyright@iso.org
www.iso.org

Contents

	Page
Foreword.....	iv
Introduction.....	v
1 Scope	1
2 Normative references	1
3 Terms and definitions	1
4 Principle	1
5 Apparatus and materials	2
6 Test panels	2
6.1 Substrate.....	2
6.2 Preparation and coating.....	2
6.3 Thickness of the coating.....	2
7 Procedure	4
7.1 Calibration.....	4
7.2 Conditioning of the test panels.....	4
7.3 Test conditions.....	4
7.4 Number of test runs.....	4
7.5 Determination.....	5
8 Evaluation	5
9 Precision	6
9.1 Repeatability limit, r	6
9.2 Reproducibility limit, R	6
10 Test report	7
Annex A (informative) Examples of suitable procedures for removing loose paint	8
Annex B (normative) Calibration of the test apparatus	9

Foreword

ISO (the International Organization for Standardization) is a worldwide federation of national standards bodies (ISO member bodies). The work of preparing International Standards is normally carried out through ISO technical committees. Each member body interested in a subject for which a technical committee has been established has the right to be represented on that committee. International organizations, governmental and non-governmental, in liaison with ISO, also take part in the work. ISO collaborates closely with the International Electrotechnical Commission (IEC) on all matters of electrotechnical standardization.

The procedures used to develop this document and those intended for its further maintenance are described in the ISO/IEC Directives, Part 1. In particular the different approval criteria needed for the different types of ISO documents should be noted. This document was drafted in accordance with the editorial rules of the ISO/IEC Directives, Part 2 (see www.iso.org/directives).

Attention is drawn to the possibility that some of the elements of this document may be the subject of patent rights. ISO shall not be held responsible for identifying any or all such patent rights. Details of any patent rights identified during the development of the document will be in the Introduction and/or on the ISO list of patent declarations received (see www.iso.org/patents).

Any trade name used in this document is information given for the convenience of users and does not constitute an endorsement.

For an explanation on the meaning of ISO specific terms and expressions related to conformity assessment, as well as information about ISO's adherence to the World Trade Organization (WTO) principles in the Technical Barriers to Trade (TBT) see the following URL: www.iso.org/iso/foreword.html.

The committee responsible for this document is ISO/TC 35, *Paints and varnishes*, Subcommittee SC 9, *General test methods for paints and varnishes*.

This second edition cancels and replaces the first edition (ISO 20567-2:2005), which has been technically revised with the following main changes: www.iso.org/iso/20567-2:2017

- a specification has been added, when the calibration of the apparatus shall be made;
- reference to optical imaging has been deleted;
- the clause on sampling has been deleted;
- the description of suitable methods for removal of loose paint have been transferred to an informative annex as examples, and, for the method using adhesive tape, the adhesive strength of the tape is no longer specified;
- some minor corrections have been made;
- this document is revised editorially and the normative references have been updated.

A list of all parts in the ISO 20567 series can be found on the ISO website.

Introduction

In the automobile industry, multi-layer paint coatings are applied to car bodies for protection. Grit, road-metal and other materials can damage these coatings in such a way that individual layers come off or the whole coating delaminates from the substrate.

Stone chipping can be simulated by means of single- and/or multi-impact tests. ISO 20567-1 describes multi-impact testing; ISO 20567-2 and ISO 20567-3 describe single-impact tests.

iTeh STANDARD PREVIEW (standards.iteh.ai)

[ISO 20567-2:2017](https://standards.iteh.ai/catalog/standards/sist/1a4faff6-a2e0-4540-8f02-587edb1900ba/iso-20567-2-2017)

<https://standards.iteh.ai/catalog/standards/sist/1a4faff6-a2e0-4540-8f02-587edb1900ba/iso-20567-2-2017>

iTeh STANDARD PREVIEW
(standards.iteh.ai)

ISO 20567-2:2017

<https://standards.iteh.ai/catalog/standards/sist/1a4faff6-a2e0-4540-8f02-587edb1900ba/iso-20567-2-2017>

Paints and varnishes — Determination of stone-chip resistance of coatings —

Part 2: Single-impact test with a guided impact body

1 Scope

This document specifies a method for the evaluation of the resistance of automobile finishes and other coatings to the impact of a wedge-shaped body projected onto the surface under test to simulate the impact of stones.

2 Normative references

The following documents are referred to in the text in such a way that some or all of their content constitutes requirements of this document. For dated references, only the edition cited applies. For undated references, the latest edition of the referenced document (including any amendments) applies.

ISO 1514, *Paints and varnishes — Standard panels for testing*

ISO 2808, *Paints and varnishes — Determination of film thickness*

ISO 3270, *Paints and varnishes and their raw materials — Temperatures and humidities for conditioning and testing*

EN 573-3, *Aluminium and aluminium alloys — Chemical composition and form of wrought products — Part 3: Chemical composition and form of products*

3 Terms and definitions

No terms and definitions are listed in this document.

ISO and IEC maintain terminological databases for use in standardization at the following addresses:

- IEC Electropedia: available at <http://www.electropedia.org/>
- ISO Online browsing platform: available at <http://www.iso.org/obp>

4 Principle

The stone-chip resistance of the coating under test is checked by projecting a defined impact body onto it. The impact body used in the test has a wedge-shaped cutting edge to obtain a damage pattern equivalent to that produced in a multi-impact test. The wedge-shaped impact body is pushed onto the coating under test by the transmission of a pulse of energy from a steel ball accelerated using compressed air.

Loose fragments of coating material are removed.

The stone-chip resistance is evaluated by measuring the total width of the delaminated coating, including the mark left by the wedge.

5 Apparatus and materials

Ordinary laboratory apparatus, together with the following.

5.1 Single-impact tester.

[Figure 1](#) shows the upper part of the test apparatus.

[Figure 2](#) shows the shape of the impact body and its dimensions. The impact body shall be made of hardened steel (hardness 60 HRC to 66 HRC).

The test panel is inserted on the tester with the wedge-shaped end of the impact body touching the coated test panel and the spring exerting a slight pressure on the body. A steel ball of mass inferior to that of the impact body is accelerated by a compressed-air blast ($p = 300$ kPa) and transmits part of its energy to the impact body, which then strikes the test panel.

NOTE 100 kPa = 1bar.

The impact body shall be checked, and replaced if necessary, after a maximum of 500 test runs (i.e. after 500 impacts) or at the end of the series of tests during which the impact body passes the point at which it has been used for a total of 500 test runs.

6 Test panels

6.1 Substrate

Use test panels of at least 100 mm × 100 mm in size that are at least 0,7 mm thick.

6.2 Preparation and coating

Prepare each test panel in accordance with ISO 1514 before coating and drying or stoving it. Use the application method specified by the paint manufacturer.

6.3 Thickness of the coating

Determine the thickness, in micrometres, of the dry coating by one of the procedures specified in ISO 2808.

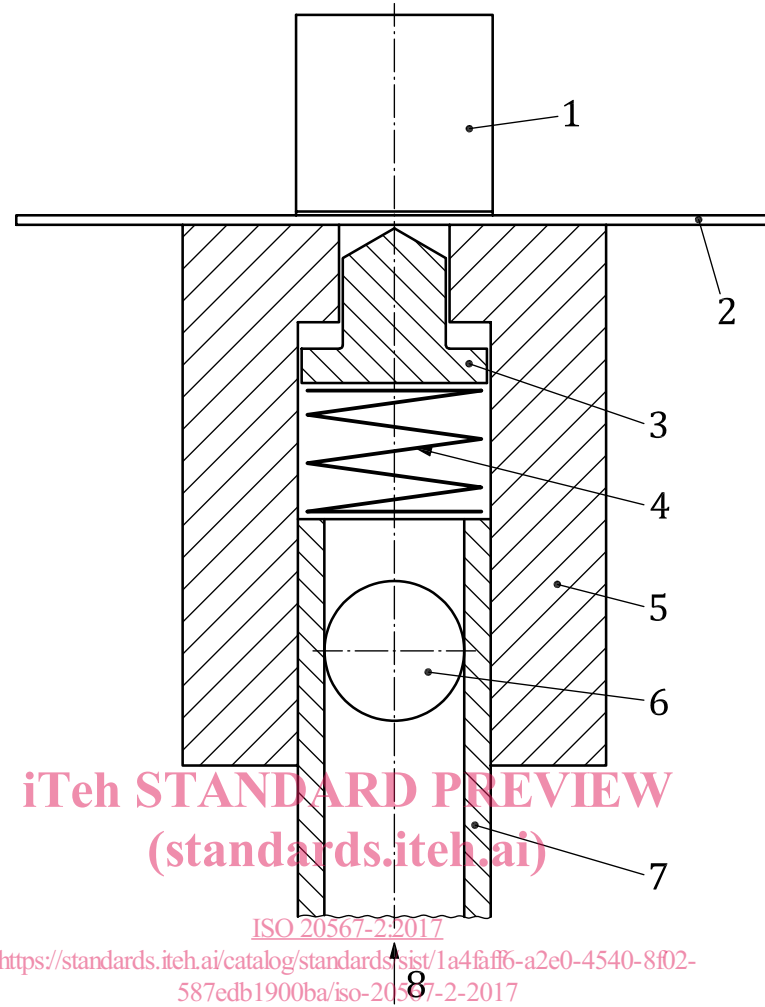

Key

- | | | | |
|---|---|---|---------------------------------------|
| 1 | counterweight (mass exceeding 1 kg) | 5 | housing |
| 2 | test panel | 6 | steel ball, hardness 60 HRC to 66 HRC |
| 3 | impact body | 7 | pipe, bore $8,6_0^{0,015}$ mm |
| 4 | steel spring, diameter of wire 0,8 mm, 2,5 windings | 8 | compressed air |

Figure 1 — Upper part of the test apparatus showing position of impact body