



Standard Test Method for Apparent Hoop Tensile Strength of Plastic or Reinforced Plastic Pipe by Split Disk Method¹

This standard is issued under the fixed designation D2290; the number immediately following the designation indicates the year of original adoption or, in the case of revision, the year of last revision. A number in parentheses indicates the year of last reapproval. A superscript epsilon (ϵ) indicates an editorial change since the last revision or reapproval.

This standard has been approved for use by agencies of the Department of Defense.

1. Scope

1.1 This test method covers the determination of the comparative apparent tensile strength of most plastic products utilizing a split disk test fixture, when tested under defined conditions of pretreatment, temperature, humidity, and test machine speed. This test method is applicable to reinforced-thermosetting resin pipe regardless of fabrication method. This test method also is applicable to extruded and molded thermo-plastic pipe.

Procedure A is used for reinforced-thermosetting resin pipe; Procedure B is used for thermoplastic pipe of any size; Procedure C is used for thermoplastic pipe with nominal diameter of 4½ in. and greater.

1.2 The values stated in inch-pound units are to be regarded as standard. The values given in parentheses are mathematical conversions to SI units that are provided for information only and are not considered standard.

1.3 *This standard does not purport to address all of the safety concerns, if any, associated with its use. It is the responsibility of the user of this standard to establish appropriate safety and health practices and determine the applicability of regulatory limitations prior to use.*

2. Referenced Documents

2.1 ASTM Standards:²

- D618 Practice for Conditioning Plastics for Testing
- D1599 Test Method for Resistance to Short-Time Hydraulic Pressure of Plastic Pipe, Tubing, and Fittings
- E4 Practices for Force Verification of Testing Machines

¹ This test method is under the jurisdiction of ASTM Committee F17 on Plastic Piping Systems and is the direct responsibility of Subcommittee F17.40 on Test Methods.

Current edition approved Nov. 1, 2008. Published November 2008. Originally approved in 1964. Last previous edition approved in 2004 as D2290–04. DOI: 10.1520/D2290-08.

² For referenced ASTM standards, visit the ASTM website, www.astm.org, or contact ASTM Customer Service at service@astm.org. For *Annual Book of ASTM Standards* volume information, refer to the standard's Document Summary page on the ASTM website.

3. Summary of Test Method

3.1 The test specimen is loaded through the suggested self-aligning split disk test fixture (Fig. 1) which applies tensile stress to the test ring. An apparent tensile strength rather than a true tensile strength is obtained in this test because of a bending moment imposed during test at the split between the split disk test fixture. This moment is induced by the change in contour of the ring between the two disk sections as they separate. The test fixture is designed to minimize the effect of this bending moment.

4. Significance and Use

4.1 Split disk tension tests, properly interpreted, provide reasonably accurate information with regard to the apparent tensile strength of plastic pipe when employed under conditions approximating those under which the tests are made.

4.2 Tension tests may provide data for research and development, engineering design, quality control, acceptance or rejection under specifications, and for special purposes. The test cannot be considered significant for applications differing widely from the load-time scale of the standard test.

NOTE 1—Procedure C has been used on polyethylene and polybutylene pipe to produce results equivalent to Quick Burst results (Test Method D1599) for 4 in. to 8 in. pipes.

5. Apparatus

5.1 *Micrometers*—Suitable ball-type micrometers, reading to at least 0.001 in., for measuring the width and thickness of the test specimens.

5.2 *Testing Machine*—A universal testing machine of the constant-rate-of-cross-head-movement type and comprising essentially the following:

5.2.1 *Drive Mechanism*—A drive mechanism for imparting to the crosshead a uniform controlled velocity with respect to the base, this velocity to be regulated as specified in Section 9.

5.2.2 *Load Indicator*—A load-indicating mechanism capable of showing the total tensile load carried by the test specimen. This mechanism shall be essentially free from inertia lag at the specified rate of testing and shall indicate the

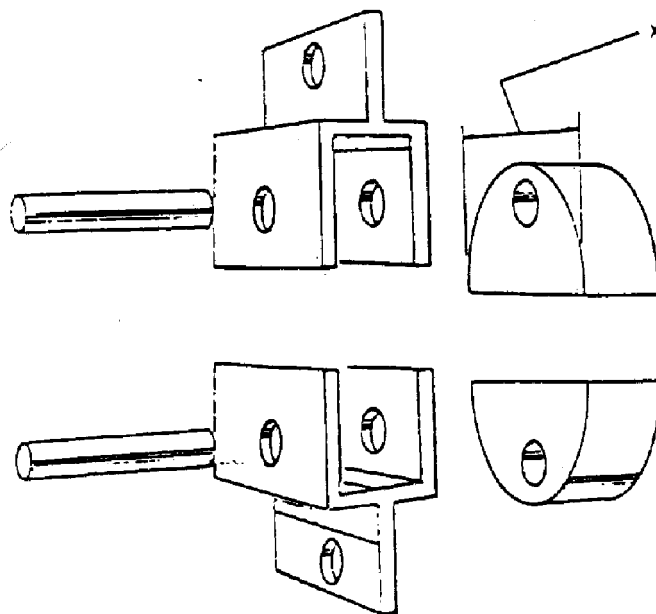

FIG. 1 Test Fixture: Typical

load with an accuracy of $\pm 1\%$ of the indicated value. The accuracy of the testing machine shall be verified in accordance with Method E4.

5.3 *Test Fixture*—The recommended test fixture is shown in Fig. 1. The width of the split disk for Procedure A and Procedure B shall be at least 0.1 in. greater than the width of the specimen. The width of the split disk for Procedure C shall be 2.0 in. \pm 0.1 in. The supports for holding the tension test fixture shall be self-aligning, that is, they shall be attached to the fixed and movable member of the test machine, respectively, in such a manner that they move freely into alignment as soon as any load is applied, so that the direction of the applied pull is directly perpendicular to the split axis of the test fixture.

5.4 *Conditioning Apparatus*—Apparatus for maintaining the standard laboratory atmospheric temperature of $23 \pm 2^\circ\text{C}$ ($73.4 \pm 3.6^\circ\text{F}$) and $50 \pm 5\%$ relative humidity for conditioning prior to test, as defined in Procedure A of Methods D618, shall be used, except 24 h will be the minimum time period.

6. Test Specimen

6.1 Test specimen for Procedure A shall be full-diameter, full-wall thickness rings cut from reinforced thermosetting resin pipe by any suitable means. Specimens shall conform to Fig. 2. Specimens shall have a minimum overall width of 0.90 in., and a minimum width in the reduced section(s) of 0.55 in. The number of reduced areas shall be one or two. If two, they must be located 180° apart. Reduced areas must be centered relative to the specimen width to within 0.05 in.

6.2 Test specimens for Procedure B shall be full-diameter, full-thickness rings cut from thermoplastic pipe, by any suitable means, as shown in Fig. 3. The minimum width of the ring, W , per Fig. 3 shall be 0.50-in. The maximum width of the ring shall be 2.00-in. Reduced areas shall be machined as

shown in Fig. 3 and shall be located at the point of minimum wall thickness and at 180° thereto except when the test is used for specialized purposes (see Note 2). The reduced areas of the specimen must be free of machining marks and uniform in cross section.

NOTE 2—The reduced sections for the extruded or molded specimens can be located at any points on the periphery of the specimen provided they are 180° apart, that is, even at the weld or “knot” line of the specimen if the strength of these areas is being investigated.

NOTE 3—Specimen ring width, W , per Fig. 3 may be varied between 0.50 in. and 2.00 in. For larger diameter pipes with greater wall thickness, specimen stability during testing is improved when ring width is greater.

6.3 Test specimens for Procedure C shall be cut normal to the pipe axis with parallel sides. The width of the specimen shall be nominally 1.75 in. to 2.00 in. Two areas, one of which includes the minimum pipe wall thickness and the other 180° opposite, shall be wet sanded to remove cutting marks; care must be exercised to retain the rectangular cross-section of the prepared areas.

6.4 *Number of Test Specimens*—The number of test specimens is optional; however, a minimum of five specimens is needed to obtain a reliable average for a sample. For quality control purposes, the sample quantity shall be one, and in cases of disagreement, five specimens shall be tested and the average value shall be recorded.

7. Conditioning

7.1 *Conditioning*—Condition the test specimens at $73.4 \pm 3.6^\circ\text{F}$ ($23 \pm 2^\circ\text{C}$) and $50 \pm 5\%$ relative humidity for not less than 24 h prior to test in accordance with Procedure A of Methods D618 for those tests where conditioning is required. In cases of disagreement, the tolerances shall be $\pm 1.8^\circ\text{F}$ ($\pm 1^\circ\text{C}$) and $\pm 2\%$ relative humidity.

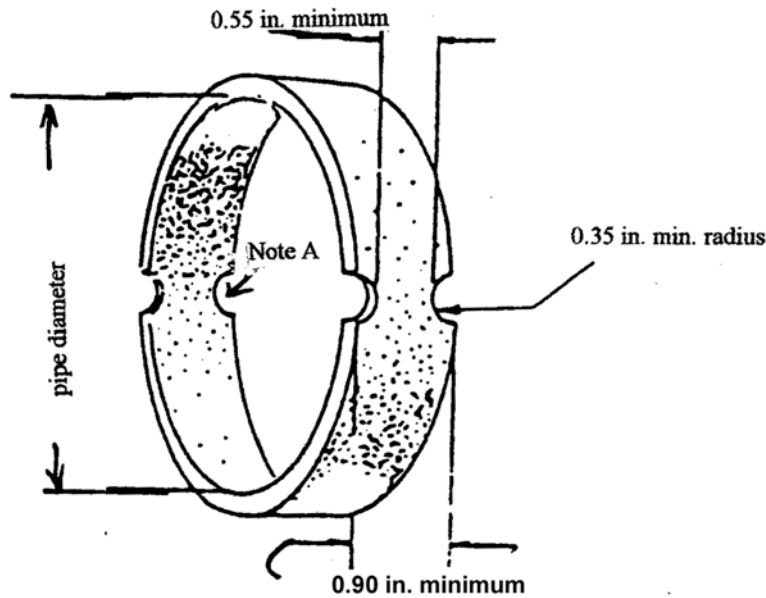

a) Second reduced area is optional.

FIG. 2 Reduced-Section Specimens for Procedure A

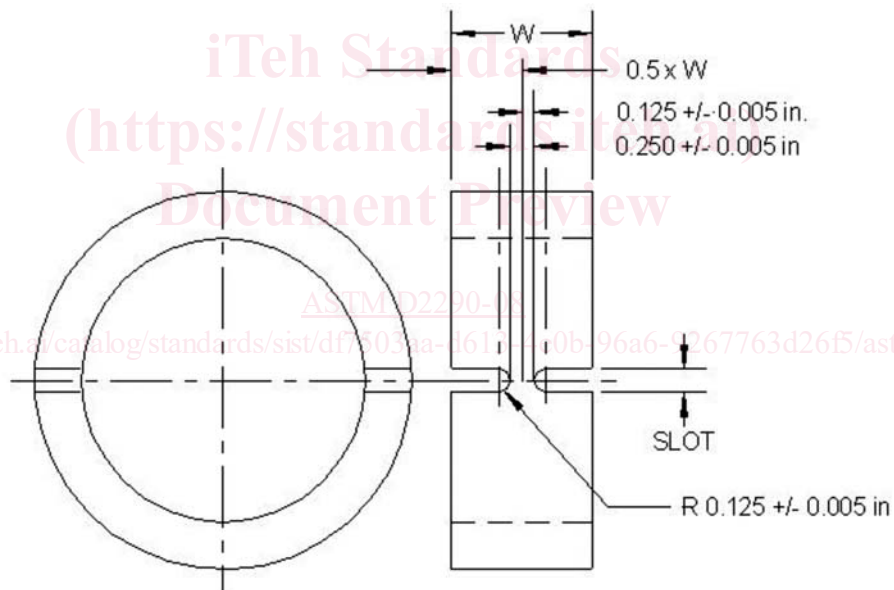

FIG. 3 Reduced Section Specimen for Procedure B

7.2 *Test Conditions*—Conduct tests in the standard laboratory atmosphere of $73.4 \pm 3.6^\circ\text{F}$ ($23 \pm 2^\circ\text{C}$) and $50 \pm 5\%$ relative humidity, unless otherwise specified in the test methods or in this specification. In cases of disagreement, the tolerances shall be $\pm 1.8^\circ\text{F}$ ($\pm 1^\circ\text{C}$) and $\pm 2\%$ relative humidity.

7.3 Special conditioning procedures may be used by agreement between cooperating laboratories.

8. Speed of Testing

8.1 Speed of testing is velocity of separation of the two members of the testing machine when running idle (under no

load). Speed of testing shall be 0.1 in./min (ipm) minimum and 0.5 ipm maximum for Procedure A. It shall be 0.5 ipm for Procedures B and C.

9. Procedure

9.1 *Procedure A* (parallel-fiber-reinforced specimens):

9.1.1 Measure the minimum width of the reduced area(s) to the nearest 0.001 in., using a suitable micrometer.

9.1.2 Mount the specimen on the lubricated periphery of the test fixture, with the reduced area(s) centered 2.0 ± 0.2 in. away from the split in the disk.